

**IN THE SUPREME COURT OF INDIA
ORIGINAL JURISDICTION
CIVIL WRIT PETITION (PIL) No. 324 OF 2020
(PUBLIC INTEREST LITIGATION)**

IN THE MATTER OF:

DR. BALRAM SINGH

...PETITIONER

VS

UNION OF INDIA & ORS.

...RESPONDENTS

**STATUS REPORT ON BEHALF OF THE UNION OF
INDIA IN COMPLIANCE OF HON'BLE SUPREME
COURT ORDER DATED 20.10.2023**

PAPER BOOK

(FOR INDEX PLEASE SEE INSIDE)

ADVOCATE FOR THE RESPONDENT: Mr. Amrish Kumar

INDEX

Sl No.	Particulars	Pages
1	Status Report on behalf of the Uuiou of India in compliance of Hon'ble Supreme Court order dated 20.10.2023.	1-21
2	<u>Annexure -I</u> A copy of D.O. letter dated 17.11.2023 to MoHUA	22
3	<u>Annexure -II</u> A true copy of OM dated 16.01.2024 issued by MoHUA	23-24
4.	<u>Annexure -III</u> A copy of letter dated 14.11.2023 to Chief Secretaries of all States/UTs.	25-26
5	<u>Annexure -IV (A to X)</u> Action Taken Report from States/UTs.	27-511
6.	<u>Annexure -V</u> A copy of OM dated 29.12.2023 issued by Railway Board.	512
7.	<u>Annexure -VI</u> A true copy of Letter dated 04.01.2024 issued by Directorate General, Defence Estates.	513
8.	<u>Annexure-VII</u> A true copy of Letter dated 09.01.2024 issued by MoSJE to NSKFDC.	514
9	<u>Annexure-VII-A</u> A true copy of Letter dated 09.01.2024 issued by MoSJE to States/UTs.	515-521
10	<u>Annexure-VIII</u> A copy of Letter dated 22.12.2023 to NALSA	522-523

11	<u>Annexure-IX</u> A Copy of the Training Manual for Survey of Manual Scavengers.	524-571
12	<u>Annexure-X</u> A copy of letter dated 18.01.2024 to all States/UTs for providing scholarship.	572
13	<u>Annexure-XI</u> A copy of Letter dated 16.01.2024, National Commission for Safai Karamcharis regarding Status of Vigilance Committees and State Level Monitoring Committees in the States/UTs.	573-579

IN THE HON'BLE SUPREME COURT OF INDIA

WRIT PETITION (C) NO. 324 OF 2020

IN THE MATTER OF:

DR. BALRAM SINGH

...PETITIONER

VERSUS

UNION OF INDIA & ORS.

...RESPONDENT(S)

STATUS REPORT ON BEHALF OF UNION OF INDIA IN
COMPLIANCE OF HON'BLE COURT ORDER DATED
20.10.2023

1. It is submitted that Hon'ble Supreme Court vide order dated 20.10.2023 passed directions in the WP (C) No. 324/2020 filed by Dr. Balram Singh. The directions passed by the Hon'ble Supreme Court are reproduced hereunder:

1.1. "The Union should take appropriate measures and frame policies, and issue directions, to all statutory bodies, including corporations, railways, cantonments, as well as agencies under its control, to ensure that manual sewer cleaning is completely eradicated in a phased manner, and also issue such guidelines and directions as are essential, that any sewer cleaning work outsourced, or required to be discharged, by or through contractors or agencies, do

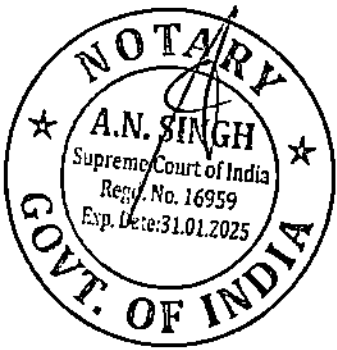

ए.बी. प्रसाद / S. B. PRASAD
असल सचिव / Under Secretary
सामाजिक न्याय एवं अधिकारिता विभाग
Department of Social Justice and Empowerment
सामाजिक न्याय एवं अधिकारिता मंत्रालय
Ministry of Social Justice and Empowerment
भारत सरकार, संसदीय कम्प्लेक्स, नई दिल्ली
Government of India, CSD Complex, New Delhi

not require individuals to enter sewers, for any purpose whatsoever."

- 1.2. All States and Union Territories are likewise, directed to ensure that all departments, agencies, corporations and other agencies (by whatever name called) ensure that guidelines and directions framed by the Union are embodied in their own guidelines and directions; the states are specifically directed to ensure that such directions are applicable to all municipalities, and local bodies functioning within their territories;
- 1.3. The Union, State and Union Territories are directed to ensure that full rehabilitation (including employment to the next of kin, education to the wards, and skill training) measures are taken in respect of sewage workers, and those who die;
- 1.4. The court hereby directs the Union and the States to ensure that the compensation for sewer deaths is increased (given that the previous amount fixed, i.e., ₹ 10 lakhs) was made applicable from 1993. The current equivalent of that amount is Rs. 30 lakhs. This shall be the amount to be paid, by the concerned agency, i.e., the Union, the Union Territory or the State as the case may be. In other words, compensation for sewer deaths shall be ₹ 30 lakhs. In the event, dependents of any victim have not been paid such amount, the above amount shall be payable to them. Furthermore, this shall be the amount to be hereafter paid, as compensation.

श्री. बी. प्रसाद / S. B. PRASAD
अवर सचिव / Under Secretary
सामाजिक न्याय एवं अधिकारिता विभाग
Department of Social Justice and Empowerment
सामाजिक न्याय एवं अधिकारिता विभाग
Ministry of Social Justice and Empowerment
एन.ए. कॉम्प्लेक्स, नई दिल्ली
Government of India, CGO Complex, New Delhi

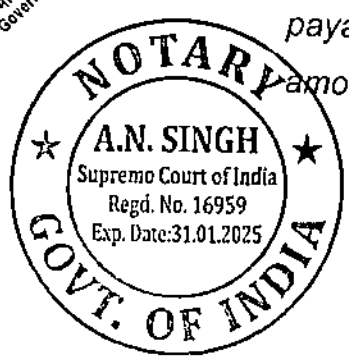

श्री. बी. प्रसाद / S. B. PRASAD
अवर सचिव / Under Secretary
सामाजिक न्याय एवं अधिकारिता विभाग
Department of Social Justice and Empowerment
सामाजिक न्याय एवं अधिकारिता विभाग
Ministry of Social Justice and Empowerment
एन.ए. कॉम्प्लेक्स, नई दिल्ली
Government of India, CGO Complex, New Delhi

1.5. Likewise, in the case of sewer victims suffering disabilities, depending upon the severity of disabilities, compensation shall be disbursed. However, the minimum compensation shall not be less than ₹ 10 lakhs. If the disability is permanent, and renders the victim economically helpless, the compensation shall not be less than ₹ 20 lakhs.

1.6. The appropriate government (i.e., the Union, State or Union Territories) shall devise a suitable mechanism to ensure accountability, especially wherever sewer deaths occur in the course of contractual or "outsourced" work. This accountability shall be in the form of cancellation of contract, forthwith, and imposition of monetary liability, aimed at deterring the practice.

1.7. The Union shall devise a model contract, to be used wherever contracts are to be awarded, by it or its agencies and corporations, in the concerned enactment, such as the Contract Labour (Prohibition and Regulation Act), 1970, or any other law, which mandates the standards – in conformity with the 2013 Act, and rules, are strictly followed, and in the event of any mishap, the agency would lose its contract, and possibly blacklisting. This model shall also be used by all States and Union Territories.

1.8. The NCSK, NCSC, NCST and the Secretary, Union Ministry of Social Justice and Empowerment, shall, within 3 months from today, draw modalities for the conduct of a National Survey. The survey shall be

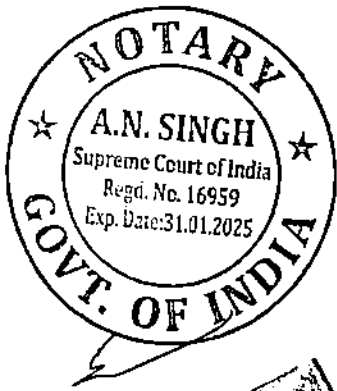

एस. बी. प्रसाद / S. B. PRASAD
अवर सचिव / Under Secretary
सामाजिक न्याय एवं अधिकारिता विभाग
Department of Social Justice and Empowerment
सामाजिक न्याय एवं अधिकारिता मंत्रालय
Ministry of Social Justice and Empowerment
भारत सरकार, सीजीओ कॉम्प्लेक्स, नई दिल्ली
Government of India, CGO Complex, New Delhi

ideally conducted and completed in the next one year.

1.9. To ensure that the survey does not suffer the same fate as the previous ones, appropriate models shall be prepared to educate and train all concerned committees.

1.10. The Union, State and Union Territories are hereby required to set up scholarships to ensure that the dependents of sewer victims, (who have died, or might have suffered disabilities) are given meaningful education.

1.11. The National Legal Services Authority (NALSA) shall also be part of the consultations, toward framing the aforesaid policies. It shall also be involved, in co-ordination with state and district legal services committees, for the planning and implementation of the survey. Furthermore, the NALSA shall frame appropriate models (in the light of its experience in relation to other models for disbursement of compensation to victims of crime) for easy disbursement of compensation.

1.12. The Union, State and Union Territories are hereby directed to ensure co-ordination with all the commissions (NCSK, NCSC, NCST) for setting up of state level, district level committees and commissions in a time bound manner. Furthermore, constant monitoring of the existence of vacancies and their filling up shall take place.

1.13. "NCSK, NCSC, NCST and the Union

एस्. बी. प्रसाद / S. B. PRASAD
अवर सचिव / Under Secretary
सामाजिक न्याय एवं अधिकारिता विभाग
Department of Social Justice and Empowerment
सामाजिक न्याय एवं अधिकारिता मंत्रालय
Ministry of Social Justice and Empowerment
भारत सरकार, केंद्रीय कार्यालय, नई दिल्ली
Government of India, CGO Complex, New Delhi

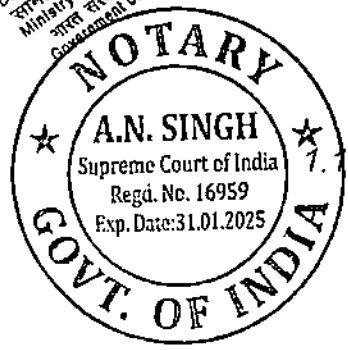

government are required to co- ordinate and prepare training and education modules, for information and use by district and state level agencies, under the 2013 Act.”

1.14. A portal and a dashboard, containing all relevant information, including the information relating to sewer deaths, and victims, and the status of compensation disbursement, as well as rehabilitation measures taken, and existing and available rehabilitation policies shall be developed and launched at an early date.

2. It is submitted that the Respondent Union has complied with the directions and action taken report thereof is being submitted by way of present status report.

3. This Hon'ble Court at para 96(1) directed, "The Union should take appropriate measures and frame policies, and issue directions, to all statutory bodies, including corporations, railways, cantonments, as well as agencies under its control, to ensure that manual sewer cleaning is completely eradicated in a phased manner, and also issue such guidelines and directions as are essential, that any sewer cleaning work outsourced, or required to be discharged, by or through contractors or agencies, do not require individuals to enter sewers, for any purpose whatsoever."

3.1. In pursuance of the above quoted direction, following steps have been taken by the Union of India through Ministry of Social Justice and Empowerment (MoSJE)

एस. बी. प्रसाद / S. B. PRASAD
अवर सचिव / Under Secretary
सामाजिक न्याय एवं अधिकारिता विभाग
Department of Social Justice and Empowerment
सामाजिक न्याय एवं अधिकारिता मंत्रालय
Ministry of Social Justice and Empowerment
भारत सरकार, सोनीभा इण्डिया, नई दिल्ली
Government of India, CGO Complex, New Delhi

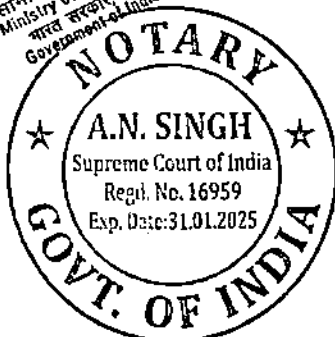

3.1.1. The Ministry of Housing and Urban Affairs (MoHUA), vide DO letter U-12012/1/2023-PLAN dated 17.11.2023, was informed of the directions passed by this Hon'ble Court, specifically, at para 96(1), (2). (6) and (7) and requested for necessary compliance and submission of Action Taken Report (ATR) to MoSJE (Annexure-I) (Page. No. 22).

3.1.2. Vide OM No. 13/6/2023-SBM-IV dated 16.01.2024, MoHUA has furnished the Action Taken Report to the Ministry of Social Justice and Empowerment (MoSJE). The actions taken by the MoHUA, briefly, are as follows:

3.1.2.1. In light of the fact that some level of confined space entry may be inevitable for certain complex maintenance or repair activities and the fact that Section 33(1) of the Prohibition of Employment of Manual Scavengers Act, 2013 Act mandates every local authority to use appropriate technological appliances for cleaning of sewers, septic tanks and other spaces within their control with a view to eliminate need for manual handling of excreta, safety gear has been reiterated as "appropriate technological appliance".

3.1.2.2. The necessary legislations, guidelines and instructions have been re-communicated to all

ए.स. बी. प्रसाद / S. B. PRASAD
अवर सचिव / Under Secretary
सामाजिक न्याय एवं अधिकारिता विभाग
Department of Social Justice and Empowerment
सामाजिक न्याय एवं अधिकारिता मंत्रालय
Ministry of Social Justice and Empowerment
भारत सरकार, सीओओ कॉम्प्लेक्स, नई दिल्ली
Government of India, CGO Complex, New Delhi

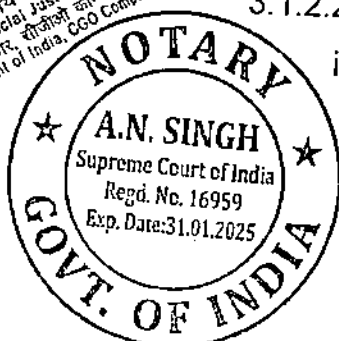

States/ UTs with directions to embody the same in their guidelines and direct their Urban Local Bodies (ULBs) to incorporate the same in their bye-laws.

3.1.2.3. Ministry has Institutionalized the offices of RSA and ERSU as the necessary provisions for removal of difficulty in getting the services delivered ensuring due safety and for also fixing accountability and responsibility if some mishap occurs particularly in small ULBs.

3.1.2.4. A draft Model Contract (for whenever contracts are awarded in conformity with the 2013 Act and Rules) has been prepared and circulated for comments from all State Urban Development Departments, MoSJE and other stakeholders before the Contract document is finalized.

3.1.3. A true copy of OM No. 13/6/2023-SBM-IV dated 16.01.2024 issued by the MoHUA is at Annexure-II (Page. No. 23-24).

4. This Hon'ble Court at para 96(2) directed, "*All States and Union Territories are likewise, directed to ensure that all departments, agencies, corporations and other agencies (by whatever name called) ensure that guidelines and directions framed by the Union are embodied in their own guidelines and directions; the states are specifically directed to ensure that such directions are applicable to all municipalities, and local bodies functioning within their*

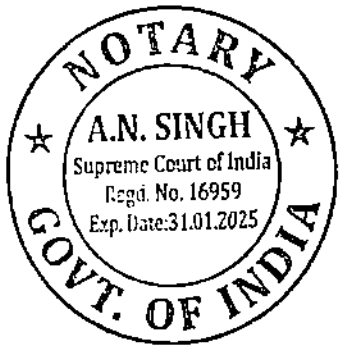

[Handwritten signature]

एस. बी. प्रसाद / S. B. PRASAD
अवर सचिव / Under Secretary
सामाजिक न्याय एवं अधिकारिता विभाग
Department of Social Justice and Empowerment
सामाजिक न्याय एवं अधिकारिता मंत्रालय
Ministry of Social Justice and Empowerment
भारत सरकार, सीजीओ कॉम्प्लेक्स, नई दिल्ली
Government of India, CGO Complex, New Delhi

territories;

4.1. In pursuance of the above quoted direction, following steps have been taken by the Union through MoSJE:

4.1.1. Vide letter No.U-12012/1/2023-PLAN dated 14.11.2023, Chief Secretaries of all the States / UTs were apprised of the aforesaid directions of the Hon'ble Court, particularly in directions passed in Para 96(2), (3), (4), (5), (6), (10) and (12), and were requested to take necessary action immediately for compliance of the said directions and submit an Action Taken Report to the MoSJE. A copy of this letter No.U-12012/1/2023-PLAN dated 14.11.2023 is annexed herewith as **Annexure-III (Page. No. 25-26).**

4.1.2. Vide DO letter No. U-12012/2/2023-PLAN dated 17.11.2023, MoHUA was informed of the aforesaid directions of the Hon'ble Court and was requested to comply with the directions and submit an ATR to this Ministry.

4.1.3. As on 29.01.2024, 24 States / UTs have submitted their respective ATR, which are annexed as **Annexure-IV-A to IV-X respectively (Page. No. 27-511).**

4.1.4. The ATR submitted by MoHUA vide their OM dated 16.01.2024, inter-alia, states that necessary legislations, guideines and instructions have been

एस. बी. प्रसाद / S. B. PRASAD
अवर सचिव / Under Secretary
सामाजिक न्याय एवं सशक्तिकरण विभाग
Department of Social Justice and Empowerment
सामाजिक न्याय एवं सशक्तिकरण विभाग
Ministry of Social Justice and Empowerment
भारत सरकार, सोनिया बंगला, पट्टा चौक
Government of India, CGO Complex, New Delhi

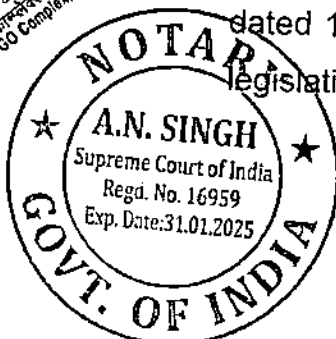

re-communicated to all States/UTs to embody MS Act, 2013 and MS Rules, 2013 in their guidelines and direct their ULBs to incorporate the same in their by-laws.

5. This Hon'ble Court at para 96(3) directed, "*The Union, State and Union Territories are directed to ensure that full rehabilitation (including employment to the next of kin, education to the wards, and skill training) measures are taken in respect of sewage workers, and those who die;*"

5.1. In pursuance of the above quoted direction, following steps have been taken by the Union through MoSJE:

5.1.1. The directions of the Hon'ble Court were communicated to all concerned authorities, i.e. States/UTs, Railway Board, Ministry of Defence and the ATR received from them is enumerated as under:

5.1.1.1. As on 29.01.2024, 24 States / UTs have submitted their ATR on the said directions alongwith other directions applicable to them. Copies of ATR received from the States/UTs are at Annexure-IV-A to IV-X (Page. No. 27-511).

5.1.1.2. Railway Board vide OM No. 2023/E(LL)/SCA/5 dated 29.12.2023 has informed the Respondent Union (MoSJE) that based on the information received from all

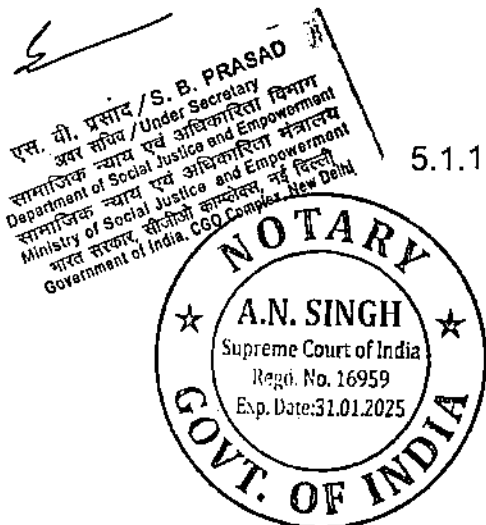

Zonal Railways & Production Units, all the directives issued by this Hon'ble Court in Paras 96 (3), (4), (5) and (10) have been fully complied with. A copy of the OM No. 2023/E(LL)/SCA/5 dated 29.12.2023 issued by the Railway Board is annexed herewith as Annexure-V (Page. No. 512).

5.1.1.3. Directorate General, Defence Estates, vide their letter dated 04.01.2024, has submitted that the directions of Hon'ble Court have already been issued to all cantonment boards to comply with the directions Issued by this Hon'ble Court, with special attention to the following points:

(i) Cantonment Boards to comply with MS Rules, 2013 to ensure that manual sewer cleaning is completely eradicated.

(ii) Full rehabilitation (including employment to the next of kin, education to the wards, and skill training) measures are taken in respect of sewage workers, and those who die.

(iii) Payment of increased amount of compensation i.e. Rs 30 lakhs for sewer deaths. In the event, dependents of any victim have not been paid such amount, the above amount shall be payable to them hereafter as compensation.

(iv) Payment of compensation of Rs 20 lakhs, in

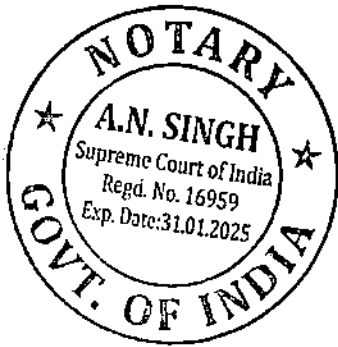

एस. बी. प्रसाद / S. B. PRASAD
अवर सचिव एवं अधिकारिता विभाग
Department of Social Justice and Empowerment
सामाजिक न्याय एवं अधिकारिता मंत्रालय
Ministry of Social Justice and Empowerment
भारत सरकार, सीजीओ कॉम्प्लेक्स, नई दिल्ली
Government of India, CGO Complex, New Delhi

the case of sewage victims suffering disabilities, depending upon the severity of disabilities. Minimum compensation shall not be less than Rs 10 lakhs.

A true copy of the letter dated 04.01.2024 issued by the Directorate General, Defence Estates to the MoSJE is annexed herewith as Annexure-VI (Page. No. 513).

5.1.1.4. Ministry of Social Justice and Empowerment (MoSJE) has issued a letter No. PMD-17/1/2024-PM-DAKSH dated 09.01.2024 to all States/UTs and as also to the National Safai Karamchari Finance and Development Corporation (NSKFDC) for necessary compliance of the directions passed by this Hon'ble Court. A true copy of letter No. PMD-17/1/2024-PM-DAKSH dated 09.01.2024 issued by the MoSJE to the NSKFDC is annexed herewith as Annexure-VII. (Page. No. 514). A true copy of letter No. PMD-17/1/2024-PM-DAKSH dated 09.01.2024 issued by the MoSJE to the States and UTs is annexed herewith as Annexure VIIA (Page. No. 515-521).

6. This Hon'ble Court at para 96(4) directed, "The court hereby directs the Union and the States to ensure that the compensation for sewer deaths is increased (given that the previous amount fixed, i.e., ₹ 10 lakhs) was made

ए.बी. प्रसाद / S. B. PRASAD
अवर सचिव / Under Secretary
सामाजिक न्याय एवं अधिकारिता विभाग
Department of Social Justice and Empowerment
सामाजिक न्याय एवं अधिकारिता विभाग
Ministry of Social Justice and Empowerment
सर्वोच्च न्यायालय, संसदीय भवन, नई दिल्ली
Government of India, CGO Complex, New Delhi

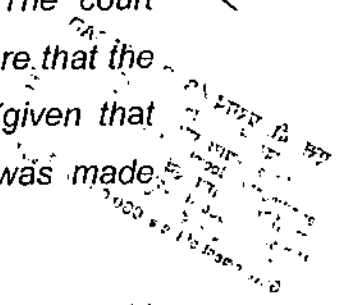
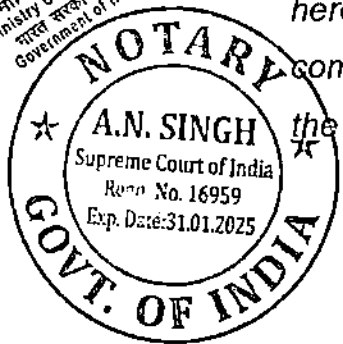

applicable from 1993. The current equivalent of that amount is Rs. 30 lakhs. This shall be the amount to be paid, by the concerned agency, i.e., the Union, the Union Territory or the State as the case may be. In other words, compensation for sewer deaths shall be ₹ 30 lakhs. In the event, dependents of any victim have not been paid such amount, the above amount shall be payable to them. Furthermore, this shall be the amount to be hereafter paid, as compensation."

Further at Para 96(5) it was directed, "Likewise, in the case of sewer victims suffering disabilities, depending upon the severity of disabilities, compensation shall be disbursed. However, the minimum compensation shall not be less than ₹ 10 lakhs. If the disability is permanent, and renders the victim economically helpless, the compensation shall not be less than ₹ 20 lakhs."

6.1. It is submitted that the directions passed by this Hon'ble Court were communicated to all concerned authorities and the response received from them so far is as under:

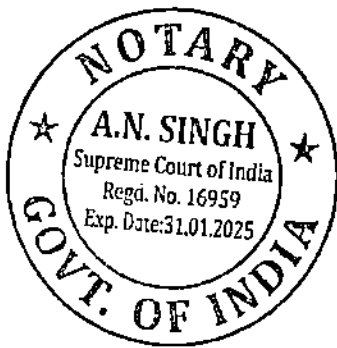

6.1.1. Vide letter dated 29.12.2023, Railway Board has furnished that the directions regarding payment of compensation with increased amount of Rs. 30.00 lakh for sewer death as well as payment of compensation of Rs.20 lakh in case of sewer victims suffering disabilities, depending upon severity of the disability (minimum compensation not to be less than Rs.10.00 lakh) have been duly complied with over all the Zonal Railways &

एस. बी. प्रसाद / S. B. PRASAD
अस. सचिव / Under Secretary
सामाजिक न्याय एवं अधिकारिता विभाग
Department of Social Justice and Empowerment
सामाजिक न्याय एवं अधिकारिता मंत्रालय
Ministry of Social Justice and Empowerment
मंत्रालय भवन, सीजीओ कॉम्प्लेक्स, नई दिल्ली
Government of India, CGO Complex, New Delhi

Production Units. Letter dated 29.12.2023 issued by the Railway Board has been annexed herewith as Annexure-V(Page. No. 512).

6.1.2. Directorate General, Defence Estates, vide communication dated 04.01.2024, has submitted that directions with regard to the above judgment of Hon'ble Court have already been issued to all the Cantonment Boards for necessary compliance (Annexure-VI) (Page. No. 513).

6.1.3. The ATR received from the States/UTs with regard to directions of Hon'ble Court is also at Annexure-IV-A to IV-X (Page No. 27-511).

7. This Hon'ble Court at para 96(6) directed, *"The appropriate government (i.e., the Union, State or Union Territories) shall devise a suitable mechanism to ensure accountability, especially wherever sewer deaths occur in the course of contractual or "outsourced" work. This accountability shall be in the form of cancellation of contract, forthwith, and imposition of monetary liability, aimed at deterring the practice."*

Further, at para 96(7) directed, *"The Union shall devise a model contract, to be used wherever contracts are to be awarded, by it or its agencies and corporations, in the concerned enactment, such as the Contract Labour (Prohibition and Regulation Act), 1970, or any other law, which mandates the standards – in conformity with the 2013 Act, and rules, are strictly followed, and in the event of any mishap, the agency would lose its contract, and possibly blacklisting. This model shall also be used by all*

एस. बी. प्रसाद / S. B. PRASAD
अवर सचिव / Under Secretary
सामाजिक न्याय एवं अधिकारिता विभाग
Department of Social Justice and Empowerment
सामाजिक न्याय एवं अधिकारिता मंत्रालय
Ministry of Social Justice and Empowerment
भारत सरकार, सोनीभा कॉम्प्लेक्स, नई दिल्ली
Government of India, CGO Complex, New Delhi

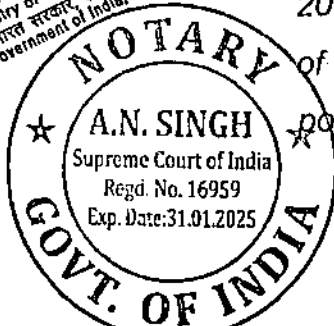

States and Union Territories.”

7.1. In pursuance of the above stated directions, following steps have been taken by the Answering Respondent

7.1.1. Vide DO letter dated 17.11.2023, MoHUA was requested to take necessary action for its compliance and submit ATR to MoSJE.

7.1.2. Vide letter dated 04.01.2024, MoHUA has informed that a draft model contract for engagement of private sanitation service operators by cities/States has been formulated and the same has been circulated to all States/UTs for their comments.

7.1.3. With regard to devising suitable mechanism to ensure accountability, specially wherever sewer death occurred in the course of contractual or outsourced work, MoHUA, vide its OM dated 16.01.2024, has stipulated that the MS Act, 2013 itself provides under Section 38 (1) that the Central Government may make such provisions, not inconsistent with the provisions of this Act, as may appear to be necessary or expedient for the removal of the difficulty. Accordingly, MoHUA has institutionalized the officers of Responsible Sanitation Authority (RSA) and Emergency Response Sanitation Unit (ERSU) as the necessary provisions for removal of difficulty in getting the service delivered ensuring due septic

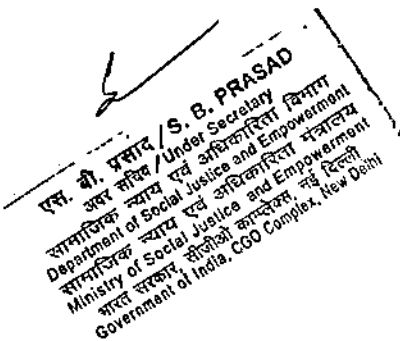
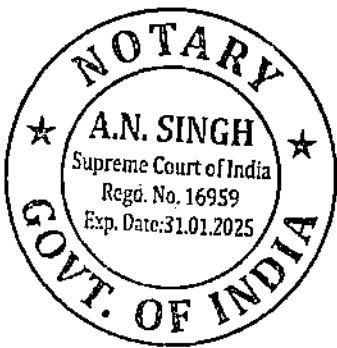

and for also fixing accountability and responsibility if some mishaps happen, particularly in small ULBs.

8. This Hon'ble Court directed at para 96(8), "*The NCSK, NCSC, NCST and the Secretary, Union Ministry of Social Justice and Empowerment, shall, within 3 months from today, draw modalities for the conduct of a National Survey. The survey shall be ideally conducted and completed in the next one year.*"

8.1. In pursuance of this direction, following steps have been taken by the Respondent:

8.1.1. MoSJE has drafted survey guidelines along with survey form (self-declaration form) by incorporating the inputs received from NCSC, NCSK, NCST and NSKFDC. The draft guidelines so formulated has been submitted to NALSA for their comments, vide letter dated 22.12.2023. A true copy of the letter dated 22.12.2023 issued by the Respondent is annexed herewith as **Annexure-VIII (Page. No. 522-523)**. It is submitted that comments from NALSA are awaited. After the comments of NALSA are received, the draft guidelines, after due approval of the competent authority, would be circulated to all States/UTs for commencing survey of manual scavengers as per the guidelines/modalities.

एस. बी. प्रसाद / S. B. PRASAD
अवर सचिव एवं अधिकारिता विभाग
सामाजिक न्याय एवं अधिकारिता विभाग
Department of Social Justice and Empowerment
सामाजिक न्याय एवं अधिकारिता विभाग
Ministry of Social Justice and Empowerment
एन.टी. रोड, सी.ओ. कॉम्प्लेक्स, नई दिल्ली
Government of India, CGO Complex, New Delhi



This Hon'ble Court directed at para 96(9), "*To ensure that*

the survey does not suffer the same fate as the previous ones, appropriate models shall be prepared to educate and train all concerned committees."

9.1. In pursuance of the above direction, following steps have been taken by the Respondent

9.1.1. The model for providing training to all concerned committees has been prepared and the same has been circulated to all States/UTs for necessary compliance. A copy of the Training Manual For Survey of Manual Scavengers is annexed herewith as **Annexure-IX(Page. No. 524-571)**.

10. This Hon'ble Court directed at para 96(10), "*The Union, State and Union Territories are hereby required to set up scholarships to ensure that the dependents of sewer victims, (who have died, or might have suffered disabilities) are given meaningful education.*"

10.1. In pursuance of this direction, following steps have been taken by the Respondent:

10.1.1. MoSJE is providing scholarship to the dependents of persons engaged in unclean occupation. Vide letter dated 18.01.2024, MoSJE has issued necessary directions to all States/UTs to take appropriate action to include the dependent of sewer victims (who have died or might have suffered disabilities) are given meaningful education. A copy of letter dated 18.01.2024 is annexed herewith as **Annexure-X(Page. No. 572)**.



एस. बी. प्रसाद / S. B. PRASAD
अवर सचिव / Under Secretary
सामाजिक न्याय एवं अधिकारिता विभाग
Department of Social Justice and Empowerment
सामाजिक न्याय एवं अधिकारिता मंत्रालय
Ministry of Social Justice and Empowerment
भारत सरकार, संजोला कॉम्प्लेक्स, नई दिल्ली
Government of India, CGO Complex, New Delhi

10.1.2. Railway Board, vide letter dated 29.12.2023, has issued the directions to all its Zonal Railways and Production Units to comply with the said judgment of the Hon'ble Court.

10.1.3. Vide letter dated 14.11.2023, Chief Secretaries of all the States / UTs, were informed of the said directions of the Hon'ble Court and requested for necessary compliance and submission of action taken report to MoSJE, which are annexed at Annexure-III (Page. No. 25-26).

10.1.4. The ATR received from States/UTs with regard to the above directions of the Hon'ble Court is at Annexure-IV-A to IV-X (Page No. 27-511).

11. This Hon'ble Court at para 96(11) directed, "*The National Legal Services Authority (NALSA) shall also be part of the consultations, toward framing the aforesaid policies. It shall also be involved, in co-ordination with state and district legal services committees, for the planning and implementation of the survey. Furthermore, the NALSA shall frame appropriate models (in the light of its experience in relation to other models for disbursement of compensation to victims of crime) for easy disbursement of compensation.*"

एस. बी. प्रसाद / S. B. PRASAD
अवर सचिव / Under Secretary
सामाजिक न्याय एवं अधिकारिता विभाग
Department of Social Justice and Empowerment
सामाजिक न्याय एवं अधिकारिता मंत्रालय
Ministry of Social Justice and Empowerment
भारत सरकार, सोनीजी कॉम्प्लेक्स, नई दिल्ली
Government of India, CGO Complex, New Delhi

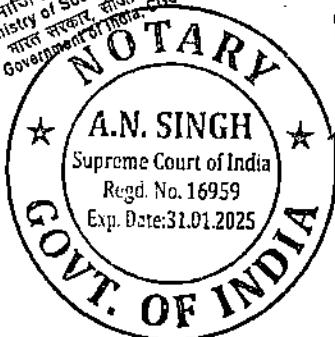

11.1. Pursuant to this direction, following steps have been taken by the Respondent –

11.1.1. Vide letter dated 22.12.2023, the draft

modalities/guidelines for survey of manual scavengers has been sent to NALSA for their comments before the draft guidelines for survey is circulated to the States/UTs for commencing the survey of manual scavengers. Vide the said letter, NALSA has also been requested to formulate a model of disbursement of compensation. The response from NALSA is awaited.

12. This Hon'ble Court at para 96(12) directed "*The Union, State and Union Territories are hereby directed to ensure co-ordination with all the commissions (NCSK, NCSC, NCST) for setting up of state level, district level committees and commissions, in a time bound manner. Furthermore, constant monitoring of the existence of vacancies and their filling up shall take place.*"

12.1. Pursuant to the above, following steps have been taken by the Respondent:

12.1.1. Vide letter dated 16.01.2024, NCSK has informed to MoSJE that 31 States/UTs have constituted Vigilance Committee as well as State Monitoring Committees, whereas 5 States/UTs have not informed in this regard. The status of Vigilance Committees and State Monitoring Committees in the States/UTs as on 31.12.2023 is annexed as **Annexure-XI (Page. No. 573-579)**.

12.1.2. Vide the said letter, NCSK has informed that 11 States/UTs have State Commission for

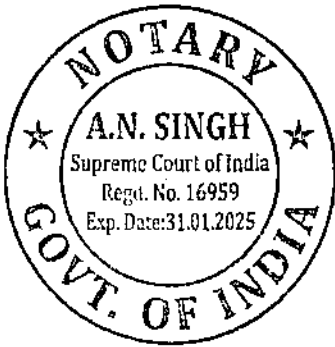

एन. बी. प्रसाद / S. B. PRASAD
अवर सचिव / Under Secretary
सामाजिक न्याय एवं अधिकारिता विभाग
Department of Social Justice and Empowerment
सामाजिक न्याय एवं अधिकारिता मंत्रालय
Ministry of Social Justice and Empowerment
भारत सरकार, सोनीपत कम्प्लेक्स, नई दिल्ली
Government of India, CGO Complex, New Delhi

Safai Karamcharis, whereas 16 States/UTs have designated agencies to look after the work of State Commission for Safai Karamcharis. The status as on 31.12.2023 as furnished by NCSK is enclosed as Annexure-XI(Page. No. 573-579).

13. This Hon'ble Court at para 96(13) directed "NCSK, NCSC, NCST and the Union government are required to coordinate and prepare training and education modules, for information and use by district and state level agencies, under the 2013 Act."

13.1 The Respondent Union has mentioned the action taken in respect of this direction of the Hon'ble Court in its submission at para 9.1.1 (Annexure-IX) (Page. No. 524-571).

14. This Hon'ble Court at para 96 (14) directed, "A portal and a dashboard, containing all relevant information, including the information relating to sewer deaths, and victims, and the status of compensation disbursement, as well as rehabilitation measures taken, and existing and available rehabilitation policies shall be developed and launched at an early date."

14.1. In pursuance of this direction, following steps have been taken by the Respondent-

14.1.1. NAMASTE Portal and dash board containing the information as pointed out by the Hon'ble Court in the aforesaid directions are under development.

एस. बी. प्रसाद / S. B. PRASAD
अवर सचिव / Under Secretary
सामाजिक न्याय एवं अधिकारिता विभाग
Department of Social Justice and Empowerment
सामाजिक न्याय एवं अधिकारिता मंत्रालय
Ministry of Social Justice and Empowerment
भारत सरकार, सीजीओ कॉम्प्लेक्स, नई दिल्ली
Government of India, CGO Complex, New Delhi

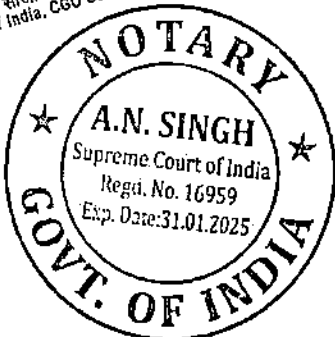

IN THE HON'BLE SUPREME COURT OF INDIA

WRIT PETITION (C) NO. 324 OF 2020

IN THE MATTER OF:

DR. BALRAM SINGH

...PETITIONER

VERSUS

UNION OF INDIA & ORS.

...RESPONDENT(S)

I, Shree Bhagwan Prasad, S/o Shri R.B. Prasad aged about 53 years, currently posted as Under Secretary, Ministry of Social Justice and Empowerment at New Delhi, do hereby solemnly affirm and state as hereunder:

1. That I am duly authorized by the Ministry of Social Justice and Empowerment to swear this affidavit and I am conversant with the facts and circumstances of the present case and am thereby competent to
2. That I have perused the accompanying status report and state that the averments contained therein are true and correct to the best of my knowledge and record. No part of it is false and nothing material has been concealed therefrom.

प्र. वी. प्रसाद / S. B. PRASAD
अवर सचिव / Under Secretary
सामाजिक न्याय एवं अधिकारिता विभाग
Department of Social Justice and Empowerment
सामाजिक न्याय एवं अधिकारिता विभाग
Ministry of Social Justice and Empowerment
भारत सरकार, सोनीभो बंगला, नई दिल्ली
Government of India, CGO Complex, New Delhi

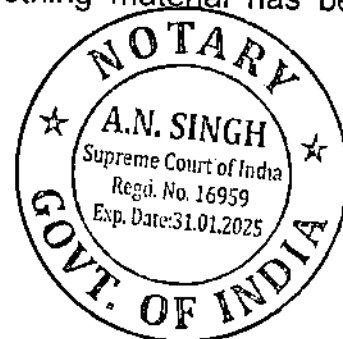

3. That the annexures In the accompanying petition are true and translated copies of their respective originals.

DEPONENT

एस. बी. प्रसाद / S. B. PRASAD
अवर सचिव / Under Secretary
सामाजिक न्याय एवं अधिकारिता विभाग
Department of Social Justice and Empowerment
सामाजिक न्याय एवं अधिकारिता मंत्रालय
Ministry of Social Justice and Empowerment
भारत सरकार, सीजीओ कॉम्प्लेक्स, नई दिल्ली
Government of India, CGO Complex, New Delhi

VERIFICATION

30 JAN 2024

Verified at New Delhi on this the 30th day of January, 2024 that the contents of above affidavit are true and correct to the best of my knowledge and belief. No part of it is false and nothing material has been concealed therefrom.

I Identify the deponent who has Signed/Put T.I. in my presence





DEPONENT

एस. बी. प्रसाद / S. B. PRASAD
अवर सचिव / Under Secretary
सामाजिक न्याय एवं अधिकारिता विभाग
Department of Social Justice and Empowerment
सामाजिक न्याय एवं अधिकारिता मंत्रालय
Ministry of Social Justice and Empowerment
भारत सरकार, सीजीओ कॉम्प्लेक्स, नई दिल्ली
Government of India, CGO Complex, New Delhi

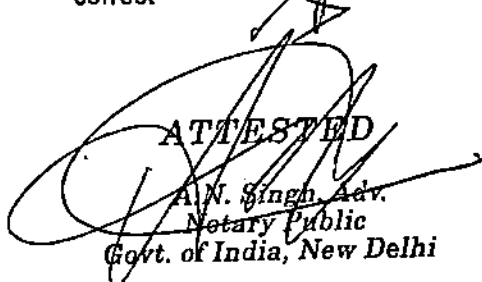

Certified that the above Named Deponent Identify by Shri/Smt. S. B. Prasad Solemnly affirmed before me at Delhi S. No. 16959 The contents of the affidavit which have been read & explained to me are true and correct
Notary

ATTESTED

A.N. Singh, Adv.
Notary Public
Govt. of India, New Delhi

30 JAN 2024

21

538688/2023/DO Secretary
सावरभ गग, मा.प्र.से.
सचिव
Saurabh Garg, IAS
Secretary



Annexure-I
भारत सरकार
सामाजिक न्याय और अधिकारिता मंत्रालय
सामाजिक न्याय और अधिकारिता विभाग
Government of India
Ministry of Social Justice & Empowerment
Department of Social Justice & Empowerment

DO No. U-12021/1/2023-PLAN

November 17, 2023

Dear Manoj,

You may be aware that Dr. Balram Singh filed the WP (C) No. 324/2020 V/s UoI through Ministry of Environment and all the States and UTs before Hon'ble Supreme Court of India and prayed for directions for implementation of various rules including "The Employment of Manual Scavengers and Construction of Dry Latrines (Prohibition) Act, 1993" and "The Prohibition of Employment as Manual Scavengers and their Rehabilitation Act, 2013".

2. The matter was taken up with all stakeholders including State Govts / UTs; Ministries / Departments of Government of India and Commissions / Corporations of GoI and based on the input provided by all, affidavit, was filed before Hon'ble Supreme Court.

3. Hon'ble Court vide order dated 20.10.2023 (copy enclosed) has directed for compliance of the following observations and listed the case for 01.02.2024.

- Appropriate measures be taken, policies be framed and directions be issued to all statutory bodies to ensure eradication of manual sewer cleaning in phased manner [para 96 (1)];
- MS Act, 2013; MS Rules 2013 and guidelines framed by the Union are embodied in States/ UTs guidelines and directions are applicable to all Municipalities and Local Bodies [para 96 (2)];
- Devise suitable mechanism to ensure accountability, especially wherever sewer deaths occur in the course of contractual or "outsourced" work [para 96 (2)];
- Devise a model contract, to be used wherever contracts are to be awarded, in conformity with 2013 Acts and Rules [para 96 (7)];

4. I will be glad if you could look into the matter personally for necessary compliances of the Hon'ble Supreme Court's orders and provide an Action Taken Report to this Department at the earliest.

Regards,

Yours sincerely,

Saurabh Garg

(Saurabh Garg)

Shri Manoj Joshi
Secretary
Ministry of Housing and Urban Affairs
Nirman Bhawan, New Delhi -110011

Enclosure : As above

//True copy//

22

F. No. 13/6/2023-SBM-IV
 Government of India
 Ministry of Housing and Urban Affairs

Nirman Bhawan, New Delhi
 Dated the 16th January 2024

OFFICE MEMORANDUM

Subject: Civil Writ Petition (PIL) No. 324 of 2020 in the matter of Balram Singh v/s Union of India and others pending before the Hon'ble Supreme Court of India- regarding.

The undersigned is directed to refer to MoSJE's DO letter No U-12012/01/2023 dated 17 November, 2023 and subsequent communications dated 2nd & 12th January, 2024 on the subject mentioned above and to say that the action points pertaining to this Ministry and the action taken thereof is tabulated below:-

Action Point	Action Taken
A) Appropriate measures to be taken, policies to be framed and directions to be issued to all statutory bodies to ensure eradication of manual sewer cleaning in phased manner.	<p>MoHUA recognizes the gravity of the issue and understands the human cost associated. The Ministry is firmly committed to implementing the Supreme Court's direction for phased eradication of manual entry into sewers.</p> <p>In view of foregoing, the guidelines provided to States from time to time have incorporated a paradigm shift aligned with the Hon'ble Supreme Court's directive; emphasizing on the use of appropriate machinery and mandating strict adherence to safety protocols, and SOPs.</p> <p>MoHUA also has taken cognizance that some level of confined space entry may be inevitable for certain complex maintenance or repair activities, as is practiced even in developed nations. Accordingly, protocols and advisories take into account such extraordinary circumstances where confined space entry is unavoidable in which several measures including provision of well trained and equipped, motivated sewer entry professionals, establishment of institutional mechanisms and specific safety gear are mandated and accountability/ responsibility is clearly defined.</p> <p>Sec 33. (I) of the Prohibition of Employment of Manual Scavengers (PEMSR) Act, 2013 Act provides that it shall be the duty of every local authority and other agency to use appropriate technological appliances for cleaning of sewers, septic tanks and other spaces within their control</p>

//True copy//

	<p>with a view to eliminating the need for the manual handling of-excreta in the process of their cleaning.</p> <p>Safety Gear has been reiterated as the "appropriate technological appliance" which prevents one from coming in contact with excreta but ensures that cleaning activity is also carried out with safety and dignity as it will be inappropriate to engage heavy costly machinery where an equally safe, but less expensive solution can be provided.</p> <p>This approach balances the practical realities of sanitation engineering with the imperative of safeguarding human lives and dignity.</p>
B) MS Act, 2013; MS Rules 2013 and Guidelines framed by the Union are to be embodied in States/UTs Guidelines and directions in this regard to be given to all municipalities and local bodies.	The necessary legislations, guidelines and instructions have been re-communicated to all States/ UTs with instructions to embody in their guidelines and direct their ULBs to incorporate in their Byelaws.
C) Devise suitable mechanism to ensure accountability, especially wherever sewer deaths occur in the course of contractual or "outsourced" work.	Since the Act itself provides under Sec 38(1) that if any difficulty arises in giving effect to the provisions of this Act, the Central Government may, by order published in the Official Gazette, make such provisions, not inconsistent with the provisions of this Act, as may appear to it to be necessary or expedient for the removal of the difficulty: Accordingly, the Ministry has institutionalized the offices of RSA and ERSU as the necessary provisions for removal of difficulty in getting the service delivered ensuring due safety and for also fixing accountability and responsibility if some mishap happens, particularly in small ULBs.
D) Devise a model contract, to be used wherever contracts are to be awarded, in conformity with 2013 Acts and Rules.	The draft Model Contract has been prepared and stands circulated for comments to all States Urban Development departments and to the Ministry of Social Justice and Empowerment for their stakeholders' comments before the Contract Document is finalized

HB Yadav

(Binod Kr. Yadav)^{16.1.24}

Under Secretary (SBM-II)

To
Shri SB Prasad,
Under Secretary
Department of Social Justice and Empowerment

17.1.24

[Signature]



सत्यमेव जयते

भारत सरकार
सामाजिक न्याय और अधिकारिता मंत्रालय
सामाजिक न्याय और अधिकारिता विभाग
MINISTRY OF SOCIAL JUSTICE AND
EMPOWERMENT
DEPARTMENT OF SOCIAL JUSTICE AND
EMPOWERMENT

B-2 Ground Floor,
Pt. Deendayal Antyodaya
Bhawan, CGO Complex,
New Delhi-110003

संख्या/No U-12021/1/2023-PLAN

दिनांक/Date. 14th November, 2023

To,
The Chief Secretaries of all the States / UTs

Subject: Writ Petition (Civil) No. 324 of 2020 filed by Dr. Balram Singh vs Union of India & Ors before Supreme Court of India -reg.

Madam/Sir

I am directed to refer to the subject mentioned above and to enclose herewith a copy of Judgement dated 20.10.2023 of Hon'ble Supreme Court in Writ Petition (Civil) No. 324 of 2020 filed by Dr. Balram Singh vs Union of India & Ors.

2. The matter was taken up with State Govts / UTs many times including DO letter dated 26.05.2023 (copy enclosed) of Secretary D/o Social Justice and Empowerment and based on the input provided by a/c, affidavit, was filed before Hon'ble Supreme Court.
3. Hon'ble Court vide order dated 20.10.2023 has directed for compliance of the following observations and listed the case for 01.02.2024.

- MS Act, 2013; MS Rules 2013 and guidelines framed by the Union are embodied in States/ UTs guidelines and directions are applicable to all municipalities and local bodies [para 96 (2)] ;
- Full rehabilitation (including employment to the next of kin, education to the wards, and skill training) of sewage workers, and those who die [para 96 (3)];
- Payment of compensation with increased amount i.e., ₹ 30 lakhs for sewer deaths. In the event, dependents of any victim have not been paid such amount, the above amount shall be payable to them, hereafter as compensation [para 96 (4)];
- Payment of compensation of Rs. 20 lakhs, in the case of sewer victims suffering disabilities, depending upon the severity of disabilities. Minimum compensation shall not be less than ₹ 10 lakhs [para 96 (5)] ;

//True copy//

- Devise suitable mechanism to ensure accountability, especially wherever sewer deaths occur in the course of contractual or "outsourced" work [para 96 (6)] ;
- Set up scholarships to ensure that the dependents of sewer victims, (who have died, or might have suffered disabilities) are given meaningful education [para 96 (10)];
- Ensure establishment of State Commission for Safai Karmacharis and all Committees mentioned in MS Act, 2013 and MS Rules 2013 including State Monitoring Committee, State Level Survey Committee, District Vigilance Committee and District Level Survey Committee by 30.11.2023 [para 96 (12)].

4. It is therefore requested that necessary action may be taken immediately in compliance of observations of Hon'ble Supreme Court. Necessary guidelines for implementation of survey etc. are being finalized and will be issued shortly. It is requested that Principal Secretary / Secretary, Social Welfare dealing with Safai Karmacharis may be nominated as Nodal Officer for the case and his/her details may be provided immediately through email id srivastwa.sk@nic.in / manojk.jha@nic.in. The status of implementation of the judgement of the Hon'ble Supreme Court may be sent by 31.12.2023 so that status could be filed before the Court.

This issues with the approval of Secretary.

Encls: As above

Yours faithfully,

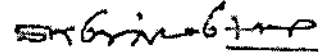

(S.K. Srivastwa)

Deputy Secretary to the Govt. of India

Tele No. 011 24369841

E-mail: srivastwa.sk@nic.in



//True copy//

By Regd AD

Annexure IV-A



GOVERNMENT OF GOA
DIRECTORATE OF SOCIAL WELFARE
18TH JUNE ROAD, PANAJI-GOA
Tel.No.2223784,2232257 Fax No. 2228172

No. 86-2-12-13/SDB/Part-III/6556 Dated:28/12/2023

To

Shri S.K Srivastwa
Deputy Secretary,
Ministry of Social Justice and Empowerment,
Department of Social Justice and Empowerment,
B-2, Ground Floor, Pt Deendayal Antyodaya Bhawan,
CGO Complex, New Delhi- 110003

Sub : Civil Writ Petition (PIL) No 324 OF 2020 in the matter of
Dr Balram Singh V/s Union of India and Others pending before
the Supreme Court of India.

Sir,

With reference to your Office D.O Letter No U-12012/1/2023-PLAN dated 14/11/2023 and the video conference held on 15th December, 2023 on the subject cited above, I hereby furnish the Action Taken Report in a prescribed format as Annexure A on the directions of the Supreme Court of India for your kind reference and necessary action.

Yours faithfully,

(Ajit Panehwadkar)

Director of Social Welfare &
Ex-Officio Addl. Secretary (SW)

Encl : as above

//True copy//

SUPREME COURT JUDGEMENT ON WP(C) No 324/2020

Annexure A

Directions	Action taken
(1) MS Act, 2013; MS Rules 2013 and guidelines framed by the Union are to be embodied in States/ UTs guidelines and directions in this regard to be given to all municipalities and local bodies [para 96 (2)] (Action by: M/o HUA, D/o DWS, M/o Railways, M/o Defence and States/UTs)	Directions will be given to all municipalities and local bodies once guidelines framed by the Union are received
(2) Full rehabilitation (including employment to the next of kin, education to the wards, and skill training) of sewage workers, and those who die [para 96 (3)] (Action by: M/o Railways, M/o Defence and States/UTs)	Instructions will be issued to the concerned departments regarding Measures for full rehabilitation which will be devised.
(3) Payment of compensation with increased amount i.e., ₹ 30 lakhs for sewer deaths. In the event, dependents of any victim have not been paid such amount, the above amount shall be payable to them, hereafter as compensation [para 96 (4)] (Action by: States/UTs, M/o Railways, M/o Defence , NCSK)	Notice issued to the hotel owner of Shell Top Inn Santa Cruz to settle the pending balance payment of compensation to the 3 family members of the deceased (copy enclosed)
4) Payment of compensation of Rs. 20 lakhs, in the case of sewer victims suffering disabilities, depending upon the severity of disabilities. Minimum compensation not to be less than ₹ 10 lakhs [para 96 (5)] (Action by: States/UTs, M/o Railways and M/o Defence)	To be noted for future compliance
(5) Devise suitable mechanism to ensure accountability, especially wherever sewer deaths occur in the course of contractual or "outsourced" work [para 96 (6)] (Action by: M/o Housing and Urban Affairs, D/o DWS and States/UTs)	Instructions will be issued to the concerned departments regarding Mechanism to ensure accountability to be devised.

//True copy//

<p>(6) Set up scholarships to ensure that the dependents of sewer victims, (who have died, or might have suffered disabilities) are given meaningful education [para 96 (10)]. (Action by: M/o Railways, M/o Defence, States/UTs and SCD (DoSJE))</p>	<p>The State is implementing the centrally sponsored scheme of pre -- matric scholarship to the children of those engaged in unclean occupation also letters are sent to Directorate of Education, Higher education, Technical Education, Skill Development and Entrepreneurship and Tribal welfare for obtaining information on state and central scholarship scheme. Reply in this regard is awaited.</p>
<p>(7) Establishment of State Commission for Safai Karmacharis and all Committees mentioned in MS Act, 2013 and MS Rules 2013 including State Monitoring Committee, State Level Survey Committee, District Vigilance Committee and District Level Survey Committee by 30.11.2023 [para 96 (12)]. (Action by: NCSK, NCST, NCSC and States/UTs)</p>	<p>“Goa Commission for SC and ST to perform the functions specified for National Commission for Safai Karmacharis”(copy enclosed) State Monitoring Committee is reconstituted vide Notification No 83-13-2023-24/SDB/5646 dated 8-11/2023(Copy enclosed) District Vigilance Committee vide Notification No 86-2-2015-16-SDB/Part-II/1178 dated 25/5/2018(Copy enclosed) State Level Survey Committee and District Level Survey Committee to be constituted</p>



Director of Social Welfare
Panaji-Goa

//True copy//





GOA COMMISSION FOR SC & ST
Inward No. 168
Date 20/2/14

GOVERNMENT OF GOA
DIRECTORATE OF SOCIAL WELFARE
1810 JUNE ROAD, PANAJI-GOA
Tel.No.2223784, 2232257
Fax No. 2228172

19/c
11/

No. 85-5-98/PART/(Vol.I)SDB/ Q/11/8 Dated: 18/2/2014

25

NOTIFICATION

In pursuance to section 32(1) of "The Prohibition of the Employment as a Manual Scavenger and their Rehabilitation Act, 2013", Government of Goa is pleased to notify "Goa Commission for Scheduled Caste and Scheduled Tribe" to perform the functions specified for National Commission for Safai Karmacharies.

This notification is issued with the approval of the Government vide U.O No. 1238/F dated 20/1/2014 and shall come into force from the date of publication of Notification in the official Gazette.

By order & in the Name of
Governor of Goa

(Meena Naik Goltekar)

21/2/14

(Smt. Meena Naik Goltekar)

Directorate of Social Welfare &
Ex-Officio/Joint Secretary (SW)

Copy to: Chief Executive Officer, Goa State Commission for Sc/ST, Shramshakti Bhavan, Pulto, Panaji-Goa for information.

True copy//



GOVERNMENT OF GOA
DIRECTORATE OF SOCIAL WELFARE
18TH JUNE ROAD, PANAJI-GOA

Phone: (0832)-2223784, 2232257; Fax: (0832)-2228172

No- 83-13-2023-24/SDB | 5646

Dated: 8/10/2023

NOTIFICATION

In exercise of the powers conferred by chapter VII section 26 (I) Government is pleased to constitute a State Monitoring Committee under The Prohibition of Employment as Manual Scavengers and their Rehabilitation Act 2013.

1.	Hon'ble Chief Minister or Minister nominated by him.	Chairperson, Ex, Officio
2.	Hon'ble Minister for Social Welfare	Member
3.	Chairman "Goa State Commission for Safai Karmacharis"	Member
4.	Chairman "Goa State Commission for Scheduled Caste and Scheduled Tribe"	Member
5.	Representative of National Commission for Scheduled Caste and Safai Karmacharis	Member
6.	Shri Pravin Arlekar, Hon'ble MLA, Pernem Constituency.	Member
7.	Shri. Antonio Vas, Hon'ble MLA, Cortalim Constituency.	Member
8.	Secretary (Home)	Member
9.	Secretary (Panchayat Raj)	Member
10.	Secretary (Urban Development)	Member
11.	Director General of Police, Panaji.	Member, Ex- Officio
12.	Director of Panchayat	Member, Ex- Officio
13.	Director of Urban Development	Member, Ex- Officio

//True copy//

22/c

14.	One representative of All Goa Municipal Employees Association, St. Inez, Panaji Goa.	Member
15.	One Women representative of CCP Employees Union, Ramakant Appt. M.G. Road Panaji Goa.	Member
16.	One representative of Goa Municipal Workers Union, Panaji Goa.	Member
17.	One Women representative of M/s Bapu Environmental Social Service organization, G-2, Verenkar, DurgabhatPonda Goa.	Member
18.	Manager of State Bank Of India- Lead Bank	Member, Ex- Officio
19.	Secretary (Social Welfare)	Member Secretary

The State Monitoring Committee shall meet every six months.

By Order and in the name of the
Governor of Goa

(AJIT PANCHWADKAR)
Director of Social Welfare
& Ex-Officio Addl. Secretary (SW)

Copy to: -

1. The Director, Goa Printing Press, Panaji for favour of publication in the Official Gazette in the next issue and supply of five copies of the same to this office for records.
2. All the above mentioned Members.
3. All Heads of Departments/ Offices.
4. Guard file.
5. Office copy.

//True copy//



GOVERNMENT OF GOA
DIRECTORATE OF SOCIAL WELFARE
18TH JUNE ROAD, PANAJI-GOA
Tel.No.2223784,2232257, Fax No. 2228172

No.86-2-2015-16-SDB/Part -II/1178 Dated: 25/5/2018

NOTIFICATION

In exercised of the powers conferred by chapter VII Point No. 24 (I) Government is please to constitute a Vigilance Committee for North Goa District and South Goa District under The Prohibition of Employment as Manual Scavengers and their Rehabilitation Act, 2013.

North Goa District

1.	District Magistrate & Collector, North Goa.	Chairperson, Ex-Officio
2.	Shri Manohar Azgaonkar Members Of Legislative Assembly (SC)	Member, Ex-Officio
3.	Superintendent of Police (North Goa)	Member, Ex-Officio
4.	Director of Panchayat	Member, Ex-Officio
5.	Director of Municipal Administration	Member, Ex-Officio
6.	Commissioner of the City Corporation of Panaji	Member, Ex-Officio
7.	"Regional Railway Manager", Konkan Railway Corporation Limited	Member
8.	Dattaram Balekar, R/o, Rith Builders Residency, Cabesao St. Cruz Tiswadi Goa	Member
9.	Devidas Malik, R/o, Upper Harvalem Sankhalim Goa.	Member
10.	Megha Perreira, Calapur Bandh Santa Cruz Tiswadi Goa.	Member
11.	Bassawa Ellanur, R/o, Camrabhatt Tonca Tiswadi Goa.	Member
12.	SBI Lead Bank Manager (North Goa)	Member
13.	Director of Social Welfare, Panaji	Member-Secretary

South Goa District

1.	District Magistrate & Collector, South, Goa.	Chairperson, Ex-Officio
2.	Shri Manohar Azgaonkar Members Of Legislative Assembly (SC)	Member, Ex-Officio
3.	Superintendent of Police (South, Goa)	Member, Ex-Officio
4.	Director of Panchayat	Member, Ex-Officio
5.	Director of Municipal Administration	Member, Ex-Officio
6.	Chief Officer, Margao Municipal Council	Member

7.	"Regional Railway Manager", Konkan Railway Corporation Limited	Member
8.	Anil G Pavaskar, H.No. 35, Kantem Baina, kaulhonkar Chawl, Vasco Da Game Goa.	Member
9.	Vishal Naik, c/o, Cuncolim Municipal Council, Cuncolim Salcete Goa.	Member
10.	Anumava H Harijan, Nr. Rashtroli Temple, Room No. 7, Housing Board Colony, New Vaddem Vasco Goa.	Member
11.	Priya Velip, c/o, Cuncolim Municipal Council, Cuncolim Salcete Goa.	Member
12.	SBI Lead Bank Manager (South Goa)	Member
13.	Director of Social Welfare, Panaji	Member-Secretary

The Vigilance Committee shall meet every six months.

By order and in the name of
the Governor of Goa

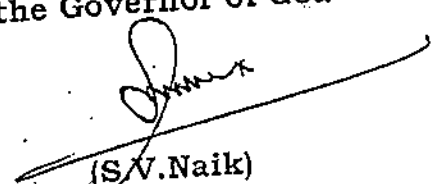
(S.V. Naik)
Director of Social Welfare &
Ex-Officio Adl. Secretary (SW)

Copy to:-

1. The Director, Government Printing Press, Panaji for favor of Publication in the Official Gazette in the next issue and supply of five copies of the same to this office for records.
2. All the above mentioned Members.
3. All Heads of Departments/Offices
4. Guard File
5. Office Copy.

//True copy//

Regd AD.



GOVERNMENT OF GOA
DIRECTORATE OF SOCIAL WELFARE
18TH JUNE ROAD, PANAJI-GOA
Tel.No.2223784,2232257 Fax No. 2228172

No. 85-5-98-SD/Part/Vol.VI/6570

Dated: 8/12/2023

Ref : Our Office letter No 85-5-98-SD/Part/Vol.VI/5766
dt. 13/11/2023

NOTICE

Whereas you had requested this office vide letter dated 8/06/23 to give two months time to settle the remaining balance amount of compensation to the 2 grieving families of labourers in Sewer death case.

And Whereas as informed by you that the 3rd Labourer Shri Santosh Oli who's family is not traceable. In this regard this office is in receipt of Vigilance report dated 20/11/2023 wherein wife of the deceased has been informed to contact the Panaji Police Station for further details.

Whereas vide this office letter dated 13/11/2023 it was requested to submit payment status of remaining balance compensation as the time limit requested by you has lapsed.

And whereas now the Hon'ble Supreme Court vide Judgement dated 20/10/2023 in Writ Petition Civil No (s). 324 of 2020 (copy enclosed) para 96 (4) has directed the Union and the States to ensure that the compensation for sewer deaths is increased (given that the previous amount fixed, i.e., 10 lakhs) was made applicable from 1993. The current equivalent Rs of that amount is Rs. 30 lakhs. This shall be the amount to be paid, by the concerned agency, i.e., the Union, the Union Territory or the State as the case may be. In other words, compensation for sewer deaths shall be Rs 30 lakhs. In the event, dependents of any victim have not been paid such amount, the above amount shall be payable to

them. Furthermore, this shall be the amount to be hereafter paid, as compensation.

You are hereby notified regarding the above direction issued by the Hon'ble Supreme Court and directed to pay the balance compensation amounting to Rs. 30 Lakhs each to the dependants of the 3 victim who have not been paid till date. You are further directed to pay the compensation amount within 15 days failing which the amount will be recovered as per the Goa Daman and Diu Land Revenue Code , 1968, without any further notice whatsoever.

Please treat this as final.



(Ajit Panchwadkar)
Director of Social Welfare &
Ex-Officio Addl. Secretary (SW)

To,
The Proprietor,
Shell Top Inn, NH-17, St Cruz,
Panaji- Goa.

Copy to :

1. The Secretary(IAS), National Commission for Safai Karmacharies, Ministry of Social Justice and Empowerment, B Wing 4th Floor, Lok Nayak Bhawan, Khan Market, New Delhi.
2. P.A to Secretary (SW), Secretariat, Porvorim- Goa for information.
3. The District Magistrate/ Collector North, Panaji- Goa.
4. Guard File
5. Office copy

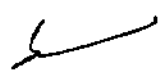
//True copy//



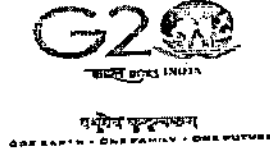

Annexure IV-B

No.SJED/GSK/e-file/17/2023/0906/G
Social Justice and Empowerment Department,
Government of Gujarat,
Gandhinagar.
Date:16/12/2023

To
Deputy Secretary,
Ministry of Social Justice and Empowerment,
B-2, Ground Floor, Pandit Deendayal Antyodaya Bhawan,
CGO Complex,
New Delhi-110003

Subject: Regarding Writ Petition No.324/2020 Dr.Balramsingh Vs Union of India and Ors.

Respected Sir,

In reference to your letter dated:14/11/2023 regarding aforementioned subject, It was requested to provide information regarding implementation of Hon'ble Supreme court's order dated 20/10/2023 in Writ Petition No.324/2020 Dr.Balramsingh Vs Union of India and Ors. The said information is attached herewith.

Regards.

Yours faithfully,

eSign
Signed by: JIGAR GJUBHAI PATEL
Organization Unit: Social Justice and
Empowerment Department
Organization Name: GOVERNMENT
OF GUJARAT
Date: 18-Dec-2023 (03:08 PM)

(Jigar Patel)
Deputy Secretary
Social Justice and Empowerment Department
Government of Gujarat

//True copy//

Sr.No	GOI Points	Remarks
1	MS Act, 2013; MS Rules 2013 and guidelines framed by the Union are embodied in States/ UTS guidelines and directions are applicable to all municipalities and local bodies [para 96 (2)];	<p>For effective implementation of MS Act, 2013 and MS Rules 2013 directions are given to local bodies vide Government Resolutions, circulars and letters as mentioned below.</p> <p>GR dated 21/06/2014 of Panchayat rural housing and Rural Development,</p> <p>GR dated 16/12/2016 of Urban development and urban housing development department,</p> <p>Circular Dated 10/05/2019 of Urban development and urban housing development department,</p> <p>Circular Dated 11/07/2019 of Panchayat rural housing and Rural Development</p> <p>GR dated 28/04/2021 of Urban development and urban housing development department,</p> <p>Circular Dated 06/09/2023 of Urban development and urban housing development department,</p> <p>Letter dated:30/10/2023 of Urban development and urban housing development department,</p>
2	Full rehabilitation (including employment to the next of kin, education to the wards, and skill training) of sewage workers, and those who die [para 96 (3)];	<p>Urban development and urban housing development department has approved guidelines regarding appointment of the next of kin of the person who dies on duty or who suffers incapacitating injury on duty vide GR dated 18/10/2017.</p> <p>The Municipal Corporations of the State, as per their respective policies, appoints the next of kin of the person who dies on duty.</p> <p>Skill development programs are organized in the state for capacity building and skill upgradation.</p> <p>Health check up for Safai Karmcharis is organized on regular intervals.</p>

//True copy//

		<p>In Vadodara Municipal Corporation all Safai Karmacharis ,retired workers and their family members are provided health facilities though "Medical Card". In Vadodara Municipal Corporation children of Safai karmcharis are provided free books on annual basis.</p> <p>Gujarat Safai Kamdar Vikas Nigam is implementing educational, economical, residential and social security related schemes for upliftment and rehabilitation of Safai Karmcharis and their dependents.</p>
3	<p>Payment of compensation with increased amount i.e., 30 lakhs for sewer deaths. In of any victim have not been paid snch amount, the above the event, dependents amount shall be payable to them, hereafter as compensation [para 96 (4)];</p>	<p>Social Justice and Empowerment department has directed Urban development and urban housing development department And Panchayat rural housing and rural development department to implement Hon. Supreme court's order dated:20/10/2023.</p> <p>These respective departments have passed on the said instructions to the local bodies under their purview.</p> <p>In Gujarat, the compensation of rs.30 lakhs is being paid to the legal heirs of the deceased in sewer death in each case as per Hon'ble Supreme court's judgment dated 20/10/2023</p>
4	<p>Devise suitable mechanism to ensure accountability, especially wherever sewer deaths occur in the course of contractual or "outsoureed" work [para 96 (6)];</p>	<p>Manual scavenging is prohibited in the state of Gujarat.</p> <p>Urban development and urban housing development department, vide its circular dated:10/05/2019, has fixed accountability of contractors when the work is outsourced.</p> <p>Panchayat rural housing and Rural Development Department, vide its GR dated:10/10/2014 has fixed accountability of contractors when the work is outsourced.</p>
5	<p>Set up scholarships to ensure that the dependents of sewer victims, (who have died. or might have suffered disabilities) are given meaningful education [para 96 (10)];</p>	<p>Gujarat Safai Kamdar Vikas Nigam is implementing scholarship seheme for the children of the persons who engage in unclean profession.</p>

//True copy//

6	<p>Ensure establishment of State Commission for Safai Karmacharis and all Committees mentioned in MS Act, 2013 and MS Rules 2013 including State Monitoring Committee, State Level Survey Committee, District Vigilance Committee and District Level Survey Committee by 30.11.2023 [para 96 (12)].</p>	<p>Constitution of state level commission for Safai Karmachari or designation of any other authority to look after the work of state level Safai Karmachari Commission is under active consideration at the highest level of the state Government.</p> <p>State level Monitoring committee has been constituted vide Social Justice and Empower Department's GR dated 01/04/2015</p> <p>Division and Subdivision level vigilance committees have been formed vide Social Justice and Empower Department's GR dated 01/03/2016</p>
7	<p>It is therefore requested that necessary action may be taken immediately in compliance of observations of Hon'ble Supreme Court. Necessary guidelines for implementation of survey etc. are being finalized and will be issued shortly. It is requested that Principal Secretary / Secretary, Social Welfare dealing with SafaiKaramcharis may be nominated as Nodal Officer for the ease and his/her details may be provided immediately through email id srivastwa.sk@nic.in / manojk.jha@nic.in. The status of implementation of the judgement of the Hon'ble Supreme Court may be sent by 31.12.2023 so that status could be filed before the Court.</p>	<p>Social Justice and Empowerment department has directed Urban development and urban housing development department And Panchayat rural housing and rural development department to implement Hon. Supreme court's order dated:20/10/2023.</p> <p>These respective departments have passed on the said instructions to the local bodies under their purview.</p> <p>Depnty Secretary (Social Caste Welfare) is nominated as Nodal officer in this matter, whose details are as given below.</p> <p>Name: Jigar Patel</p> <p>Designation: Deputy Secretary (Social Caste Welfare)</p> <p>Address: Block no 5, 9th floor, Social Jnstice and Empowerment Department, Saehivalay, Sector 10B, Gandhinagar</p> <p>Phone no: 07923251206</p> <p>Email id: ds-scw-sje@gujarat.gov.in</p>

//True copy//

✓

Annexure - IV - C

E-maw
Supreme Court Matter

(9)

From No. SJE-B-E05/1/2023-SJE
Government of Himachal Pradesh,
Department of Social Justice & Empowerment-B

To Secretary (SJ&E) to the
Government of H.P. Shimla-2.

Sh. S.K. Srivastwa,
Deputy Secretary, Govt. of India,
Ministry of SJ&E, Department of Social Justice &
Empowerment, B-2, Ground Floor, Pt. Deendayal Antyodaya
Bhawan, CGO Complex, New Delhi-110003.

Dated Shimla-2, the 30th December, 2023.

Subject: - Civil Writ Petition (PIL) NO. 324 of 2020 in the matter of Dr.
Balaran Singh V/s Union of India and other pending Before
Supreme Court of India.

Sir,

I am directed to refer to your letter No. U-12012/01/2023 (Plan).
dated 15.12.2023 and subsequent reminder letter of even Number dated 18.12.2023 on
the subject cited above and to say that the pointwise Action Taken Report on the
observation made by the Hon'ble Supreme Court on dated 20-10-2023 is enclosed
herewith for further necessary action at your end please.

Yours faithfully,

(Jeewan Singh)

Joint Secretary (SJ&E) to the
Government of Himachal Pradesh
PIL. No. 0177-2880659

Enclosures: As Above.

//True copy//

Action Taken Report on the observation made by the Hon'ble Supreme Court in CWPIL NO. 324/2020 in the matter of Dr. Balaram Singh Vs Union of India and ors.

Sr. No.	Observation made by the Hon'ble Supreme Court.	Compliance Report
1.	MS Act, 2013; MS Rules 2013 and guidelines framed by the Union are embodied in States/UTs guidelines and directions are applicable to all municipalities and local bodies [para 96 (2)]	In this regard, all the Urban Local Bodies and the District Collectors have been directed from time to time to go through the provision of Manual Scavengers and their Rehabilitation Act, 2013 and take further necessary action as per provision of the Act.
2.	Full rehabilitation (including employment to the next of kin, education to the wards, and skill training) of sewage workers, and those who die [para 96(3)]	Under National Urban Livelihood Mission (NULM) scheme namely Employment through Skill Training & Placement (EST&P) component, there is provision for training, skills improvement to the unskilled urban poor as well as to upgrade their existing skills. The programme will provide for skill training of the urban poor to enable them setting up self-employment ventures and for salaried jobs in the private sector.
3.	Payment of compensation with increased amount i.e., ₹ 30 lakhs for sewer deaths, in the event, dependents of any victim have not been paid such amount, the above amount shall be payable to them, hereafter as compensation [para 96(4)]	There is no such case in the urban areas of H.P where death of worker happened due to sewer cleaning.
4.	Payment of compensation of Rs. 20 lakhs, in the case of sewer victims suffering disabilities, depending upon the severity of disabilities, Minimum	There is no such case in the urban areas of H.P where death of worker happened due to sewer cleaning.

//True copy//
42

	compensation shall not be less than ₹ 10 lakhs [para 96(5)]	
5.	Devise suitable mechanism to ensure accountability, especially wherever sewer deaths occur in the course of contractual or "outsourced" work [para 96(6)]	In order to prevent the sewer death occurred in the course of contractual of outsourced work, all the ULBS have already been directed to incorporate a clause in the agreement with contractor that the provision of the Manual Scavengers and their Rehabilitation Act, 2013 shall be applicable. Employers/ Contractor should be made responsible for every case of sewer death.
6.	Set up scholarships to ensure that the dependents of sewer victims, (who have died, or might have suffered disabilities) are given meaningful education [para 96(10)]	The Department of Education has been directed to frame scholarship scheme to such dependent of sewer victims. Whereas, The Department of Education is implementing Maharishi Balmiki Chattarvriti Yojana (100% SSS) in the state and under this scheme an amount of @ ₹ 18000/- per year is given to the Bonafide residents of all Himachali girl students belonging to Balmiki Families, engaged in unclean occupation, beyond Matric to college level for studies and professional course at the level of colleges situated in Himachal Pradesh. It is further submitted that the Department of SJ&E is providing scholarship to the students with disabilities upto 5000/- per month with out considering their family income from class I to post graduate level.
7.	Ensure establishment of State Commission for Safai Karmacharis and all Committees mentioned in MS Act. 2013 and	In the State of Himachal Pradesh, State Commission for Safai Karmchhari has not been notified. Whereas, Director Empowerment

//True copy//

	<p>MS Rules 2013 including State Monitoring Committee, State Level Survey Committee, District Vigilance Committee and District Level Survey Committee by 30.11.2023[para 96(12)];</p>	<p>of SCs, OBCs, Minorities & Specially Abled (ESOMSA) has been designated authority to perform the function specified in sub section (1) of section 31 of the Manual Scavengers and their Rehabilitation Act, 2013. The Himachal Pradesh State Commission for Scheduled Castes has been designated to look after the work of State Level Commission for Safai Karamcharis. For effective implementation of the Manual Scavengers and their Rehabilitation Act and Rules in right prospective, State Level Monitoring Committee, District level Vigilance Committee, have been constituted. Director Empowerment of SCs, OBCs, Minorities & Specially Abled has been nominated Nodal Officer for the purpose of identification of scavenger engaged in insanitary latrines and their rehabilitation. The copy of notifications are enclosed.</p>
--	---------------------------------------------------------------------------------------------------------------------------------------------------------------------------------------	----------------------------------------------------------------------------------------------------------------------------------------------------------------------------------------------------------------------------------------------------------------------------------------------------------------------------------------------------------------------------------------------------------------------------------------------------------------------------------------------------------------------------------------------------------------------------------------------------------------------------------------------------------------------------------------------------------------------------------------------------------------------------------------------------------------------------------------------------------

//True copy// ✓

Government of Himachal Pradesh
Social Justice & Empowerment Department
(Section-B)

No.SJE-B-F-(1)-9/2014

Dated Shimla-17/02.18 4-10-2014

NOTIFICATION

In exercise of the powers conferred in Section 26 (1) of the "Prohibition of Employment as Manual Scavenger and their Rehabilitation Act, 2013", the Governor, Himachal Pradesh is pleased to constitute a State Monitoring Committee consisting of the following members in order to implement the provisions of the Act in its rights perspective:-

Sr.No.	Name	Designation
1.	Social Justice & Empowerment Minister	Chairman
2.	Two member of State Legislature belonging to the Scheduled Castes	(To be nominated)
3.	ACS/Principal Secretary (Home) to the Government of Himachal Pradesh	Member
4.	ACS/Principal Secretary (Panchayati Raj) to the Government of Himachal Pradesh	Member
5.	ACS/Principal Secretary (Urban Development) to the Government of Himachal Pradesh	Member
6.	ACS/Principal Secretary (Rural Development) to the Government of Himachal Pradesh	Member
7.	ACS/Principal Secretary (Finance) to the Government of Himachal Pradesh	Member
8.	ACS/Principal Secretary (SJ&E) to the Government of Himachal Pradesh	Member
9.	Director General of Police, Himachal Pradesh	Member
10.	Commissioner, Municipal Corporation, Shimla	Member
11.	District Level Cantonment Board and Railway Authority	Member (To be nominated)
12.	Four Social Workers working for the Rehabilitation of Manual Scavengers/Scavenger Community/Resident in the State Two of whom shall be women.	Member (To be nominated)

//True copy//

Red-up for perusal Working Dir.

Annexure - 'A' 89

Government of Himachal Pradesh
Department of Social Justice and Empowerment
Section-B

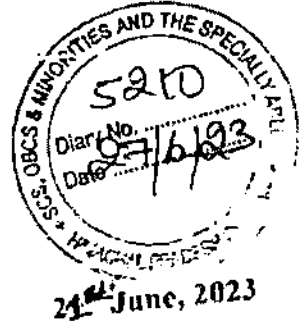

2234

No. SJE-B(A)-14/2013

Dated: Shimla-171002, the

NOTIFICATION

In exercise of the powers conferred by Section 32 of "The Prohibition of Employment as Manual Scavengers and Their Rehabilitation Act, 2013", the Governor, Himachal Pradesh is pleased to designate Himachal Pradesh State Commission for Scheduled Castes to look after the work of State Level Commission for Safai Karamcharis with immediate effect.

By order,
M. Sudha Devi
Secretary (SJ&E) to the
Government of Himachal Pradesh
21 June, 2023

Endorsement No: As Above.

Dated: Shimla-171002,

Copy forwarded to the following for information and necessary action please:-

1. All the Principal Advisor to the Government of H.P., Shimla -02.
2. The Secretary, Government of India, National Commission for Safai Karamcharis, Ministry of Social Justice & Empowerment, 'B' Wing, 4th Floor, Lok Nayak Bhawan, Khan Market, New Delhi- 110003.
3. All the Administrative Secretaries to the Government of H.P., Shimla-02.
4. The Principal Secretary to the Chief Minister, H.P., Shimla-02.
5. The Secretary to Governor, Himachal Pradesh, Shimla-02.
6. All the Heads of Department in Himachal Pradesh.
7. All the Divisional Commissioner/ Deputy Commissioner, H.P.
8. The Director, Empowerment of SCs, OBCs, Minority & Specially Abled, Himachal Pradesh.
9. The Member Secretary (Director, ESOMSA), HP State Commission for Scheduled Castes, Kasumpti, Shimla.
10. The Controller, Printing & Stationery Department, Shimla-5 for publication in the Rajprtra/e-Gazette of Himachal Pradesh and requested to supply the one copy of Rajprtra to this Department for record.
11. All the Pr./Spl./Sr. Spl./Sr./Private Secretaries to the Chief Minsiter/ Minister/Chief Parliamentary Secretary, Himachal Pradesh, Shimla 02.
12. The Sr. Spl. Private Secretary to Chief Secretary to the Government of H.P., Shimla -02.
13. Guard file.

21.6.23
(Jeevan Singh)

Joint Secretary (SJ&E) to the
Government of Himachal Pradesh
Phone No. 0177-2880659

//True copy//

Government of Himachal Pradesh
Social Justice & Empowerment Department
(Section-B)

— 17/ —

By No. 7285

4/9/2014

No.SJE-B-F-(1)-9/2014

Dated Shimla-171002.the 30th August, 2014

NOTIFICATION

In exercise of the powers conferred in Sub-Section (1) and (2) of Section 24 of the "Prohibition of Employment as Manual Scavenger and their Rehabilitation Act, 2013", the Governor, Himachal Pradesh is pleased to constitute a District Level Vigilance Committee consisting of the following members in order to implement the provisions of the Act:-

Sr.No.	Name	Designation
1.	District Magistrate	Chairman
2.	All member of State Legislature belonging to the Scheduled Castes elected from the District	Members
3.	District Superintendent of Police	Member
4.	Chairperson, Zila Parishad	Member
5.	Chairperson of the Municipality of District Head	Member
6.	Representative of Cantonment Board, if any situated in the District	Member
7.	One representative to be nominated by the Railway Authority located in the District	Member
8.	Four Social Workers working for the Prohibition of Manual Scavenging and rehabilitation of Manual Scavenger (Two of whom shall be women).	Member (to be nominated by District Magistrate)
9.	One person to represent the Financial and Credit Institution in the District	Member (to be nominated by District Magistrate)
10.	District Welfare Officer.	Member Secretary

By order

P.C. Dhinan

Principal Secretary (SJ&E) to the
Government of Himachal Pradesh.

//True copy//

-2/-

47

✓

Endst. No. as above Dated Shimla-171002, the

30th August, 2014.

Copy to the following for information and necessary action:-

1. Sh. Sudhir Bhargava. Secretary, GOI, Ministry of Social Justice & Empowerment, Shastri Bhawan, New Delhi-110001 for information with reference to his D.O. Letter No.19016/54/2014-SCD-IV dated 14-7-2014.
2. The Chief Secretary, Himachal Pradesh, Shimla-171002.
3. All the Additional Chief Secretaries to the Government of H.P. Shimla-2.
4. All the Pr. Secretaries/Secretaries to the Government of H.P. Shimla-2.
5. The Principal Secretary to the Hon'ble Chief Minister, H.P. Shimla-2.
6. The Special Secretary-cum-Pr. Private Secretary to the Hon'ble Chief Minister, Himachal Pradesh, Shimla-171002.
7. The Secretary to the Governor, Himachal Pradesh, Shimla-171002.
8. The Principal Accountant General (A&E)/Accountant General (Audit), H.P, Shimla - 171003.
9. All the Divisional Commissioners/HODs/DCs in Himachal Pradesh.
10. The Director, SCs, OBCs and Minority Affairs, HP, SDA Complex, Kasumpti, Shimla - 171009
11. The Controller, Printing & Stationery Press, HP Govt. Printing Press, Shimla-5
12. All Private Secretaries of the Ministers/CPS in H.P. Secretariat Shimla-2.
13. Guard file/Spare copies (25).

Uttar

Joint Secretary (SJ&E) to the
Government of Himachal Pradesh.

//True copy//

✓

Government of Himachal Pradesh
Social Justice & Empowerment Department
(Section-B)

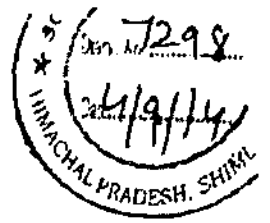

No.SJE-B-F-(1)-9/2014

Dated Shimla-171002.the 30th August, 2014

NOTIFICATION

In exercise of the powers conferred in the "Prohibition of Employment as Manual Scavenger and their Rehabilitation Act, 2013", the Governor, Himachal Pradesh is pleased to nominate the Director, SCs, OBCs and Minority Affairs, Himachal Pradesh as "Nodal Officer" for the purpose of identification of scavenger engaged in insanitary latrines and their rehabilitation.

By order

P.C. Dhiman
Principal Secretary (SJ&E) to the
Government of Himachal Pradesh.

Endst. No. as above Dated Shimla-171002, the

30th August, 2014.

Copy to the following for information and necessary action:-

1. Sh Sudhir Bhargava, Secretary, GOI, Ministry of Social Justice & Empowerment, Shastri Bhawan, New Delhi-110001 for information with reference to his D.O. letter No:19016/54/2014-SCD-IV dated 14-7-2014.
2. The Principal Secretary (UD) to the Government of Himachal Pradesh.
3. The Principal Secretary (RD) to the Government of Himachal Pradesh.
4. The Director, Urban Development, Talland, Shimla-1
5. The Director, Rural Development, B-27, SDA Complex, Shimla-9
6. The Managing Director, HP SC/ST Corporation, Kalyan Bhawan, near Kalyan Bhawan, Solan, H.P.
7. Guard file.

Uday
Joint Secretary (SJ&E) to the
Government of Himachal Pradesh.

//True copy//



Register Post

Social Welfare Department

Karnataka State Commission for Safai Karmacharis

NO.1/14, South wing Ground floor, Silver jubilee block part of Unity Building Complex, Mission Road, Bangalore-27,
Telephone: 080-22240445/6, Email: ksskcb@gmail.com

No: KSSKCB/SC/WP-324-2020/ 2022-23,

Date: 27.12.2023

The Deputy Secretary,
Government of India,
Ministry of Social Justice & Empowerment,
Room No.604, 'A' Wing,
New Delhi-110 001.

Respected Sir,

Sub: Providing information to Case No.WP(Civil) No.324 of 2020
(Dr.Balram Singh Vs Union of India &Ors) and others.

Ref: Video Conference, Dated: 15.12.2023

With reference to the above Subject in Video Conference dated: 15.12.2023, it was directed to submit the updated information as per Hon'ble Supreme Court WP No.324/2020 Judgment Para 96 (1) to (14).

As per the Judgment Para 96 (4) & (5) it is necessary to revise the present compensation from "Rs.10.00 lakhs to Rs.30.00 lakhs to the dependents of workers who died while working in manholes, septic tanks, sewers and open drains in the State, and the minimum compensation should not be less than Rs.10.00 lakhs depending on the severity of disability of the victim and if the disability is permanent and renders the victim financially helpless to distribute the compensation not less than Rs.20.00 lakhs ,In respect to this in letter dated :22.11.2023 letter has been communicated by Principal Secretary ,Social Welfare Department to the Heads of Urban Development Department and Rural Deveopment and Panchayat Raj Department to issue/pass an order as per Hon'ble Supreme Court WP No.324/2020 Judgment Para 96 (4) & (5), and the order copy will be sent as soon as possible.

Further the latest information of other points of judgment is enclosed with this letter for further necessary action.

Yours faithfully

Chandrabala.
Secretary, 27-12-2023

Karnataka State Commission for
Safai Karmachari's, Bangalore.

//True copy//

Proforma

Name of State: KARNATAKA

Sl. No.	Name of Institutions	Date of constitution or designating	Name of Commission/ Agency designated to act as Commission	If not, reasons thereof
1.	Constitution of State Safai Karamcharis Commission/ Designating an Agency to work as State Safai Karamcharis Commission [Section 32 of MS Act, 2013]	03.01.2013	State Commission for Safai Karmachari's (Annexure-I) (Annexure-IA)	

Sl. No.	Name of Institutions	Date of constitution	Date of last meeting	If not constituted, reasons thereof
2.	State Monitoring Committee (Section 26 of MS Act, 2013)	03.05.2014	22.09.2023 (Minutes of the Meeting Enclosed Annexure-II)	
3.	District Vigilance Committee [Section 24 (2) of MS Act 2013]	Details Enclosed in Annexure-III		
4.	Sub-Division Vigilance Committee [Section 24 (3) of MS Act 2013]	Details Enclosed in (Annexure-IV)		
5.	State Level Survey Committee (Rule 2-j of MS Rules 2013)	05.02.2021	23.02.2023 (Annexure-V)	
6.	District level survey committee (Rule 2-c of MS Rules 2013)	Details Enclosed in (Annexure-VI)		

7. Details of all prosecutions initiated for manual scavenging and insanitary latrines ever since the 2013 Act came into force, alongwith details of the exact stage of each prosecution.

Sl. No.	District	Name of the offender	Name of Manual Scavengers	Date of occurrence	FIR No/Date and Sections	Current status of investigation/Prosecution
Details Enclosed in (Annexure-VII)						

True copy
2023/05/21

8. The number of sewer deaths that have taken place since the 2013 Act came into force, along with details of prosecution in respect of each of these deaths, along with the names of each victim and the compensation paid to each of their families.

Sl. No.	District	Name of the deceased	Date of Death	FIR No/Date and Sections	Name(s) of Accused	Current status of investigation/ Prosecution	Amount of compensation paid	Date of payment
Details Enclosed in (Annexure-VIII)								

9. OTHER REHABILITATION BENEFITS EXTENDED TO IDENTIFIED MANUAL SCAVENGERS:

Sl. No.	Name of the scheme of State	Benefit provided	Name of the Manual Scavenger	Date of benefit provided	Remarks
Details Enclosed in (Annexure-IX)					

॥॥॥॥॥॥॥॥

True copy

Annexure-I

Name of State: KARNATAKA

Sl. No.	Name of Institutions	Date of constitution or designating	Name of Commission/ Agency designated to act as Commission	If not, reasons thereof
1.	Constitution of State Safai Karamcharis Commission/ Designating an Agency to work as State Safai Karamcharis Commission [Section 32 of MS Act, 2013]	03.01.2013	State Commission for Safai Karmachari's	

//True copy//

True copy // 54

- (5) "Safal Karmachari" means a person engaged in, or employed for, manually carrying human excreta or any sanitation work;
 - (4) "prescribed" means prescribed by rules made under this Act;
 - (3) "Member" means a Member of the Commission;
 - (2) "Commission" means the Karnataka State Commission for Safal Karmacharis;
 - (1) "Chairperson" means the Chairperson of the Karnataka State Commission for Safal Karmacharis;
2. Definitions. In this Act, unless the context otherwise requires:-
- (1) This Act may be called the Karnataka State Commission for Safal Karmacharis Act, 2012.
- (2) It shall come into force on such date as the State Government may, by notification, appoint.
1. Short title and commencement.- (1) This Act may be called the Karnataka State Commission for Safal Karmacharis Act, 2012.

PRELIMINARY
CHAPTER - 1

as follows:-

Be it enacted by Karnataka State Legislature in the Sixty third year of the Republic of India

matters connected therewith or incidental thereto:

Whereas it is expedient to constitute a Commission for the Safal Karmacharis and for

An Act to constitute the Karnataka State Commission for Safal Karmacharis.

(Received the assent of the Governor on the third day of January, 2013)

THE KARNATAKA STATE COMMISSION FOR SAFAL KARMACHARIS ACT, 2012

(First published in the Karnataka Gazette Extra-ordinary on the fourth day of January, 2013)

KARNATAKA ACT NO. 2 OF 2013

348 of the Constitution of India

Official Gazette under the authority of the Governor of Karnataka under clause (3) of Article

2012 (2013ರ ಕರ್ನಾಟಕ ಸಂಖ್ಯೆ: 2) ಇಂಗ್ಲಿಷ್ ಭಾಷೆಯಲ್ಲಿ ಪ್ರಕಟವಾಗಿದೆ.

The following translation of the ಕರ್ನಾಟಕ ರಾಜ್ಯ ಸಂಖ್ಯೆ: 2013ರ ಕರ್ನಾಟಕ ಸಂಖ್ಯೆ: 2012ರ ಕರ್ನಾಟಕ ಸಂಖ್ಯೆ: 2012 (2013ರ ಕರ್ನಾಟಕ ಸಂಖ್ಯೆ: 2) ಇಂಗ್ಲಿಷ್ ಭಾಷೆಯಲ್ಲಿ ಪ್ರಕಟವಾಗಿದೆ.

Karnataka Gazette for general information.

the Governor of Karnataka under clause (3) of Article 348 of the constitution of India in the

2012 (2013ರ ಕರ್ನಾಟಕ ಸಂಖ್ಯೆ: 2) ಇಂಗ್ಲಿಷ್ ಭಾಷೆಯಲ್ಲಿ ಪ್ರಕಟವಾಗಿದೆ.

Ordered that the translation of the ಕರ್ನಾಟಕ ರಾಜ್ಯ ಸಂಖ್ಯೆ: 2013ರ ಕರ್ನಾಟಕ ಸಂಖ್ಯೆ: 2012 (2013ರ ಕರ್ನಾಟಕ ಸಂಖ್ಯೆ: 2) ಇಂಗ್ಲಿಷ್ ಭಾಷೆಯಲ್ಲಿ ಪ್ರಕಟವಾಗಿದೆ.

No. SAMVYASHAB 50 SHASANA 2012, Bangalore, Dated : 29.01.2013

NOTIFICATION

PARLIAMENTARY AFFAIRS AND LEGISLATION SECRETARIAT

Part - IV-A	ಬೆಂಗಳೂರು, ದಿನಾಂಕ: 29.01.2013 (ಶುಕ್ರವಾರ, 29.01.2013)	ನಂ. 83
Part - IV-A	Bangalore, Tuesday, January 29, 2013 (Magha 9, Shaka Varsaha 1934)	No. 83

ದಿನಾಂಕ: 29.01.2013

ಅಧಿಕಾರ ವಹಿಸಲಾಯಿತು

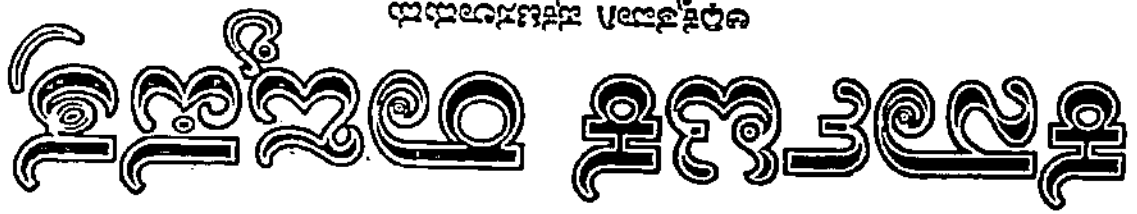

KNT No. KARBH/2001/47147

Annexure-1

CHAPTER - II

STATE COMMISSION FOR SAFAI KARMACHARIS

3. Constitution of the Commission.- (1) The State Government shall, by notification in the Official Gazette, constitute a Commission to be known as the Karnataka State Commission for Safai Karmacharis to exercise the powers conferred on, and to perform the functions assigned to it under this Act consisting of the following, namely:-

- (i) A Chairperson to be nominated by State Government who in its opinion is a person having knowledge and associated with the socio-economic development and welfare of Safai Karmacharis;
- (ii) Two members out of whom one shall be a women to be nominated by the State Government who in its opinion is a person having knowledge and associated with the socio-economic development and welfare of Safai Karmacharis.

(2) The Head quarters of the Commission shall be at Bangalore.

4. Term of office and conditions of service of the Chairperson and Member.- (1) Subject to the pleasure of the State Government, the Chairperson and every Member shall hold office for such period not exceeding three years as may be specified by the State Government in this behalf.

(2) The Chairperson or a Member may, at any time by giving notice in writing under his signature, addressed to the State Government, resign from the office of the Chairperson or the Member, as the case may be.

(3) The State Government may by order, remove from office, the Chairperson or any Member if the chairperson or such member, as the case may be,-

- (a) becomes an un discharged insolvent; or
- (b) is convicted and sentenced to imprisonment for an offence which, in the opinion of the State Government, involves moral turpitude; or
- (c) is of unsound mind and stands so declared by a competent court of law; or
- (d) refuses to act or becomes incapable of so acting; or
- (e) without obtaining leave, absents himself from the commission or absents from three consecutive meetings of the commission; or
- (f) in the opinion of the State Government has so abused the position of Chairperson or Member so as to render that person's continuance in office detrimental to the interest of Safai Karmacharis in the public interest;

Provided that no person shall be so removed under this clause unless that person has been given a reasonable opportunity of being heard in the matter.

(4) A vacancy caused under sub-section (2) or otherwise, shall be filled by fresh nomination by the State Government.

(5) The salaries and allowances payable to and other terms and conditions of service of the Chairperson, and Members shall be such as may be prescribed.

5. Staff of the Commission.- The State Government shall provide the Commission with such officers and employees who are Government Servants as may be required for the proper functioning of the Commission under this Act. The strength and terms and conditions of the Officers and the employees of the Commission shall be such as may be prescribed.

6. Vacancy, etc., not to invalidate the proceedings of the Commission.- No act or proceeding of the Commission shall be questioned or shall be invalid merely on the ground of the existence of any vacancy or defect in the constitution of the commission.

7. Procedure to be regulated by the Commission.- (1) The Commission shall meet at such time and place as the Chairperson may think fit.

(2) Subject to the provisions of this Act and the rules made thereunder, the commission shall have the power to regulate its own procedure.

(3) All orders and decisions of the Commission shall be authenticated by the Chairperson or any other officer of the Commission duly authorised by the Chairperson in this behalf.

CHAPTER - III

FUNCTIONS AND POWERS OF THE COMMISSION

8. Functions of the Commission.-(i) The Commission shall perform all or any of the following functions, namely: -

- (a) recommend to the State Government specific programs of action towards elimination of inequalities in status, facilities and opportunities for Safai Karmacharis under a time-bound action plan;
- (b) to study and evaluate the implementation of the programs and schemes relating to the social and economic rehabilitation of Safai Karmacharis and make recommendations to the State Government for Co-ordination and implementation of such programs and schemes;

- (c) to enquire in to specific grievances and take notice of matters relating to non-implementation of,-
- (i) programs or schemes in respect of any group of Safai Karmacharis;
 - (ii) decisions, guidelines or instructions, aimed at mitigating the hardship of Safai Karmacharis;
 - (iii) measures for the social and economic upliftment of Safai Karmacharis;
 - (iv) the provisions of any law in its application to Safai Karmacharis and take up such matters with the concerned authorities.
- (d) to make periodical reports to the State Government on any matter relating to Safai Karmacharis, taking into account any difficulties or disabilities being encountered by Safai Karmacharis;
- (e) any other matter which may be referred to it by the State Government.
- (2) In the discharge of its functions under sub-section (1), the Commission shall have power to call for information with respect to any matter specified in that sub-section from State Government departments and its agencies/Corporations and local bodies.
- 9. Powers of the Commission.-** The Commission shall while investigating /enquiring any matter under section 8, have all the powers of civil court trying a suit under the code of civil procedure 1908, and in particular in respect of the following matters, namely:-
- (i) summoning and enforcing the attendance of any person from any part of the state and examining him on oath.
 - (ii) discovery and production of any documents and witness.
 - (iii) receiving any evidence on affidavits.
 - (iv) requisitioning for any public record or copy there of from any court or office.
 - (v) any other matter which may be prescribed.

CHAPTER - IV

FINANCE, ACCOUNTS AND AUDIT

10. Grants by the State Government.- (1) The State Government shall after due appropriation made by the State Legislature by law in this behalf, pay to the Commission by way of grants such sums of money as the State Government may think fit, for being utilized for the purposes of this Act.

(2) The Commission may spend such sums out of the grants as it thinks fit for performing the functions under this Act, and such sums shall be treated as expenditure payable out of the grants referred to in sub-section (1).

11. Accounts and audit.- (1) Accounts of income and expenditure of the Commission shall be kept in accordance with such rules, as may be prescribed.

(2) The Commission shall prepare an annual statement of accounts in such form as may be prescribed.

(3) The accounts of the Commission shall be audited annually by such auditor as the State Government may appoint.

(4) The auditor shall, for the purposes of audit have access to all the accounts and other records of the Commission.

(5) The Commission shall pay out of the grant such charges for the audit, as may be prescribed.

(6) As soon as after the receipt of the report from the auditor, the Commission shall send a copy of the annual statement of accounts, together with a copy of the report of the auditor to the State Government and shall cause to be published the annual statement of accounts in such manner as may be prescribed.

(7) After receipt of the audit report the State Government shall take necessary steps to lay the report before both houses of state Legislature.

(8) The State Government may, after perusal of the auditor report give such directions as it thinks fit to the Commission and the Commission shall comply with such directions.

CHAPTER - V

MISCELLANEOUS

12. Chairperson and Members and staff of the Commission to be the public servants.- The Chairperson, every Members, of the Commission and every officers appointed or authorized by the commission to exercise functions under this Act, shall be deemed to be public servants within the meaning of section 21 of the Indian Penal Code [Central Act 45 of 1860].

13. Annual Report.- The Commission shall prepare in such form and at such time for each financial year as may be prescribed its annual report giving a full account of its activities during the previous financial year and forward a copy thereof to the State Government.

11/10/00 8:11:11

14. **Annual report to be laid before State Legislature.**- The State Government shall cause the annual report to be laid before each House of State Legislature along with the memorandum explaining the action taken or proposed to be taken on the recommendations of the Commission and the reasons for non-acceptance of the recommendations, if any.

15. **Delegation of powers.** - The Commission may, by general or special order, delegate to the Chairperson or any Member or to any officer of the Commission subject to such conditions and limitations, if any as may be specified therein, such of its powers and duties under this Act as it may deem fit.

16. **Protection of action taken in good faith.** No suit, prosecution or other legal proceeding shall lie against the State Government, Commission, Chairperson, Members or any officer or other employee of the Commission for anything which is done in good faith or intended to be done under this Act.

17. **Power to make rules.**- (1) The State Government may, by notification in the Official Gazette, make rules to carry out the provisions of this Act.

(2) In particular, and without prejudice to the generality of the foregoing powers, such rules may provide for all or any of the following matters, namely:-

- (i) salaries and allowances payable to, and the other terms and conditions of service of, the Chairperson, and Members under sub-section (5) of section 4 and the officers and other employees of the Commission under section 5;
- (ii) the form in and the time at which the annual report shall be prepared under section 13.
- (iii) any other matter which is required to be, or as the case may be, to be made or prescribed.

(3) Every rule made under this Act shall be laid, as soon as may be after it is made, before both the House of State Legislature while it is in session for a total period of thirty days which may be comprised in one session or in two or more successive sessions, and if, before the expiry of the session immediately following the session or the successive sessions aforesaid, both Houses agree in making any modification in the rule or both Houses agree that the rule should not be made, the rule shall thereafter have effect only in such modified form or be of no effect, as the case may be; so, however, that any such modification or annulment shall be without prejudice to the validity of anything previously done under that rule.

18. **Power to remove difficulties.**- (1) If any difficulty arises in giving effect to the provisions of this Act, the State Government, may by order published in the official gazette make such provisions not inconsistent with the provisions of this Act as appear to it to be necessary or expedient for removing difficulty:

Provided that no such order shall be made after expiry of the period of two years from the date of commencement of this Act.

(2) Every order made under this section shall as soon as may be after it is made, be laid before both the houses of State Legislature.

The above translation of ಕರ್ನಾಟಕ ರಾಜ್ಯ ಸಭೆಯ ಕಾರ್ಯದರ್ಶಿ ಅಧಿನಿಯಮ, 2012 (2013ರ ಕರ್ನಾಟಕ ಅಧಿನಿಯಮ ಸಂಖ್ಯೆ: 2) be published in the Official Gazette under clause (3) of Article 348 of the Constitution of India.

H.R. BHARDWAJ
GOVERNOR OF KARNATAKA

By order and in the name of the Governor of Karnataka.

G.K. BOREGOWDA
Secretary to Government
Department of Parliamentary Affairs and Legislation



GOVERNMENT OF KARNATAKA

No.SWD 32 SDC 2017

Karnataka Government Secretariat
#229, 2nd Floor, Vikasa Soudha,
Bangalore, Dated: 03.04.2017

NOTIFICATION

In exercise of power of conferred under section 32(1) of the Prohibition of employment as manual scavengers and their rehabilitation Act 2013, the Government of Karnataka hereby notify that with effect from the date of publication of this notifications in official gazette, designate the Karnataka State Commission for Safai Karmacharis to perform within the state, mutatis mutandis, the functions specified in sub section(1) of section 31 and shall have specified in sub-section (1) of article 31 from any government or Local or other Authority.

By order and in the name of the
Governor of Karnataka

- Sd/-

(B.N. Sumathi)

Under Secretary to government
Social Welfare Department.

To

The Compiler, Karnataka Gazette, Bangalore for Publication in the next issue of the Gazette and for supply of 100 copies.

Copy to:

1. The Accountant General, Karnataka, Bangalore
2. The commissioner, Social Welfare Department, Bangalore
3. The Director, Tribal Welfare Department, Bangalore
4. Secretary to Government of India, Ministry of Social Justice Empowerment, New Delhi
5. Secretary to Government of India, Ministry of Urban Development New Delhi

//True copy//

Annexure-II

State Monitoring Committee (Section 26 of MS Act,2013)

Sl. No.	Name of Institutions	Date of constitution	Date of last meeting	If not constituted, reasons thereof
1.	State Monitoring Committee (Section 26 of MS Act, 2013)	03.05.2014	22.09.2023	-

//True copy//

Proceedings of the 6th Meeting of the "State Monitoring Committee" constituted under Section 26 of the Prohibition of Employment as Manual Scavengers and their Rehabilitation Act-2013 held on Date: 22-09-2023 under the Chairmanship of Hon'ble Minister of Social Welfare.

Attendees in the meeting:-

1. Dr|| HC Mahadevappa, Hon'ble Chairman and Minister, Department of Social Welfare, Bangalore.
2. Sri Priyank Kharge, Hon'ble Minister, Department of Rural Development and Panchayat Raj, Bangalore.
3. Shri K.S.Basavanhappa, Honorable MLA, Mayakonda Assembly Constituency.
4. Shri N. Srinivasa, Honorable MLA, Nelamangala Assembly Constituency.
5. Dr|| E. Venkataiah, Adviser, SCSP/TSP, Nodal Agency, Bangalore.
6. Principal Secretary to Government, Social Welfare Department, Bangalore.
7. Principal Secretary to Government, Labor Department, Bangalore.
8. Commissioner, Social Welfare Department, Bangalore.
9. Assistant Inspector General (AIG) Crime, Police Department, Bangalore on behalf of Director General and Inspector General of Police, Police Department.
10. Deputy Secretary to Government On behalf of Additional Chief Secretary to Government, Home Department (Administration), Bangalore.
11. Additional Chief Secretary to Government, Urban Development Department, Bangalore on behalf of Additional Chief Secretary to Government, Urban Development Department (BBMP).
12. Deputy Secretary to Government on behalf of Additional Chief Secretary to Government, Department of Finance, Bangalore.
13. Director, Family Welfare Department on behalf of the Principal Secretary to Government, Health and Family Welfare Department, Bangalore.
14. Under Secretary to Government, Revenue Department, Bangalore on behalf of Principal Secretary to Government, Revenue Department, Bangalore.
15. Deputy Secretary to Government, Urban Development Department, Bangalore.
16. Special Commissioner on behalf of the Chief Commissioner, Bruhat Bangalore Mahanagara Palike.
17. Chief Engineer, on behalf of the Chairman, Bangalore Water Supply and Sewerage Board, Bangalore.
18. Commissioner, Rural Drinking Water Supply and Sanitation Board Engineer, Rural Drinking Water Supply and Sanitation Board, Bangalore.
19. Director, Department of Prosecutions and Government Litigation, Bangalore.
20. Secretary, Karnataka State Commission for Safai Karmacharis, Bangalore.
21. Joint Director (administration) on behalf of the Director, Directorate of Municipal Administration, Bangalore.
22. Managing Director, Karnataka State Safai Karmachari Development Corporation, Bangalore.
23. Assistant Manager on behalf of the Managing Director, Rajiv Gandhi Housing Department, Bangalore.
24. Assistant General Manager, SLBC Section, LB&RRB Wing, Canara Bank.
25. Joint Secretary to Govt., Department of Women and Child Development, Bangalore.
26. Shri D.R.Raju, Nominated Member, State Level Monitoring Committee.
27. Dr. KB Obalesh, Nominated Member, State Level Monitoring Committee.
28. Smt. Padma, Nominee Member, State Level Monitoring Committee.
29. Smt. Narmada, Nominee Member, State Level Monitoring Committee.
30. Senior officers of various departments.

119905 51111
111119 111111
60

The Secretary, Karnataka State Safai Karmacharis Commission invited the Hon'ble Minister of Social Welfare Department and the Chairman of the State Monitoring Committee meeting, the members present in the meeting, nominated members, senior officers of various departments, and the meeting started with the permission of the Hon'ble Chairman.

The State Monitoring Committee under Section 26 of the Prohibition of Employment as Manual Scavengers and their Rehabilitation Act-2013 is a meeting conducted under the chairmanship of the Hon'ble Minister of Social Welfare and headed by the Minister of Urban Development and Minister of Rural Development and Panchayat Raj and including senior officials of various departments and nominated members. The problem of manual scavengers is an international problem and the presence of members like Deputy/Principal/Secretary of Rural Development and Urban Development Department is very important to take strict decisions about it, Urban and Rural Development Department, Chief Commissioner, BBMP to discuss the important points even though the information of the meeting is sent 12 days in advance with the notice of the meeting as per the rules of the committee. He expressed his displeasure over the absence of Officials & Honorable Minister and Chairman Directed the member Secretary to issue notice to the said officials to compulsorily attend the upcoming meetings and to take steps to compulsorily attend the meeting of the members directed in the committee.

Subject: 1. Details of action taken by various departments and compliance report on the proceedings of the 5th meeting of "State Monitoring Committee" held on 09-06-2022 were brought to the attention of the meeting and sought for approval.

Conclusion:

Action taken report of the proceedings of the 5th meeting of "State Monitoring Committee" held on Date: 09.06.2022 was approved.

Subject: 2. Out of total 7483 identified manual scavengers in the state, 2927 have been sanctioned One Time Cash Assistance (OTCA) by the Central Government and the remaining 4566 manual scavengers should be given identity number card by Karnataka Government, Social Welfare Department and sanctioned One Time Cash Assistance (OTCA).

Discussion:

- The Principal Secretary, Department of Social Welfare Department, addressing the committee said that even though Prohibition of Employment as Manual Scavengers and their Rehabilitation Act 2013 prohibits any worker from doing manual scavenger work. It was informed that the NGO'S team will investigate and identify the workers who are doing manual scavenging work even though there are suction machines and they will give the details of the statistics.
- Onetime cash assistance (OTCA) of Rs.40,000/- will be sanctioned to 2927 manual scavengers approved by the Central Government out of total 7483 manual scavengers identified in the survey conducted in 2013, 2016, 2018 & 2020. It was informed in meeting that the remaining 4556 applications are pending approval from the Central Government.
- Discussed about 4556 applications, manual scavengers identified after 2020 have to be uploaded on the Swachhata Abhiyan app, a live picture of them working in unhygienic toilets must also be uploaded, and all District Collectors have submitted confirmation to the central government that unhygienic toilets do not exist in the state at present.

//True copy//

• At present, if manual scavenging incidents occur, the central government will reward those who upload such images in the Swachhata app from the login of the district collector in the app.

• Also, Onetime cash assistance (OTCA) has been sanctioned to 2927 applications of manual scavengers already identified in the survey, there is a shortage of funds to provide onetime cash assistance (OTCA) to the remaining 4556 identified manual scavengers, it was informed that there is a requirement of Rs.18.5 core grant.

• Mr. E.Venkataiah, Consultant, speaking in this regard, expressed the view that One Time Grant can be sanctioned through Convergence and Convergence with other facilities already provided by Karnataka State Safai Karmachari Development Corporation.

• Principal Secretary, Social Welfare Department, explained to meeting that Karnataka State Safai Karmachari Development Corporation will provide all the facilities through Convergence; this would amounts to Rs. 70 crores to do so.

• Speaking to the Commissioner, Social Welfare Department, expressing the opinion that if identity cards are distributed to all the identified manual scavengers, it would be convenient to provide them with further facilities and a strict instruction was requested to pass in this regard.

Conclusion:

➤ A total of 7493 manual scavengers have been identified in the state and 2927 manual scavengers have been given an identification number by the central government, in which 86 manual scavengers have been submitted directly to NSKFDC without the approval of the District Collector, Out of 7493 manual scavengers approved by the survey committee, only 2841 manual scavengers will get OTCA from NSKFDC out of total pending 4650 manual scavengers and 76 families of dependents of workers who died while working in manhole/open drain/septic tanks Total 4726 manual scavengers have been decided to issue Identification numbers to the concerned District Collectors by the Social Welfare Department of the Government of Karnataka.

➤ The concerned District Collectors have to consider the matter very seriously and issue identity cards to 4650 + 76 total 4726 persons by the State Government vide Government Order No:SWD/SDC/222/2023 Dated:19.04.2023 in the prescribed format to distribute the identity card within one month from the urban local bodies and copy of it has to be sent to the Karnataka State Safai Karmacharis. In case of failure to submit to the Commission and the Corporation, disciplinary action will be recommended against the concerned District Collectors through the Controlling Officers.

➤ Convergence of various loan facility schemes along with One Time Cash Assistance (OTCA) to start alternative employment to 4726 identified manual scavengers who have been given identification number by Government, One Time Grant Rs. 1.00 lakh to be given from Karnataka State Safai Karmachari Development Corporation.

(Action: Department of Urban Development, Department of Rural Development and Panchayat Raj, Karnataka State Safai Karmacharis Development Corporation and Concerned District Collectors.)

11/04/23

11/04/23
62

Subject 3: Regarding rehabilitation of 7493 identified manual scavengers under Section 13 & 16 of MS Act 2013

Housing:

The officials of Rajiv Gandhi Housing Corporation who were present in the meeting said that 3455 houses have been reserved by Rajiv Gandhi Housing Corporation for manual scavengers, and as the concerned District Collectors have not approved and sent the list to the Corporation, therefore they remain pending from 2020-21.

The Member Secretary of the Social Welfare Department has informed that a DO letter has been written to the concerned District Collector asking the Social Welfare Department to provide a list and the Urban and Rural Development Department has also written a letter asking them to submit a list. So The Chairman directed to Principal Secretary, Social welfare Department that, issue notices to the Collectors who have not provided the list.

Advisor, SCSP/TSP Nodal Agency advised to provide financial assistance from the Corporation to the identified manual scavengers owning their own houses and dependents of deceased manual scavengers in case of need financial assistance for house repairs.

Mr. K.N.Basavantbappa, MLA, requested in the meeting to issue an order to allocate 10% of the plots to manual scavengers while constructing new layouts in urban and rural areas.

Rs 7.5 lakhs are being given to the permanent pouwa karmikas for construction of houses under the Griha Bhagya scheme, the said scheme should be extended to the manual scavengers identified under the respective local bodies and a government order should be issued and houses should be constructed and handed over to the manual scavengers who are without a house under the scheme.

Bruhat Bengaluru Mahanagara Palike (BBMP) officials speaking said that corporation is providing housing especially to pouwa karmikas through "Onti Mane" scheme similarly they can provide housing to manual scavengers.

Conclusion:

- Social welfare department to issue notices to concerned District Collectors who have not provided list of beneficiaries and immediately collect the list from District Collectors and send it to Rajiv Gandhi Development Corporation. Disciplinary action will be recommended by the Controller against the delaying Collectors.
- It was directed to Urban Development and Rural Development Department to provide Rs. 7.5 lakhs to manual scavengers as in the same pattern as that given to permanent pouwa karmikas under Gruha Bhagya Yojana.
- It was directed to Urban Development and Rural Development Department to allocate houses, while planning new layouts to the identified manual scavengers and the dependents of the deceased manual scavengers as a special category & same information to be submit a report to the next meeting.
- It was directed to Safai Karmachari Development Corporation to allocate funds in action plan to provide financial assistance for repairing houses of identified manual scavengers and dependents of deceased manual scavengers.

(Action: Department of Urban Development, Department of Rural Development and Panchayat Raj, Chief Commissioner, BBMP, Karnataka State Safai Karmacharis Development Corporation, District Collectors of all Districts)

Education:

Children of identified manual scavengers and deceased manual scavengers are being admitted to residential schools running under the Karnataka Residential Educational Institutions Society without any entrance test.

Government Order No: SWD/139/SDC/2021 Dated: 24.03.2021 In the order dated 24.10% of the urban local bodies, the concerned authorities will take action to provide educational encouragement by providing scholarships.

It was instructed to The Commissioner, Social Welfare Department to submit the proposal to the government and get an order for the scheme of admitting the children of identified manual scavengers and children of deceased manual scavengers in prestigious schools.

In order to encourage academically talented children of Safai Karmacharis and identified manual scavengers and dependents of deceased manual scavengers, the government has issued an order to celebrate the day of Dr. BR Ambedkar's admission to school as "Pratiba Puraskar Day" on 7th November and steps should be taken to implement the program effectively.

(Action: Commissioner, Social Welfare Department, Urban Development Department, Executive Director, Association of Residential Educational Institutions)

Skill Training:

District Collectors and Chief Executive Officers, Zilla Panchayats are directed to take necessary steps to provide alternative employment to the identified manual scavengers or one of their family dependents and dependents of deceased manual scavengers in their respective districts through the District Training Centers of Industries and Commerce Department in their respective districts with regard to their desired skills and training, the same list to be submitted to Safai Karmacharis Development Corporation.

(Action: Director, Department of Commerce and Industry, All District Collectors, Chief Executive Officers, Zilla Panchayat, Managing Director, Karnataka State Safai Karmacharis Development Corporation, Bangalore)

Loan Facility:

- Shri Priyank Kharge, Hon'ble Minister, Rural Development and Panchayat Raj Department, speaking suggested that manual scavengers who have already been identified and dependents of deceased manual scavengers should be mapped and credit facilities should be provided as per criteria and financial facilities should be arranged if they express their desired to do business.
- To enable the identified manual scavengers and the dependents of the deceased manual scavenger's family to start small scale industries and also provide necessary training to start the industries.
- Safai Karmachari Development Corporation has to take steps to provide financial assistance to one of the families of identified manual scavengers and one of the dependents of deceased manual scavengers to start alternative employment by ensuring mandatory skill training in case of loan and taking steps to ensure that the district authorities continuously start units for them at district level.

11/300 //True copy//
64

Legal Facility:

Even though the Manual Scavenging Act and Rule-2013 are in force in the state, the number of cases of violation of the act and deaths are increasing in the last 5 years and it is a failure of the police department.

Therefore, when the public comes to complain about such cases, the police department should co-operate and file a first information report and submit it to the sub-divisional court. Many district police officers are not aware of this act and file cases directly in district courts and many cases are acquitted. Therefore, an official note is sent by the Social Welfare Department to the Home Department to submit the cases registered in the police department directly to the sub-divisional officer's court and take action as per the law, it was suggested to take action accordingly.

- Assistant Inspector General of Police (AIG) Crime, Police Department speaking about this and said that a copy of the MS Act 2013 and Government Circular dated: 31-08-2023 to the police stations of all the districts to make them comply with the provisions of the said Act. And if a complaint is received about those who are doing manual scavenging work, the Department will also issue a separate circular and instruct them to take necessary steps to file the first information report (FIR).

- It was also brought to the attention of the meeting that the SHO's in all the police stations have been appointed as nodal officers by the department and coordinated with all other departments to take action as per the law.

- The Principal Secretary, Social Welfare Department said that if the inspectors/inspectors appointed in the districts were not functioning, the nodal officers such as joint/deputy or assistant directors of the social welfare department should file an FIR against the inspectors/inspectors as per the provisions of the Act. He informed the police department that action will be taken as per circular dated 31.08.2023.

The Minister of Rural Development and Panchayat Raj Department directed that District Police Superintendents who are members of the District Awareness Committee should attend the meeting held every three months and review the cases, solve them etc.

Conclusion:

- Mapping identified manual scavengers and dependents of deceased manual scavengers and providing credit facility for self-employment as per criteria and financial arrangement if desired to do business.
- Department of Commerce and Industry to enable identified manual scavengers and family dependents of deceased manual scavengers to start small scale industries.
- Safai Karmachari Development Corporation provides financial assistance to one of the families of identified manual scavengers and one of the dependents of deceased manual scavengers to start alternative employment by ensuring that they undergo mandatory skill training in case of giving loans.
- It was decided that District Police Superintendents are members of the District Awareness Committee and attend the meeting held every three months to review and remedy the cases of violation of the MS Act and send the review report to the state level office through proceedings and the consolidated report of the districts to be submitted by the police department to the State Monitoring Committee meeting and the commission.

65 ue copy//

- Immediately issue orders as in the official note sent by the Social Welfare Department and train all police officers in this regard.

(Action: Department of Police, Department of Commerce and Industry, Managing Director,
Karnataka State Safai Karmachari Development Corporation)

Subject 4: A total of 7493 identified manual scavengers in the state and distribution of special health card to the family dependents of those who died while performing cleaning work in manhole/septic tank/open drains/gutters to get free health care.

Discussion:

Mr. K.S. Basavanthappa, Honorable MLA, Requested the Chairman to issue a special health card to a total of 7493 identified manual scavengers in the state and 76 dependents of their families who died while cleaning manholes/septic tanks/open drains/gutters due to life-threatening diseases to get free health care services in government and private hospitals in the state.

Conclusion:

- A total of 7493 identified manual scavengers and 76 dependents of their families who died while cleaning manholes/septic tanks/open drains/sewers suffering from life-threatening diseases, will be issued special health cards by the health department within a month to get free treatment in state government, private and super specialty hospitals.

(Action: Department of Health and Family Welfare, Department of Rural Development and Panchayat Raj and Department of Urban Development)

Subject 5: Allocation of grant for total rehabilitation of total 7493 identified manual scavengers and 76 (Karnataka state resident) family dependents of laborers who died while performing manual scavenging work.

Discussion:

The Managing Director of Karnataka State Safai Karmachari Development Corporation said that the sanctioned grant to the corporation is very less and it is not possible to provide complete rehabilitation, so he proposed that the concerned departments should also allocate grants for rehabilitation for the identified manual scavengers are under the coverage of urban and rural areas.

Conclusion:

The Minister of Rural Development said that steps will be taken for rehabilitation by creating a special package in the CSR Fund.

Subject 6: Software Development

Discussion:

The Commission has arranged meetings with the Director, Directorate of Electronic Delivery Citizen Service (EDCS), Bangalore to update the rehabilitation information of 7493 manual scavengers identified in the state under section 13 and 16 of MS Act 2013 and for rehabilitation of dependents of who died while cleaning manholes/septic tanks/open drains/pit pits and complete information of safai karmacharis through mobile app Software.

//True copy//

Secretary, Karnataka State Safai karmacharis Commission, requested the committee to issue orders stating that bear the cost of the survey conducted by the Director, Directorate of Electronic Delivery Citizen Service (EDCS), Bangalore and Tala samudaayagaia Adhyayana Kendra, National Law School, Bangalore, to prepare the mobile app and to grant permission to the Karnataka State Safai Karmachari Development Corporation to maintain the said survey and mobile app.

Conclusion:

Since it is very necessary to collect the complete information and implement and maintain it in a mobile app (software), it is approved to develop the mobile app and bear the full cost of the survey and maintain it.

(Action: Directorate of Electronic Delivery Citizen Service (EDCS), Bangalore, Tala samudaayagaia Adhyayana Kendra, National Law School Bangalore, Managing Director, Karnataka State Safai Karmachari Development Corporation, Bangalore.)

Subject 7: Regarding purchase, repair and breakdown of sucking/jetting machines.

Discussion:

Shri Priyank Kharge, Hon'ble Minister speaking in the meeting said, to get the list of apartments in Bangalore and the details of those apartments where they have applied for the purchase of sucking machines so that the persons involved in manual scavenging can be identified there. Recently, two workers who were working in the maintenance of STP plant died in the apartment, due to which the situation of their family is in pathetic situation. So he directed the BWSSB Officials to collect the guidelines to check which Department has to maintain STP Plants & how to maintain it and who had supervise the same.

• Chief Engineers of Bangalore Water Supply & Sewerage Board (BWSSB) speaking in meeting said that UGD line of city limits and UGD line connected from apartments are cleaned by machines, therefore STP plants are built and maintained by BWSSB. The Karnataka State Pollution Control Board has been issued a license to maintain STP Plants in apartments.

Hon'ble Chairman speaking in the meeting said to collect the information regarding the maintenance of STP plants by Bruhat Bengaluru Mahanagara Palike (BBMP) and the STP has to be clean by sucking, jetting and rodring machines are essential and skilled workers need to be employed to maintain the STP plants and directed the officers of Bruhat Bengaluru Mahanagara Palike (BBMP), Bangalore Water Supply Sewerage Board (BWSSB), Karnataka State Pollution Control Board to collect and submit the report to government regarding numbers of STP plants working proportional to sucking, jetting and rodring machines working advise, and display the boards such as penalty & punishment of violation of MS Act, caution board & safety equipments boards in the places where apartments are constructed.

Conclusion:

- Total number of STP plants constructed in apartments in the state.

(Action: Directorate of Urban Administration and Department of Urban Development.)

- It was directed to BBMP, BWSSB and Karnataka State Pollution Control Board official to display the danger warning boards, name plate of safety equipment and punishment for violation, regarding how many STP plants have been constructed in apartments under Bangalore

Municipal Corporation and in front of them there are And directed the Pollution Control Board officials to submit a report to the Commission within one month.

(Action: BBMP B.W.SSB and Pollution Control Board)

Subject: 8 11,133 workers working under direct pay were made permanent in the first stage and 12,872 working under Direct pay still to be made permanent in the second stage.

Subject 9: Ordering consideration of direct pay for loaders, cleaners, auto and tipper drivers working in solid waste management in BBMP and other urban local bodies.

The Chairman said that as the said meeting is related to eliminate the manual scavenging and providing rehabilitation to Manual Scavengers, therefore said to conduct separate meeting relating to the Safai Karmacharis.

Subject 10 : Regarding recruitment of large number of Poura Karmikas for sanctioned posts in Gram Panchayats.

- Shri Dr. K.B. Obalesh, nominated member speaking, as per the recommendation of IPD Salappa, it has been told to take steps to hire one sanitation worker for every 1000 people in Gram Panchayats. But in the Gram Panchayats, more than the sanctioned number of Poura karmikas are being employed, and these workers are only working without proper minimum wages, It was also brought to the attention of the meeting that PF, ESI, PMJJBY, PMSBY and SBI group accident insurances are not being paid to these Poura karmikas.
- Shri D.R. Raju, a nominated member said that in many gram panchayat workers are working form 10 to 15 years, without pay for about 20-30 months have resulted in many suicide cases. Even it is difficult to maintain a family, According to JPD Saiappa's report, in urban areas one Poura karmika should appoint for 700 people, if one Poura karmika is employed for every 1000 people in Gram Panchayats, the problem will be solved. There are 6022 Gram Panchayats in the state and only 5060 workers are working, Many gram panchayats have a population of more than 12,000, hut only one Poura karmika was appointed, in some Gram Panchayats there is not even one. there is a lot of trouble without payment of wages to the workers who have been working for almost 15 years.

Conclusion:

- Directed the concerned authorities to take action for implementation of minimum wages, PF, ESI by considering the vacant posts of the workers working in existing Gram Panchayats.

(Action: Department of Rural Development and Panchayat Raj)

Subject 11: Regarding the creation of additional posts in the Karnataka State Safai Karmachari Commission.

Discussion:

- Secretary, Karnataka State Safai Karmacharis Commission said that a total of 18 posts have been sanctioned for the commission, out of which only 6 posts have been filled and 6 people are being outsourced as data entry operators. But the commission has to organize meetings with the Additional/Principal Secretary of the Government of various departments on the issues of manual scavengers/Safai Karmacharis and to send information to the Central Government every week to the Ministry of Social Affairs and Empowerment and the National Safai Karmacharis Commission and to review the grievances of the Accounts Branch, Administrative Branch, Court

11/9/2016 11:00 AM

68

C

Branch, Safai Karmacharis in the Commission. The Secretary, Karnataka State Safai Karmacharis Commission explained to the meeting that there is a need for Safai Karmacharis Branch, Manual Scavenging Eradication Branch, Research Branch of Safai Karmachari and Manual Scavengers, Numerical Branches and all the branches need an officer and staff for allocating at least 10 posts. (List attached).

Post to be Create.			
SI No	Post Details	No of Posts	Pay-scale
01	Assistant Director Grade-1	01	52,650 - 97,100
02	Assistant Director Grade-2/ Legal Officer	01	43,100 - 83,900
03	Statistical Officer (Deputation from Statistical Department)	01	37,100 - 70,850
04	Enquiry Assistant Equivalent to Office Superintendent	01	37,900 - 70,850
05	Office Superintendent	01	37,900 - 70,850
06	First Division Assistant	01	27,650 - 52,650
07	Stenographer	01	27,650 - 52,650
08	Second Division Assistant	02	21,400 - 42,000
09	Group 'D'	01	17,000 - 28,950

- Hon'ble Minister, Social Welfare Department, said that he has already discussed this with Hon'ble Chief Minister and it is requested to give additional post of Advocate General to various departments on behalf of the government. One of them has been asked to be appointed in the Social Welfare Department, which has also been approved by the Hon'ble Chief Minister, An Advocate General is being appointed soon, and he has been told to give more importance to all legal opinion related to the department and to settle the cases filed in the court and he directed the Finance Department to sanction at least 10 posts for the Safai Karmachari Commission.
- Speaking to the officials of the Department of Prosecution, said that the Karnataka State Safai Karmachari Commission is handling the court cases, there is a need for sanction & appointment of legal officers to said Commission is very essential.

Conclusion:

- To provide legal justice to the problems and grievances of Safai Karmacharis and manual scavengers, the Karnataka State Safai Karmacharis Commission has been given the power of civil court and directed the Finance Department to consider the proposal submitted by the Commission and sanction the posts as the cases are currently being filed in the Commission Court.

(Action: Department of Finance, Department of Social Welfare and Karnataka State Commission for Safai Karmacharis)

The meeting was concluded with a vote of thanks.

Sd/-

Dr || HC Mahadevappa,
Minister, Department of Social Welfare and
Hon'ble Chairman "State Monitoring Committee"

Annexure - II

SOCIAL WELFARE SECRETARIAT

NOTIFICATION

No. SWD 237 SDC 2012(5), Bangalore, dated: 03-05-2014.

In exercise of the power conferred under Section 26 of the Prohibition of Employment as Manual Scavengers and their Rehabilitation Act, 2013, the Government of Karnataka hereby notify the State monitoring Committee consisting of the Following members namely:-

State Monitoring Committee

1.	Hon'ble Minister for Social Welfare Dept.	Chair person
2.	Hon'ble Minister for Urban Development Dept.	Member
3.	Hon'ble Minister for RDPR Dept.	Member
4.	Chairperson / Karnataka State Commissions for Safai Karamcharis	Member
5.	Chairperson / Karnataka State Commissions for SC & ST	Member
6.	State representatives of the National Commission for Scheduled Castes and Safai Karamcharis	Member
7.	Two members of the State Legislature (MLAs/MLCs) belonging to the Scheduled Castes, nominated by the State Government	Member
8.	The Director-General of Police	Member
9.	ACS/ Principal Secretary of Home Department	Member
10.	Principal Secretary/Secretary of RDPR Department	Member
11.	ACS/ Principal Secretary of Urban Development Department	Member
12.	Principal Secretary/ Secretary of Social Welfare Department	Member Secretary
13.	Principal Secretary/ Secretary of Women and Child Welfare Department	Member
14.	ACS/ Principal Secretary of Commerce and Industry Department	Member
15.	Principal Secretary/Secretary of Labour Department	Member
16.	ACS/ Principal Secretary of Finance Department	Member
17.	Commissioner - BBMP	Member
18.	State Representative / General Manager from Railway Department	Member
19.	Representative from Sub-area commander Bangalore	Member
20.	Not more than four social workers belonging to organisation working for the prohibition of manual scavenging and rehabilitation of manual scavengers, or, representing the scavenger community, resident in the State, to be nominated by the State Government, two of whom shall be women;	Member
21.	Convener- SLBC	Member

1. The above said State Monitoring Committee shall meet at least once in every six months and proceedings shall be drawn and circulated.
2. The functions of the State Monitoring Committee shall be (under Section 27 of the Act) :-
 - (a) To monitor and advise the State Government and local authorities for effective implementation of this Act;
 - (b) To co-ordinate the functions of all concerned agencies.
 - (c) To look into any other matter incidental their too or connected there with for implementation of this Act.

By Order and in the name of the Governor of Karnataka,

NANJUNDAPPA

Deputy Secretary to Government
Social Welfare Department

//True copy//

/

SOCIAL WELFARE SECRETARIAT

NOTIFICATION

No. SWD 237 SDC 2012(6), Bangalore, dated: 03-05-2014.

In exercise of the power conferred under Section 24(1) of the Prohibition of Employment as Manual Scavengers and their Rehabilitation Act, 2013, the Government of Karnataka hereby notify the District Vigilance Committee and Sub divisional Vigilance Committee for each district and each sub-division.

District Vigilance Committee (Annexure - III)

1.	Deputy Commissioner / District Magistrate	Chair person
2.	All MLAs and MLCs belonging to the Scheduled Caste from the District (if a District has no member of State legislature belonging to SC the State Govt. may nominate not exceeding two other members of the State Legislature from the District.)	Member
3.	District Superintendent of Police	Member
4.	Chief executive officer of ZP	Member
5.	Commissioners of CMCs City Corporation within the District.	Member
6.	One representative to be nominated by Railway Authority located in the District	Member
7.	Not more than four social workers belonging to organization working for the Prohibition of Manual Scavenging and Rehabilitation of Manual Scavengers or representing the scavenger community, resident in the district, to be nominated by the District Magistrate, two of whom shall be women;	Member
8.	District lead bank manager or One person to represent the financial and credit institutions in the district, to be nominated by the District Magistrate;	Member
9.	DSWO of the District	Member Secretary
10.	Any District-level officers of Departments and agencies who, in the opinion of the District Magistrate have a significant role to play in the implementation of this Act (to be nominated by the DC)	Member

Sub Divisional Vigilance Committee (Annexure - IV)

1.	AC / Sub divisional Magistrate	Chair person
2.	All Executive Officer so Taluka Panchayat	Member
3.	Deputy Superintendent of Police	Member
4.	All commissioners / CEOs of CMCs / TMCs / Corporations	Member
5.	One representative to be nominated by Railway Authority located in the Subdivision	Member
6.	Two social workers belonging to organization working for the prohibition of manual scavenging and rehabilitation of manual scavengers, or, representing the scavenger community, resident in the sub-division to be nominated by the District Magistrate, one of whom shall be women;	Member
7.	One person to represent the financial and credit institutions in the sub-division, to be nominated by the Sub divisional Magistrate	Member
8.	TSWO of the sub-divisional Head quarters	Member Secretary
9.	TSWOs of other taluks within the Sub-division	Member
10.	Any sub-divisional level officers of Departments and agencies who, in the opinion of the Sub divisional Magistrate have a significant role to play in the implementation of this Act (to be nominated by the Sub divisional Magistrate)	Member

1. The above said District and Sub-divisional Vigilance Committee shall meet atleast once in every three months:
2. The functions of Vigilance Committee shall be (under Section 25 of the Act) :-
 - (a) To advise the District Magistrate or, as the case may be, the Sub-Divisional Magistrate, on the action which needs to be taken, to ensure that the provisions of this Act or of any rule made there under are properly implemented;
 - (b) To oversee the economic and social rehabilitation of manual scavengers;
 - (c) To co-ordinate the functions of all concerned agencies with a view to channelize adequate credit for the rehabilitation of manual scavengers;
 - (d) To monitor the registration of offences under this Act and their investigation and prosecution.

The Chair person of District level vigilance Committees shall inform to all the MLAs and MLCs belonging to SC within the District and also the non-official members as and when nominated in this regard.

The Chair persons of Sub divisional level vigilance Committee shall inform to all the non-official members as and when nominated in this regard.

By Order and in the name of the Governor of Karnataka,
NANJUNDAPPA
Deputy Secretary to Government
Social Welfare Department

Annexure-III

Prohibition of Manual Scavenging Act 2013, District Vigilance Committee [Section 24 (2) of MS Act 2013]

Sl. No.	District Vigilance Committee [Section 24 (2) of MS Act 2013]	Date of constitution	Date of last meeting	If not constituted, reasons thereof
1.	Bangalore Rural	15.02.2018	11.01.2023	-
2.	Bangalore Urban	10.03.2016	15.03.2023	-
3.	Bellari	25.02.2015	23.03.2023	-
4.	Belgum	27.08.2016	30.09.2022	-
5.	Bidar	09.01.2015	17.11.2022	-
6.	Vijayapura	21.03.2017	20.01.2023	-
7.	Bagalakote	05.11.2016	07.01.2023	-
8.	Chitradurga	28.01.2015	16.03.2023	-
9.	Chikamagaluru	05.01.2015	16.03.2023	-
10.	Chamrajnagar	15.12.2020	23.06.2023	-
11.	Chikkaballapur	22.08.2017	01.06.2023	-
12.	Davanagere	24.05.2017	08.06.2022	-
13.	Dharwad	12.03.2021	21.03.2023	-
14.	Dakshina Kannada	07.10.2017	29.12.2022	-
15.	Gadag	06.12.2016	16.03.2023	-
16.	Kalburgi	18.06.2018	22.12.2022	-
17.	Ramangar	29.08.2018	25.01.2023	-
18.	Haveri	28.08.2014	27.09.2021	-

73 //True copy//

19.	Koppala	23.01.2018	26.06.2023	-
20.	Kodagu	29.05.2017	20.03.2023	-
21.	Hasan	03.01.2017	09.03.2023	-
22.	Mysore	31.07.2017	30.12.2022	-
23.	Mandya	15.05.2017	21.03.2023	-
24.	Rayachuru	16.09.2018	27.03.2023	-
25.	Kolar	18.05.2019	07.12.2022	-
26.	Tumakuru	20.04.2017	14.03.2023	-
27.	Shivamoga	06.04.2017	07.11.2022	-
28.	Udupi	31.01.2018	14.06.2023	-
29.	Uttara Kannada	01.09.2014	27.03.2023	-
30.	Yadgiri	17.08.2017	22.03.2022	-
31.	Vijayanagara	20.06.2023	01.08.2023	-

ಇತ್ತೀಚೆಗೆ

74

✓

ಇತ್ತೀಚೆಗೆ

Annexure-IV

The Prohibition of Manual Scavenging Act 2013 and their Rehabilitation, Sub-Division Vigilance Committee [Section 24 (3) of MS Act 2013]

Sl. no	Sub-Division Vigilance Committee [Section 24 (3) of MS Act 2013]	Sub-Division	Date of constitution	Date of last meeting	If not constituted, reasons thereof	
1	Bangalore Urban	1	Bangalore North	01.03.2018	21.08.2023	-
		2	Bangalore South	22.02.2017	14.06.2023	-
2	Bangalore Rural	3	Doddaballapura	07.09.2017	14.07.2023	-
3	Bellari	4	Bellari	02.02.2015	26.06.2023	-
4	Belagum	5	Belagum	01.03.2017	04.09.2023	-
		6	Chikkodi	04.09.2019	08.09.2023	-
		7	Bylahongala	12.09.2019	06.06.2023	-
5	Bidar	8	Bidar	01.08.2018	26.06.2023	-
		9	Basavakalyana	01.08.2018	30.06.2023	-
6	Vijayapura	10	Vijayapura	21.03.2018	02.08.2023	-
		11	Indi	25.06.2018	07.09.2023	-
7	Bagalakote	12	Bagalakote	24.01.2017	22.06.2023	-
		13	Jamakhandi	24.01.2017	28.06.2023	-
8	Chitradurga	14	Chitradurga	01.03.2018	30.06.2023	-
		15	Hiriyuru	07.12.2018	21.03.2023	-
9	Chikamagaluru	16	Chikamagaluru	19.05.2017	06.07.2023	-
		17	Tharikere	14.02.2017	10.07.2023	-
10	Chamrajnagar	18	Kollegala	04.09.2021	21.03.2023	-
11	Chikkaballapur	19	Chikaballapura	13.10.2018	05.08.2023	-
12	Davanagere	20	Davanagere	20.03.2017	05.07.2023	-
		21	Honnali	06.03.2017	07.07.2023	-
13	Dharwad	22	Dharwada	31.07.2018	09.06.2023	-
14	Dakshina Kannada	23	Mangalore	05.07.2018	20.02.2023	-
		24	Puttur	23.02.2017	03.07.2023	-
15	Gadag	25	Gadag	14-12-2017	29.05.2023	-
16	Kalburgi	26	Kalburgi	13.06.2018	17.06.2023	-
		27	Sedam	18.04.2016	15.07.2023	-

17	Ramangar	28	Ramanagara	23.02.2018	07.06.2023	-
18	Haveri	29	Savanuru	14.07.2014	12.06.2023	-
19	Koppala	30	Koppala	07.06.2018	28.06.2023	-
20	Kodagu	31	Madikere	03.11.2015	18.07.2023	-
21	Hasan	32	Hasana	24.07.2019	28.06.2023	-
		33	Sakaleshpur	05.11.2019	21.06.2023	-
22	Mysore	34	Mysore	05.03.2021	20.06.2023	-
		35	Hunasuru	11.01.2016	13.06.2023	-
		36	Mandya	23.03.2017	13.07.2022	-
23	Mandya	37	Pandavapura	01.02.2018	19.06.2023	-
		38	Rayachuru	13.11.2019	15.07.2023	-
24	Rayachuru	39	Lingasuguru	13.11.2020	23.03.2023	-
		40	Kolar	29.06.2019	29.12.2022	-
25	Kolar	41	Tumakuru	01.09.2014	01.07.2023	-
		42	Tipturu	20.12.2019	01.07.2023	-
		43	Madugiri	01.09.2014	28.06.2023	-
26	Shivamoga	44	Shivamoga	13.03.2018	28.02.2023	-
		45	Sagara	17.11.2017	20.03.2023	-
27	Udupi	46	Kundapur	03.05.2018	05.07.2023	-
		47	Udupi	04.06.2018	30.12.2022	-
28	Uttara Kannada	48	Sirsi	06.10.2017	01.07.2023	-
		49	Kumata	08.11.2017	31.07.2023	-
		50	Batkala	20.12.2017	31.07.2023	-
		51	Karwara	18.01.2018	18.08.2023	-
29	Yadgiri	52	Yadgiri	17.08.2017	18.08.2023	-
30	Vijayanagara	53	Hosapete	19.11.2020	12.08.2022	-
		54	Harappanahalli	22.06.2023	22.06.2023	-

11/11/2023
//True copy//

Annexure-V

State Level Survey Committee (Rule 2-j of MS Rules,2013)

Sl. No.	Name of Institutions	Date of constitution	Date of last meeting	If not constituted, reasons thereof
1.	State Level Survey Committee (Rule 2-j of MS Rules,2013)	05.02.2021	23.02.2023	-

//True copy//



ಕರ್ನಾಟಕ ಸರ್ಕಾರದ ನಡವಳಿಗಳು

1. ರಾಜ್ಯದಲ್ಲಿ ಮೇ 2013ರಲ್ಲಿ ಸ್ವಾ.ಮಾ.ವಿ.ಗಳ ಸಮೀಕ್ಷೆ ಕೈಗೊಳ್ಳಲು ರಾಜ್ಯ ಮತ್ತು ಜಿಲ್ಲಾ ಮಟ್ಟದ ಸಮೀಕ್ಷಾ ಸಮಿತಿಯನ್ನು ರಚಿಸಲು ಸರ್ಕಾರ ಆದೇಶ ಹೊರಡಿಸುವ ಬಗ್ಗೆ.

- 2. ಓದಲಾಗಿದೆ. 1 ಅಧಿನಿಯಮ ಸಂಖ್ಯೆ. ಸಂಖ್ಯೆ 50 ಜನವರಿ 2012, ದಿನಾಂಕ: 04-01-2013.
- 3. ಸರ್ಕಾರದ ಆದೇಶ ಸಂಖ್ಯೆ. ಸಂಖ್ಯೆ 32 ಜನವರಿ 2017, ದಿನಾಂಕ: 03.04.2017.
- 4. ಕಾರ್ಯದರ್ಶಿ, ಕರ್ನಾಟಕ ರಾಜ್ಯ ಸರ್ಕಾರದ ಕಾರ್ಯಾಲಯ ಆಯೋಗ ಇವರ ಪತ್ರ ಸಂಖ್ಯೆ: ಕರ್ನಾಟಕ/ಎಚ್-9/ಪ್ರಸ್ತಾವನೆ/ ಸಿಆರ್-01/ 2020-21, ದಿನಾಂಕ:13-01-2021.

ಪ್ರಸ್ತಾವನೆ:

ಮೇಲೆ ಕ್ರಮಾಂಕ (1) ರಲ್ಲಿ ಓದಲಾದ ಅಧಿನಿಯಮವನ್ನು ಕರ್ನಾಟಕ ರಾಜ್ಯ ಸರ್ಕಾರದ ಕಾರ್ಯಾಲಯಗಳ ಆಯೋಗವನ್ನು ರಚಿಸಲಾಗಿದೆ, ಸರ್ಕಾರದ ಕಾರ್ಯಾಲಯಗಳ ಸರ್ಕಾರೀ ಅಧಿಕಾರಿಗಳಿಗೆ ಹಾಗೂ ಸಾಮಾಜಿಕ ಭದ್ರತೆಗಾಗಿ ಆಯೋಗವು ಕರ್ನಾಟಕ ರಾಜ್ಯ ಸರ್ಕಾರದ ಕಾರ್ಯಾಲಯಗಳ ಆಯೋಗ ಅಧಿನಿಯಮ, 2012 ಹಾಗೂ 2013ರ ಕರ್ನಾಟಕ ಅಧಿನಿಯಮ ಸಂಖ್ಯೆ 2 ರನ್ವಯ ಪ್ರಕಾಶನಗಳನ್ನು ನಿರವರಿಸುತ್ತಿದೆ. ಮ್ಯಾನ್ಯೂಯಲ್ ಸ್ವಾ.ಮಾ.ವಿ.ಗಳ ಸಮುದಾಯವು ಒಂದು ಸುಸ್ಥಿರವಾದ ತೊಂದರೆಯಿಂದಾಗಿ ಅವರ ಮಕ್ಕಳಿಗೆ ಉತ್ತಮ ಶಿಕ್ಷಣ, ಕುಟುಂಬಕ್ಕೆ ಅರ್ಥಿಕ ಭದ್ರತೆ ನೀಡುವಲ್ಲಿ ಕೇಂದ್ರ ಸರ್ಕಾರದ ನಡವಳಿ ಕಾಯಿದೆ "THE PROHIBITION OF EMPLOYMENT AS A MANUAL SCAVENGERS AND THEIR REHABILITATION ACT 2013" ರಲ್ಲಿ ತಿಳಿಸಿರುವ ಕಾರ್ಯಕ್ರಮ ಅರ್ಥಪೂರ್ಣವಾಗಿ ಕಾರ್ಯರೂಪಕ್ಕೆ ತರುವ ಆಯೋಗವು ಪ್ರವೇಶಿಸುತ್ತಿದೆ. ರಾಜ್ಯ ಸರ್ಕಾರದ ಕಾರ್ಯಾಲಯ ಆಯೋಗವು "ರಾಷ್ಟ್ರೀಯ ಸರ್ಕಾರದ ಕಾರ್ಯಾಲಯಗಳ ಆಯೋಗ, ನವದೆಹಲಿ" ಕಾಲ ಕಾಲಕ್ಕೆ ನೀಡುವ ಸಲಹಾ ಸೂಚನೆಗಳನ್ನು ಪಾಲಿಸುತ್ತಿದೆ.

ಮೇಲೆ ಕ್ರಮಾಂಕ (2) ರಲ್ಲಿ ಓದಲಾದ ಆದೇಶದಲ್ಲಿ ಮ್ಯಾನ್ಯೂಯಲ್ ಸ್ವಾ.ಮಾ.ವಿ.ಗಳ ಕಾಯಿದೆ 2013 ಸೆಕ್ಷನ್ 32(1)ರ ಪ್ರಕಾರ ಕರ್ನಾಟಕ ರಾಜ್ಯ ಸರ್ಕಾರದ ಕಾರ್ಯಾಲಯಗಳ ಆಯೋಗವನ್ನು "THE PROHIBITION OF EMPLOYMENT AS A MANUAL SCAVENGERS AND THEIR REHABILITATION ACT 2013" ರ ಅನುಷ್ಠಾನದ ಬಗ್ಗೆ ಮೇಲ್ವಿಚಾರಣೆ ಮಾಡಲು ಯುಕ್ತ ವ್ಯಾಧಿಕಾರವಾಗಿ ನೇಮಕ ಮಾಡಲಾಗಿದೆ.

ಮೇಲೆ ಕ್ರಮಾಂಕ (3) ರಲ್ಲಿ ಓದಲಾದ ಪತ್ರದಲ್ಲಿ ಕಾರ್ಯದರ್ಶಿ, ಕರ್ನಾಟಕ ರಾಜ್ಯ ಸರ್ಕಾರದ ಕಾರ್ಯಾಲಯಗಳ ಆಯೋಗ ಇವರು ಮ್ಯಾನ್ಯೂಯಲ್ ಸ್ವಾ.ಮಾ.ವಿ.ಗಳ ಕಾಯಿದೆ 2013ರ ನಿಯಮದ ಅಧ್ಯಾಯ 1(2)(4)ರಲ್ಲಿ ಜಿಲ್ಲಾ ಮಟ್ಟದ ಸಮೀಕ್ಷಾ ಸಮಿತಿ ಮತ್ತು 1(2)(ಎ)ರಲ್ಲಿ ರಾಜ್ಯಮಟ್ಟದ ಸಮೀಕ್ಷಾ ಸಮಿತಿಗಳ ರಚನೆ ಹಾಗೂ ಅವುಗಳ ಕಾರ್ಯಗಳ ಬಗ್ಗೆ ಜಿಲ್ಲಾ ಮತ್ತು ರಾಜ್ಯ ಮಟ್ಟದಲ್ಲಿ ಅನುಷ್ಠಾನಗೊಳಿಸುವ ಸಂಬಂಧ ಈ ಕೆಳಗಿನ ಸಂಯೋಜನೆಯೊಂದಿಗೆ ಸರ್ಕಾರದಿಂದ ರಾಜ್ಯವ್ಯಾಪ್ತ ಅಧಿನಿಯಮ ಜಾರಿಯಾಗುವಂತಿರುತ್ತದೆ. ಮಾನ್ಯ ಕರ್ನಾಟಕ ಉಚ್ಚ ನ್ಯಾಯಾಲಯವು ರಿಟ್ ಅರ್ಜಿ ಸಂಖ್ಯೆ: 8928/2020ರಲ್ಲಿ ನೀಡಿರುವ ಆದೇಶದಲ್ಲಿ ಮೇಲ್ಕಂಡ ಸಮಿತಿಗಳ ರಚನೆ ಹಾಗೂ ಅವುಗಳ ಕಾರ್ಯಗಳ ಬಗ್ಗೆ ಸರ್ಕಾರದಲ್ಲಿ ಕ್ರಮ ಕೈಗೊಳ್ಳಲು ಮಧ್ಯಂತರ ನಿರ್ದೇಶನ ನೀಡಲಾಗಿರುತ್ತದೆ ಹಾಗೂ ಈ ಕುರಿತು ಕೈಗೊಂಡ ಕ್ರಮದ ಬಗ್ಗೆ ಮಾನ್ಯ ಕರ್ನಾಟಕ ಉಚ್ಚ ನ್ಯಾಯಾಲಯಕ್ಕೆ ದಿನಾಂಕ 30.01.2021ರೊಳಗೆ ಅನುಸರಣಾ ಪ್ರಮಾಣ ಪತ್ರ (Compliance Affidavits) ವನ್ನು ಸಲ್ಲಿಸುವಂತಿರುತ್ತದೆ. ಆದಕಾರ, ಮೇಲ್ಕಂಡಂತೆ ಜಿಲ್ಲಾ ಮತ್ತು ರಾಜ್ಯಮಟ್ಟದ

//True copy//

True copy

1. ...
2. ...
3. ...
4. ...
5. ...
6. ...

...

...	...	9
...	...	8
...	...	7
...	...	6
...	...	5
...	...	4
...	...	3
...	...	2
...	...	1

...

...

...

...

...

...

ಅ) ಜಿಲ್ಲಾ ಮಟ್ಟದ ಸಮೀಕ್ಷಾ ಸಮಿತಿ:-

1	ಜಿಲ್ಲಾಧಿಕಾರಿ	ಅಧ್ಯಕ್ಷರು
2	ಮಂಜು/ಲಲಿತ ನಿರ್ದೇಶಕರು, ಸಮಾಜ ಕಲ್ಯಾಣ ಇಲಾಖೆ	ಸಹಾಯಕ ಕಾರ್ಯದರ್ಶಿ
3	ಜಿಲ್ಲಾ ಸಾಂಸ್ಕೃತಿಕ ಅಧಿಕಾರಿ	ಸದಸ್ಯರು
4	ಆಯುಕ್ತರು, ನಗರ ಪಾಲಿಕೆ / ಪರಿಶಿಷ್ಟ ಜಾತಿ/ ಬ್ರಹ್ಮಣ್ಯ ಬೆಂಗಳೂರು ಮಹಾನಗರ ಪಾಲಿಕೆ	ಸದಸ್ಯರು
5	ಜಿಲ್ಲಾ ಮಟ್ಟದ ರೈಲ್ವೇ ಇಲಾಖೆಯ ಒಬ್ಬ ಪ್ರತಿನಿಧಿ	ಸದಸ್ಯರು
6	ಮ್ಯಾನ್ಯೂಯಲ್ ಸ್ಕ್ಯಾಂಪೆಂಜರ್ಸ್ ಗಳ ಮತ್ತು ಸಫಾಯಿ ಕೆರ್ಮಿನಾಟಿಂಗ್ ಕಲ್ಯಾಣಕ್ಕಾಗಿ ಕೆಲಸ ಮಾಡುವ ಸರ್ಕಾರೀತರ ಸಂಸ್ಥೆಗಳಿಂದ (ಜಿಎಸ್‌ಡಿ) ಜಿಲ್ಲಾಧಿಕಾರಿ - ನಾಮನಿರ್ದೇಶನ ಮಾಡುವ ಗೌಪ್ಯ ಇಬ್ಬರು ಪ್ರತಿನಿಧಿಗಳು (ಅಯಾ ಜಿಲ್ಲಾಧಿಕಾರಿಗಳು ನಾಮ ನಿರ್ದೇಶನ ಮಾಡುವುದು)	ಸದಸ್ಯರು
7	ಗೌಪ್ಯ ಇಬ್ಬರು ಸಮುದಾಯ ಪ್ರತಿನಿಧಿಗಳು, ಇವರಲ್ಲಿ ಒಬ್ಬರು ಮಹಿಳಾ ಪ್ರತಿನಿಧಿಯಾಗಿದ್ದು ಅವರನ್ನು ಜಿಲ್ಲಾಧಿಕಾರಿ - ನಾಮನಿರ್ದೇಶನ ಮಾಡಬೇಕು (ಅಯಾ ಜಿಲ್ಲಾಧಿಕಾರಿಗಳು ನಾಮ ನಿರ್ದೇಶನ ಮಾಡುವುದು)	ಸದಸ್ಯರು

ಜಿಲ್ಲಾ ಮಟ್ಟದ ಸಮೀಕ್ಷಾ ಸಮಿತಿಯ ಕಾರ್ಯಗಳು:-

1. ಜಿಲ್ಲಾ ಮಟ್ಟದಲ್ಲಿ ಸಮೀಕ್ಷಾ ಪ್ರಕ್ರಿಯೆಯ ಉನ್ನತವಾಗಿ ಮತ್ತು ಮೇಲ್ಮಟ್ಟದವಾಗಿ ಮಾಡುವುದು.
2. ಜಾಗೃತಿ ಪ್ರಚಾರಕ್ಕಾಗಿ ಸಾಮಗ್ರಿಗಳನ್ನು ಗೊತ್ತುಪಡಿಸಿದ ಸ್ಕೋಪ್, ವಿತರಿಸುವುದು.
3. ಸಮೀಕ್ಷೆಯ ಕುರಿತು ಸ್ಥಳೀಯ ವ್ಯಕ್ತಿತ್ವಗಳನ್ನು, ಮುಖಂಡರುಗಳ ಮೂಲಕ ಪ್ರಚಾರಕ್ಕೆ ವ್ಯವಸ್ಥೆ ಮಾಡುವುದು.
4. ಭಾಷಾಂತರಿಸಿದ ಸಮೀಕ್ಷಾ ಸಾಮಗ್ರಿಗಳನ್ನು ಶಬ್ದ ಕಾರ್ಯವ್ಯಾಪ್ತಿಗೆ ಬರುವ ಪ್ರದೇಶದಲ್ಲಿ ಗೊತ್ತುಪಡಿಸಿದ ಸ್ಕೋಪ್, ವಿತರಿಸುವುದು.
5. ಜಿಲ್ಲೆಯ ಜಿಲ್ಲಾ ಪಟ್ಟಣಗಳು, ನಗರಗಳು ಮತ್ತು ಗ್ರಾಮಗಳಿಗೆ ಮ್ಯಾನ್ಯೂಯಲ್ ಸ್ಕ್ಯಾಂಪೆಂಜರ್‌ಗಳ ಅಂತಿಮ ಪಟ್ಟಿಯನ್ನು ಅನುಮೋದಿಸುವುದು.
6. ಜಿಲ್ಲೆಯಲ್ಲಿರುವ ಮ್ಯಾನ್ಯೂಯಲ್ ಸ್ಕ್ಯಾಂಪೆಂಜರ್‌ಗಳ ಅಂತಿಮ ಕ್ರೋಢೀಕರಿಸಿದ ಪಟ್ಟಿಯನ್ನು ಪ್ರಕಟಿಸುವುದು.
7. "ಪರಿಶಿಷ್ಟರ (ಜಿಎಸ್‌ಡಿ) ಅಂದರೆ ಮ್ಯಾನ್ಯೂಯಲ್ ಸ್ಕ್ಯಾಂಪೆಂಜರ್‌ಗಳ ಸಮೀಕ್ಷೆ ಅಥವಾ ಪರಿಶೀಲನೆಗಾಗಿ ಸ್ಥಳೀಯ ಪ್ರಾಧಿಕಾರದಿಂದ ನೇಮಿಸಲ್ಪಟ್ಟ ಯಾವುದೇ ವ್ಯಕ್ತಿ ಎಂದರ್ಥ.
8. "ಪರಿಶಿಷ್ಟ (ಜಿಎಸ್‌ಡಿ) ಅಂದರೆ ಸೂಕ್ತ ಸರ್ಕಾರದಿಂದ ಕಾಯ್ದೆಯ ವಿಷಯ 20ರ ಉಪ ವಿಧ (1) ನಿಬಂಧನೆಗಳ ಪ್ರಕಾರ "ಪರಿಶಿಷ್ಟ" ಎಂದು ನೇಮಕಗೊಂಡ ಒಬ್ಬ ವ್ಯಕ್ತಿ.
9. "ಮೇಲ್ಮಟ್ಟದ (ಜಿಎಸ್‌ಡಿ) ಅಂದರೆ ಈ ನಿಬಂಧನೆಗಳ ಅನ್ವಯದಲ್ಲಿ ಅಧಿಕಾರವನ್ನು ಚಲಾಯಿಸಲು ಮತ್ತು ಕರ್ತವ್ಯಗಳನ್ನು ನಿರ್ವಹಿಸಲು ಸ್ಥಳೀಯ ಅಧಿಕಾರದಿಂದ ನೇಮಿಸಲ್ಪಟ್ಟಿರುವ ಒಬ್ಬ ಅಧಿಕಾರಿ.

ಕರ್ನಾಟಕ ರಾಜ್ಯ ಕಾಲರ ಅಧಿಕಾರನುಸಾರ

ಮತ್ತು ಅದರ ಪರಿಷ್ಕರಣೆ

5/2/2021
(ಪಿ.ಎಸ್. ಸುಗುಂಡಾಚ್)

ಸರ್ಕಾರದ ಅಧೀನ ಕಾರ್ಯದರ್ಶಿ-3,

ಜಿಲ್ಲಾ ಸಮಾಜ ಕಲ್ಯಾಣ ಇಲಾಖೆ.

ಇವರಿಗೆ:

ಸರ್ಕಾರದ ಕಾರ್ಯದರ್ಶಿ, ಕರ್ನಾಟಕ ರಾಜ್ಯ ಮತ್ತು ಬೆಂಗಳೂರು- ಮುಂದಿನ ಸಂಚಿಕೆಯಲ್ಲಿ ಪ್ರಕಟಿಸಿ 100 ಪ್ರತಿಗಳನ್ನು ಸರ್ಕಾರದ ಅಧೀನ ಕಾರ್ಯದರ್ಶಿ, ಸಮಾಜ ಕಲ್ಯಾಣ ಇಲಾಖೆ, ಕೊಡಗಿ ಸಂಖ್ಯೆ: 232, 2ನೇ ಮಹಡಿ, ಕರ್ನಾಟಕ ಬೆಂಗಳೂರು ರವರಿಗೆ ಕಳುಹಿಸಿಕೊಡುವಂತೆ ಕೋರಿದೆ.

True copy//

ಇವುಗಳಿ-

1. ಮಹಾಲೇಖಾಲಯ, (ಲೆಕ್ಕ, ವಜ್ರ, & ಲೆಕ್ಕಪರಿಶೋಧಕ), ಕರ್ನಾಟಕ, ಬೆಂಗಳೂರು.
2. ಸರ್ಕಾರದ ಕಾರ್ಯದರ್ಶಿ, ಕರ್ನಾಟಕದ ವಿ. ಸಿ. ಆಯ್ಕೆ, ಸಿ. ಕರ್ನಾಟಕ, ಬೆಂಗಳೂರು.
3. ಆಯುಕ್ತರು, ಸಮಾಜ ಕಲ್ಯಾಣ ಇಲಾಖೆ, ಬೆಂಗಳೂರು.
4. ನಿರ್ದೇಶಕರು, ಮಾಹಾತ್ಮಜ ನಿರ್ದೇಶನಾಲಯ, ಬೆಂಗಳೂರು.
5. ಕಾರ್ಯದರ್ಶಿ, ಕರ್ನಾಟಕ ರಾಜ್ಯ ಸಭೆಯ ಕಾರ್ಯಾಲಯ ಅಧೀನ, ಬೆಂಗಳೂರು.
6. ಎಲ್ಲಾ ಜಿಲ್ಲೆಯ ಜಿಲ್ಲಾಧಿಕಾರಿಗಳು.
7. ಎಲ್ಲಾ ಜಿಲ್ಲೆಯ ಮುಖ್ಯ ಕಾರ್ಯನಿರ್ವಹಣಾಧಿಕಾರಿಗಳು, ಜಿಲ್ಲಾ, ಹಂಪಿಯೂರ್.
8. ಸಮಿತಿಯ ಸದಸ್ಯರುಗಳಿಗೆ (ಕಾರ್ಯದರ್ಶಿ, ಕರ್ನಾಟಕ ರಾಜ್ಯ ಸಭೆಯ ಕಾರ್ಯಾಲಯ ಅಧೀನ, ಬೆಂಗಳೂರು ಇದರ ಮೂಲಕ)
9. ಯಾವ ರಕ್ಷಾ ಕವಚ/ಹೆಚ್ಚುವರಿ ಪ್ರತಿಗಳು.

ಪ್ರತಿ ಮಾಹಿತಿಗಾಗಿ:-

1. ಮಾನ್ಯ ಸಮಾಜ ಕಲ್ಯಾಣ ಸಚಿವರ ಆಪ್ತ, ಕಾರ್ಯದರ್ಶಿಯವರು ನಿರ್ದೇಶಿಸಿ, ಬೆಂಗಳೂರು.
2. ಸರ್ಕಾರದ ಆಪ್ತ ಮುಖ್ಯ ಕಾರ್ಯದರ್ಶಿಯವರ ಆಪ್ತ, ಕಾರ್ಯದರ್ಶಿ, ಸಮಾಜ ಕಲ್ಯಾಣ ಇಲಾಖೆ.
3. ಸರ್ಕಾರದ ಉಪ ಕಾರ್ಯದರ್ಶಿ-1, ಇದರ ಆಪ್ತ ಸಮಾಜಕರು, ಸಮಾಜ ಕಲ್ಯಾಣ ಇಲಾಖೆ

.....

//True copy//

Annexure-VI

The Prohibition of Manual Scavenging Act and their Rehabilitation 2013, District level survey committee (Rule 2-c of MS Rules 2013)

Sl. No.	Name of the District	Date of constitution	Date of last meeting	If not constituted, reasons thereof
1.	Bangalore Rural	23.03.2021	27.07.2021	-
2.	Bangalore Urban	23.02.2021	27.07.2021	-
3.	Bellari	04.03.2021	03.03.2022	-
4.	Belgum	08.02.2021	27.10.2021	-
5.	Bidar	06.04.2021	08.12.2022	-
6.	Vijayapura	20.03.2021	21.03.2022	-
7.	Bagalakote	18.03.2021	20.10.2021	-
8.	Chitradurga	04.03.2021	17.03.2022	-
9.	Chikamagaluru	03.04.2021	08.03.2022	-
10.	Chamrajnagar	05.03.2021	08.04.2022	-
11.	Chikkaballapur	22.03.2021	24.03.2022	-
12.	Davanagere	25.02.2021	23.12.2021	-
13.	Dharwad	22.01.2021	26.07.2021	-
14.	Dakshina Kannada	15.04.2021	28.02.2022	-
15.	Gadag	25.02.2021	16.03.2022	-
16.	Kalburgi	23.02.2021	23.09.2021	-
17.	Ramangar	23.02.2021	05.04.2022	-
18.	Haveri	12.04.2021	29.06.2021	-
19.	Koppala	22.03.2021	22.02.2022	-
20.	Kodagu	17.03.2021	01.04.2022	-
21.	Hasan	23.02.2021	21.03.2022	-

//True copy//

82

✓

22.	Mysore	05.03.2021	02.08.2021	-
23.	Mandya	23.02.2021	07.03.2022	-
24.	Rayachuru	23.02.2021	16.08.2021	
25.	Kolar	25.02.2021	01.04.2021	-
26.	Tumakuru	08.03.2021	18.03.2022	-
27.	Shivamoga	25.02.2021	10.03.2022	-
28.	Udupi	03.03.2021	23.02.2022	-
29.	Uttara Kannada	03.03.2021	19.01.2022	-
30.	Yadgiri	17.02.2021	08.03.2022	-
31.	Vijayanagar	02.11.2021	30.03.2022	

//True copy//

Annexure-VII

Details of all prosecutions initiated for manual scavenging and insanitary latrines ever since the 2013 Act came into force, alongwith details of the exact stage of each prosecution.

Sl. No.	District	Name of the offender	Name of Manual Scavengers	Date of occurrence	FIR No./Date and Sections	Current status of Investigation/Prosecution
1	Bangalore Urban	Sri Suri Bin Mutturaj	Ramesh Yesu	08.04.2019	No. 0059/2019 (MS Act 2013 U/S-5, 8 & 9) dt.09.04.2019	Processing
2		Bangalore Skywood Apartment		20.07.2019	No. 0216/2019 (MS Act 2013 U/S-5, 8 & 9) Dt.21.07.2019	Processing
3	Kalburgi	Shuvaji Mehtar	Radha Suresh Arnith Kumar	26.06.2019	No. 0069/2019 (MS Act 2013 U/S-5, 8 & 9) Dt.27.06.2019	Processing
5	MySore	Nagaratna	Sri Rajesh Madhu	17.12.2021	0331/2021 (MS Act 2013 U/S-5, 8 & 9) dt. 18.12.2021	Processing
6	Uttara Kannada	C.M.C Municiple Mukundam	Ranganaiik Abhshek Dugipogu Manjunath Modikara Narasimha Dasari	11.12.2019	No. 0117/2019 Dt.12.12.2019 (MS Act 2013 U/S-5, 8 & 9)	Processing

//True copy//

Annexure VI

**Details of cases & persons death accrued during
manual scavenging work in Karnataka State from
1993**

SL No	District	Total
1.	Bangalore Urban	42
2.	Bangalore Rural	04
3.	Mysore	06
4.	Mandya	01
5.	Hassan	05
6.	Kolar	05
7.	Tumkur	04
8.	Chamarajanagara	01
9.	Shivamoga	04
10.	Raichur	01
11.	Udupi	01
12.	Dharwad	09
13.	Vijayapura	03
14.	Uttara kannada	01
15.	Kalaburagi	02
16.	Ramanagara	03
	Total	92

The details of Manual Scavengers who died while doing Manual Scavenging

Sl. No	Year	Dist Name	The name of the Manual Scavenger/Civic Worker who died while cleaning the Manhole/Septic Tank	Age	Caste & Sub Caste	Place of Incident occurred	The Compensation paid As per Supreme Court Judgment	The Compensation paid As per POA	Total Compensation Given	Rehabilitation Details	FIR Details		Case status Report	Department/Urban Local/Original office/Corporation give compensation	Name and Address of the Dependents	Remarks		
											FIR No & Date	Section						
1	1995-96	Chamrajnagar	Sri Chinnaswamy Bisi Chinnado	-	SC (Adi Dravida)	PK Colony, Ward No.09, Kartinjanapora, Chamrajnagar Town, Chamrajnagar Dist	10,00,000/-	-	10,00,000/-		UDR No: 011/1995 Dt: 11.05.1995 Chamrajnagar Town PS	U/s 174 CrPC	Case status report not Given by Police Dept	Commissioner, Municipal Council, Chamrajnagar.	Smt. Rangaruna (wife)	UDR CASE - Case has not registered on POA 1989. No Rehabilitation detail given by DSW		
2	1998-99	Hassan	Sri Maranna	-	Others	Open Manhole at KSRTC Channarayana, Hassan Dist	10,00,000/-	-	10,00,000/-		UDR No: 24/98 Dt: 17.11.1998 Channarayana PS	U/s 174 CrPC	Final report has submitted	KSRTC Channarayana	Smt Nagamma (mother)	UDR CASE- Case has not registered on POA 1989. No Rehabilitation detail given by DSW		
3			Sri Harasimharaju	16 Year	Others		10,00,000/-	-	10,00,000/-				Smt Gowramma (mother)					
4			Sri Nagaraju	-	SC		10,00,000/-	-	10,00,000/-				Smt Padma					
5	2001-02	Mysore	Sri Shankar	29 Year	SC (Adi Dravida)	Opp. Santa Filomina Church, Mysore	10,00,000/-	-	10,00,000/-		UDR No: 5/2001 Dt: 01/06/2001 Lashkar PS, Mysore.	U/s 174 CrPC	Case closed	Executive Engineer, Sewer Section, Mysore city corporation	Smt Rajamma late Shankar	UDR CASE- Case has not registered on POA 1989. No Rehabilitation detail given by DSW		
6	2007-08	Hubli-Dharwad	Sri Shankar Kutsar	23 Year	Kulkaligara	Infront of Old Hubballi Police Chouki	10,00,000/-	-	10,00,000/-		UDR No: 009/2007 Dt: 06.04.2007 Old Hubballi PS	U/s 174 CrPC	Final report has submitted	Hubballi-Dharwad city corporation	Smt Lakshmi (wife)	UDR CASE- Case has not registered on POA 1989. No Rehabilitation detail given by DSW		
7			Sri Shivaputrappa	38 Year	SC (Madara)		10,00,000/-	-	10,00,000/-				Smt Gangavva (wife)					
8	2008-09	Bengaluru Urban	Sri Amaresh	23 Year	-	Yalahanka New Town (Dairy Circle).	10,00,000/-	-	10,00,000/-		266/2008 Dt: 14.11.2008 Yalahanka New town PS	U/s 304 (A) IPC 1960	Case closed	BWSSB	Gundappa (Father) Ambamma (Mother)	Case has not registered on POA 1989. No Rehabilitation detail given by DSW		
9			Sri Narasimha	32 Year	-		10,00,000/-	-	10,00,000/-				Nagamma (Wife)					
10			Sri Sivas	23 Year	ST (Nayaka)		10,00,000/-	-	10,00,000/-				Krishnappa (Father)					
11			Sri Krishnappa	35 Year	SC	10,00,000/-	-	10,00,000/-		278/2008 Dt: 05.07.2008 Electronic City PS	U/s 337, 304 (A) IPC 1860	D' Final Report submitted on 26.08.2008	Velankani Pvt Ltd	Chinnappa (father), Guramma (mother), K. Roopa (Daughter)	Case has not registered on POA 1989. No Rehabilitation detail given by DSW			
12			Sri Remachandra	25 Year	SG (Bovi)	10,00,000/-	-	10,00,000/-					Smt Shakuntala (wife)					
13	Mysore	Sri Kariya	38 Year	SC (Adi Dravida)	7th Main Road, Circle Infront of Geetha Auto Workers, Drainage, KR Nagar Town, Mysore Dist.	10,00,000/-	-	10,00,000/-	Diseased person son Sri Lamesh has got Pourakarmika job under direct appointment.	C.No. 69/2008 Dt: 09.04.2008 K.R. Nagar PS	U/s 337, 304 (A) IPC 1860	Case has acquitted on 05.12.2012	Municipal Corporation, Krishnaranagar, Mysore Dist.	Smt Saroja (wife)	Case has not registered on POA 1989.			
14			Sri Lakshman	40 Year	SC (Adi Dravida)	10,00,000/-	-	10,00,000/-	Diseased person wife Smt Lakshmi has got Pourakarmika job under direct appointment.				Lakshmi (wife)					
15	2009-10	Bengaluru Urban	Sri Rajanna	35 Year	Okkaliga	Karim Sab Layout, Peenya 2nd Stage.	10,00,000/-	-	10,00,000/-		FIR No. 024/2009 Dt: 09.05.2009 Rajogopal Nagar PS	U/s 174 Cr.PC 1973	Case closed on 25.05.2011	BBMP	Smt Savithra (wife)	Case has not registered on POA 1989. No Rehabilitation detail given by DSW		
16			Sri Shivu	33 Year	Cikkaliga		10,00,000/-	-	10,00,000/-									Cbethan Kumar & Kishan
17			Sri Pampanna	35 Year	SC		10,00,000/-	-	10,00,000/-									Smt Savithramma
18	2010-11	Kolar	Sri Manjunath	-	SC (Bovi)	RTO Kolar City	10,00,000/-	-	10,00,000/-		FIR No. 191/10 Dt: 11.12.2010 Kolar Town PS	U/s 204 (A) IPC 1860	Case has acquitted on 19.09.2011	Karnataka Water Supply and Drainage Board	Gangamma (wife)	Case has not registered on POA 1989. No Rehabilitation detail given by DSW		
19			Sri Rajanna	-	SC (Bovi)		10,00,000/-	-	10,00,000/-									Rajanna Bin Muniyappa
20	Hassan	Sri Mahadev	35 Year	SC	Pooranarama Cofee Estate, Kenchamma Hosakote, Alur Tq, Hassan Dist.	10,00,000/-	-	10,00,000/-		0224/2011 Dt: 23.07.2011 Alura PS	Employment of Manual Scavengers & Construction of Dry Latrines (prohibition) Act, 1993 U/s: 3(1)(c), 14.	Case has Acquired	Owner of Pooranarama Cofee Estate, Alur Tq, Hassan Dist.	Smt Gowri (wife)	Case has not registered on POA 1989. No Rehabilitation detail given by DSW			
21			Sri Arjuna	22 Year	SC	10,00,000/-	-	10,00,000/-									Smt Subamma (wife)	

86 True copy

The details of Manual Scavengers who died while doing Manual Scavenging

Sl. No.	Year	Dist Name	The name of the Manual Scavenger/Civic Worker who died while cleaning the Manhole/Septic Tank	Age	Caste & Sub Caste	Place of Incident occurred	The Compensation paid As per Supreme Court Judgment	The Compensation paid As per POA	Total Compensation Given	Rehabilitation Details	FIR Details		Case status Report	Department/Urban Local Organi zation/Government agency giving compensation	Name and Address of the Dependents	Remarks
											FIR No & Date	Section				
22	2011-12	Kolar	Sri Kuttly Prasad	35 Year	SC	Robertsonper Municipality Corporation area Manhole	10,00,000/-	-	10,00,000/-	* Rs.1,00,000/- Has been given to the dependants of the family under different schemes of Dr BR Ambedkar Dev. Corp. * Kuttly Prasad wife Smt Shanti has been appointed as PK on direct payment.	167/2011 Dt: 24.10.2011 Robertson Pct PS	304, 34 IPC R/W 14, 3 (1)(A) Manual Scavengers and construction of Dry latrines prohibition Act, 1993 and sec. 3(1)(3) SC/ST POA 1989	The complainant and Accused comprised. Hence case is Acquitted on 21.04.2015 In CC No. 67/2012 In Senior Adl. Civil Judge and JMFC Court, KGF.	CMC Robertsonpet Social Welfare Department, Revenue Department	Smt Shanti (wife)	Case has not registered on POA 1989.
23			Sri Nagendra Rahu	26 Year	SC	10,00,000/-	-	10,00,000/-	Rs.1,00,000/- Has been given to the dependants of the family under different schemes of Dr BR Ambedkar Dev. Corp.	Smt Shilpa (wife)						
24			Sri Ravi	29 Year	SC	10,00,000/-	-	10,00,000/-	* Rs.1,00,000/- Has been given to the dependants of the family under different schemes of Dr BR Ambedkar Dev. Corp. * Ravi wife Smt Janaki has been appointed as PK on direct payment.	Smt Janaki (wife)						
25	2011-12	Tumkur	Sri Jagadish	-	Odkkaliga	Rightside manhole of the Bypass road of Towards Tumkur From Tiptur KSRTC bus stand	10,00,000/-	-	10,00,000/-	-	147/2011 Dt: 19.12.2011 Tipturu Towo PS	0/s 304(a) r/w 34 IPC	Chargesheet has been Submitted.	KBR Infracon Ltd, Bangalore, KUIDFC	KR Manjushetty (Father), KM Geetha (Sister) Smt Dralshayanamma (wife)	Case has not registered on POA 1989. No Rehabilitation detail given by DSW
26			Sri Dharma Bin Susheelamma	-	Madiyala	10,00,000/-	-	10,00,000/-	-	-	-	-	-	-	-	-
27	2012-13	Hubli-Dharwad	Sri Yakoob Yalopathi	50 Year	SC (Dalit Samudaya)	Opp. Apoorva Showroom, P B Road, Gataru Mala, Dharwad	10,00,000/-	-	10,00,000/-	-	24/2012 Dt: 16.02.2012 Vidya giri PS	IPC 1860 U/s 304(a) r/w 34 and 3(1) (II) of SC/ST Act 1989	Case closed.	Hubballis-Dharwad city corporation	Smt Sahrantamma (wife)	UDR CASE- Case has not registered on POA 1989. No Rehabilitation detail given by DSW
28			Sri Ramesh	24 Year	SC (Lamaot)	Chamber, Near Old Ubbhalli Bhoreth Mill, Infront of Muneswara Guvi	10,00,000/-	-	10,00,000/-	-	136/2012 Dt: 22.07.2012 Old Hubli PS	IPC 1860 (U/s 304(a))	The accused face a maximum imprisonment of 6 month and a fine	Egal Infra India Ltd, Maharashtra	Smt Devakka Yammurappa Sri Ramesh bin Smt Devakka	UDR CASE- Case has not registered on POA 1989. No Rehabilitation detail given by DSW
29			Sri Saatosh	20 Year	SC (Lamaot)	10,00,000/-	-	10,00,000/-	-	-	-	-	-	-	-	-
30	2012-13	Shivmoga	Sri Annappa	48 Year	Dkkaliga	Royal Orcade Hotel, Shivmogg	10,00,000/-	-	10,00,000/-	-	375/2012 Dt: 23.11.2012 Doddepete PS	u/s 337, 339, 304(a) IPC 3(1)(a) the employment of manual scavengers & construction of drylatrus (Prohibition Act -1993)	Case has acquitted on 14.02.2019	Royal Orcade Hotel	Smt Lalitha (wife)	Case has not registered on POA 1989. No Rehabilitation detail given by DSW
31			Sri Rathnakara	34 Year	EEDIGA	10,00,000/-	-	10,00,000/-	-	-	-	-	-	-	Smt Lakshmi (wife)	
32	2012-13	Bengaluru Urban	Sri Shetakappa (Shankar)	30 Year	ST(Bedara)	Arakere, Bannerghatta Road.	10,00,000/-	-	10,00,000/-	-	330/2012 Dt: 14.07.2012 Hulimavu PS	IPC 1860 (U/s 304(a))	B' Final Report submitted on 09.08.2012	L&T Company	Smt Eshamma	Case has not registered on POA 1989. No Rehabilitation detail given by DSW
33			Sri Bhogan	-	-		10,00,000/-	-	10,00,000/-	-	-	-	-	-	-	Smt Peddapudi Padma & Smt Peddapudi Lakshmi (Both are wife)
54	2013-14	Mandya	Sri Rangaswamy	30 Years	SC (Andi Dravida)	Girija Slum Poure Karmika Colony, Mandya City, Beside Varalakshmi Military	10,00,000/-	-	10,00,000/-	-	108/2013 Dt: 01.04.2013 Mandya East PS	IPC 1860 U/s 304(a) r/w 34	The accused has been remanded and released on Bail	Social Welfare Dept, Mandya	Smt Lakshmi (wife)	Case has not registered on POA 1989.
35		Raichur	Sri Venkatesh	-	-	Davadurga, Raichur Dist.	10,00,000/-	-	10,00,000/-	-	UDR No. 06/2013 Dt: 02.05.2013 Davadurga PS	U/s 174 IPC	C' Report on 14.09.2005	MSKBR Infracon Ltd, Bangalore, KUIDFC	Smt Kotreshamma (wife)	UDR CASE- Case has not registered on POA 1989. No Rehabilitation detail given by DSW
36		Mysore	Sri Kumar	29 Year	SC (Aadi Dravida)	Infront of Kalpana Lodge, Mysore.	10,00,000/-	-	10,00,000/-	-	51/2014 Dt: 02.03.2014 Devaraja PS	U/s 304(a) IPC	Pending trial in court	Executive Engineer, Sewer Section, Mysore	Smt Geetha (wife)	Case has not registered on POA 1989. No Rehabilitation detail given by DSW
37	2013-14	Bengaluru Urban	Sri Prabadi Kumar	-	-	Vidyayagar, 5th Cross, Rajekaluve Chamber Nirmana, Bangalore Urban Dist.	10,00,000/-	-	10,00,000/-	-	675/2013 Dt: 25.10.2013 Peenya PS	U/s 304(a) IPC	Pending trial in Court.	BWSSB	Arjun Paswan (father) & Rajamani Davi (mother) Smt Sushela Devi (wife), Sri Shivacharanmochi (father)	No Rehabilitation detail given by DSW
38			Sri Robith Kumar	-	Chandravams hi	10,00,000/-	-	10,00,000/-	-	-	-	-	-	-	-	

True copy!!
87

The details of Manuai Scavengers who died while doing Manual Scavenging

Sl. No	Year	Dist Name	The name of the Manual Scavenger / Civil Worker who died while cleaning the Manhole/Septic Tank	Age	Caste & Sub Caste	Place of Incident occurred	The Compensation paid As per Supreme Court Judgment	The Compensation paid As per PDA	Total Compensation Given	Rehabilitation Details	FR Details		Case status Report	Departmental/Urban Local Bodies section/Corporation gives compensation	Name and Address of the Dependents	Remarks		
											FR No & Date	Section						
39		Hubli-Uharwad	Sri Hanumanta Varadappa	-	SC (Madar)	Hubballi Dbarwad	10,00,000/-	-	10,00,000/-		49/2015 Dt: 01.04.2015 Keshavapura PS Hubli	IPC 1860 U/s 304 r/w 34, The prohibition of employment as manual scavengers and rehabilitation act 2013 (U/s 5, 7, 8 & 9) & 3(2)(5) SC/ST Act 1989.	Released on 16.01.2018	Hubballi-Dharwad Municipal corporation	Smt Kavitha (wife)	No Rehabilitation detail given by DSW		
40			Sri Sufal Bisvas	-	SC (Madar)		10,00,000/-	-	10,00,000/-						Smt Sikha (wife)			
41		Hubli-Uharwad	Sri Krishna	32 Year	SC (Madar)	Kamadoli Village, Kundagol, Dharwad.	10,00,000/-	3,75,000/-	13,75,000/-	The wife of the deceased has been appointed to the post of 'D' Group at Kundagola Tehsiladar's office in Dharwad district.	43/2015 Dt: 05.05.2015 Kundagola PS	IPC 1860 U/s 304 The prohibition of employment as manual scavengers and rehabilitation act 2013 (U/s 5, 7, 8 & 9) & 3(2)(5) SC/ST Act 1989	Case has acquitted on 23.03.2016	ZP Dharwad	Smt Kasturamma Krishna Jalimara (Wife)	No Rehabilitation detail given by DSW		
42			Sri Marothi	35 Year	Gollar		10,00,000/-	-	10,00,000/-				ZP Dbarwad	Smt Nilava Gollar (Wife)				
43		Tumkur	Sri Chikkana	37 Year	SC (Adi Karnataka)	Saraswathipuram, 6th Cross, Tumkur Dist	10,00,000/-	-	10,00,000/-		211/2015 Dt: 28.11.2015 Tilakapark PS	IPC 1860 U/s 304 the prohibition of employment as manual scavengers and rehabilitation act 2013 (U/s 8 & 9)	Case has closed due to die of accused.	Tumkur Mahanagar Palike, Tumkur	Keerthana (Daughter)	Case has not registered on POA 1989. No Rehabilitation detail given by DSW		
44			Sri Narasimhamurthy	52 Year	SC (Adi Karnataka)		10,00,000/-	-	10,00,000/-					Smt Anjanamma (wife)				
45	2015-16	Bangaluru Urban	Sri Sridhar Manasabanna	20 Year	ST (Nayak)	Sarayipalya, Bangalore.	10,00,000/-	-	10,00,000/-		318/2014 Dt: 24.09.2014 Hennur PS	IPC 1860 U/s 304(a)	Pending trial in CC no: 51499/16	GKC Project Pvt (BWSSB)	Smt Jayamma (mother)	Case has not registered on POA 1989. No Rehabilitation detail given by DSW		
46				Sri Rajdimarappa	22 Year	ST (Nayak)		10,00,000/-	-	10,00,000/-		181/2015 Dt: 05.07.2015 Yelahanka New Town PS	IPC 1860 U/s 304(e)	Submitted 'B' Report on 12.03.2016	IVRCL (BWSSB)	Smt Sramadamma (mother) & M. D. Mokim (father)	No Rehabilitation detail given by DSW	
47				Sri Shamim Akhtar	19 Year	Musli	Attar Muneswara Extension, Yalahanka, Bangalore Urban Dist	10,00,000/-	-	10,00,000/-			IPC 1860 U/s 304(A), The Prohibition of Employment as Manual Scavengers and their Rehabilitation Act, 2013 (U/s-8, 9), 3 (2) (j) of the SCST Act 1989	Pending trial in Court	CPWD	Smt Shruthi, T.A W/o Prasanna Kumar	No Rehabilitation detail given by DSW	
48				Sri Shrangowda Pateel	23 Year	Ganiga (Lingayatha)		10,00,000/-	-	10,00,000/-						Smt Shivalingamma (mother)		
49				Sri Prasanna Kumar	24 Year	Okkaliga	JC Nagar, Jayamahal, 5th Main Road, Infront of CPWD housing, Bangalore Urban Dist.	10,00,000/-	-	10,00,000/-		155/2015 Dt: 16.08.2015 JC Nagar PS					Smt Sathyaraju W/o Sri Sundar	No Rehabilitation detail given by DSW
50				Sri Sothu Alias Suresh	21 Year	SC (Adi Karnataka)		10,00,000/-	-	10,00,000/-								
51				Sri Jagadish	23 Year	Okkaliga		10,00,000/-	-	10,00,000/-								
52				Sri Mahesh	22 Year	Nepalian	Royal Citadel Apartment, Beguru, Bangalore Urban Dist.	10,00,000/-	-	10,00,000/-		838/2015 Dt: 14.12.2015 Electronic City PS	IPC 1860 D/s 304(a)	Case closed on: 03.04.2018	Royal Citadel apartment owners Association, Manpal Count Road Singasandra, Bangalore	Sri N. Swamygowda (father)	Case has not registered on POA 1989. No Rehabilitation detail given by DSW	
53				Sri Renjan	22 Year	-		10,00,000/-	-	10,00,000/-							Smt Manjulatha (mother)	
54			2016-17	Bangalore Rural	Sri Madhu	21 Year	Dovanga		10,00,000/-	-	10,00,000/-	20*20 site has provided to Medhu Dependents.						Smt Lakshmi (mother)
55		Sri Muniraju			23 Year	SC (Aadi Dravida)	Khasabag, Doddaballapur, Bangalore Rural Dist.	10,00,000/-	-	10,00,000/-	Outsource Pournakarmika job has given to dependants of the Muniraju.	80/2016 Dt: 03.04.2016 Doddaballapur Town PS	IPC 1860 U/s 304(a), 3 clause 1(j) SC/ST Act 1989 and the prohibition of employment as manual scavengers and rehabilitation act 2013 (U/s: 5)	Pending trial in court as special case no: 262/2017.	City Municipal, Doddaballapura	Smt Doddanna (mother)	Compensation on POA not Given	
56		Sri Jagannatha			35 Year	SC (Bhovi)		10,00,000/-	-	10,00,000/-	Muniswamy & Jagannath are out of state so no rehabilitation given to their dependants.						Smt kakhmamma (wife)	
57		Sri Munirawamy			45 Year	Gowdar (Samanya)		10,00,000/-	-	10,00,000/-							Smt M. Vengamma (wife)	
58		Bangalore Urban	Sri Venkatesh	24 Year	SC (Bhovi)	RNS Shanti Nilas apartment, Tumkur Road, Bangalore Urban Dist.	10,00,000/-	-	10,00,000/-		402/2016 Dt: 16.10.2016 Yeshwanthpura PS	SC/ST Act 1989 (U/s-3(1)(i)); The Prohibition of Manual Scavenging and their Rehabilitation Act (U/s- 8, 9); IPC 1989 (U/s-304A).	Pending trial in CC no: 461/17	RNS Shanti Bivas Apartment, LNV Envira Engineer, Head Mohan Krishna	Smt Parvathamma (wife), Lakshmi Pura, Madhugiri Tq, Tumkur	No Rehabilitation detail given by DSW		
59			Sri Manjunath	52 Year	Lingayath		10,00,000/-	-	10,00,000/-						Smt Sulochana (mother)			

The details of Manual Scavengers who died while doing Manual Scavenging.

Sl. No	Year	Dist Name	The name of the Manual Scavenger/Civic Worker who died while cleaning the Manhole/Septic Tank	Age	Caste & Sub Caste	Place of incident occurred	The Compensation paid As per Supreme Court Judgment	The Compensation paid As per POA	Total Compensation Given	Rehabilitation Details	FIR Details		Case status Report	Department/Urban Local Bodies to whom Compensation given	Name and Address of the Dependents	Remarks
											FIR No. & Date	Section				
60	2017-18	Bengaluru Urban	Sri Anjaneya Reddy	35 Year	Reddy	No.74 Ward, 19th Road, Kaggadasapura Main Road, Bangalore.	10,00,000/-	-	10,00,000/-	-	40/2017 Dt. 07.03.2017 Byappanahalli PS	IPC 1860 (U/s-304) The Prohibition of employment as manual scavengers and their rehabilitation Act- 2013	Pending trial in City Court CC No. 52636/18	BWSSB	Smt K. Sri Devi (wife)	No Rehabilitation detail given by DSW
61			Sri Dantayarayya	35 Year	-	-	10,00,000/-	-	10,00,000/-	-	-	-	-	Smt Dantayarayamma (wife)		
62			Sri Tattatavittayya	40 Year	-	-	-	10,00,000/-	-	10,00,000/-	-	-	-	-	Smt Tatta Gannamma w/o Tatta Tavittayya	
63	2017-18	Bengaluru Urban	Sri Pruthviraj	24 Year	SC (Add Karnataka)	ECC Toad, Jatti Dwarakamayee Villa, Whitefield, Bangalore	10,00,000/-	-	10,00,000/-	-	197/2017 Dt. 25.05.2017 Whitefield PS	IPC 1860 (U/s 33B, 269, 304(a), 304(2)) The Prohibition of Manual Scavengers Act 2013 (U/s- 7,8,9) SC/ST Act (U/s- 3(1)(ii))	Pending trial in Court in CC No. 42/2018.	BBMP	Rukminamma (mother)	No Rehabilitation detail given by DSW
64			Sri Narayanaswamy	35 Year	Shettar	NDA Safal Apartment, HSR Layout, Bangalore.	10,00,000/-	-	10,00,000/-	-	06/2018 Dt. 07.01.2018 Bandepalya PS	IPC 1860 (U/s 304(a) r/w 34)	Pending for FSL report	BBMP	Smt Bharati & Radhamma	No Rehabilitation detail given by DSW
65			Sri H. Srinivas	58 Year	Oevanga	-	10,00,000/-	-	10,00,000/-	-	-	-	-	-	Smt Kamalamma & Lakshamma	
66			Sri Madegowda	42 Year	Okkaliga	-	10,00,000/-	-	10,00,000/-	-	-	-	-	-	Smt S.S. Manjula	
67			Sri Ramudu	-	SC	Hotel Yamlok, ABCS layout, Marthahalli.	10,00,000/-	-	10,00,000/-	-	48/2018 Dt. 13.02.2018 HAL PS	IPC 1860 (U/s 304 r/w 34), SC/ST Act 1989 (U/s- 3(1)(ii)) The Prohibition of Manual Scavengers Act 2013 (U/s-9)	Pending Trial in Court in CC No. 661/18	BBMP	Smt Jayamma (wife)	Compensation on POA not Given No Rehabilitation detail given by DSW
68	Sri Ravi	-	ST	-	10,00,000/-	-	10,00,000/-	-	-	-	-	-	Smt Maheshwari			
69	2018-19	Udupi	Sri Sandeep	22 Year	ST (Koraga)	Tekkatte Village, Kundapura Tq, Udupi Dist	10,00,000/-	8,25,000/-	18,25,000/-	0.09 Ecra sta has allotted. And action taken to grant house for the dependants of the family, and other rehabilitation action has been under progress.	53/2018 Dt. 07.04.2018 Kundapura PS	IPC 1860 (U/s 304A), SC/ST Act 1989 (U/s- 3(1)(ii)) The Prohibition of Manual Scavengers Act 2013 (U/s-4)	Tending trial SC No. 35/2018 on: 24.02.2020.	Purasabhe & Social Welfare Dept. Kundapura	Sri Santosh (Elder Brother), Sangeetha (Younger Sister), Prabhakar (Younger Brother)	-
70	2018-19	Davangere	Sri Anjinappa Bin Murthy V	17 Year	SC (Bhevi)	UDD Manhole Beside New Mandli Nagarahalli Gas Agency, Davangere.	10,00,000/-	4,12,500/-	14,12,500/-	Proposal has sent for CG Basis appointment to the dependants of the family.	493/2018 Dt. 06.08.2018 Doddapete PS	IPC 1860 (U/s-304); The Scheduled Tribes (Prevention of Atrocities) Amend ment Bill, 2015 (U/s-3(1)(i)); The Prohibition of Employment as Manual Scavengers and their Rehabilitation Act, 2013 (U/s-7,8)	Pending trial in Court as special case no: (C)192/19 on: 03.03.2020.	Devanagere Mabanagere Palithe	Sri Murthy V bio Veerappa	-
71			Sri Venkatesh Bin Swamy	35 Year	SC (Bhovli)	-	10,00,000/-	4,12,500/-	14,12,500/-		-	-	-	-	-	Smt Manjamma (wife)
72	2018-19	Bengaluru Urban	Sri Manu	27 Year	Lingayatha	Hongasandra Jai Hindy International School.	10,00,000/-	-	10,00,000/-	-	30/2018 10.02.2018 Begur PS	The Prohibition of Employment as Manual Scavengers and their Rehabilitation Act, 2013 (U/s-9); IPC 1860 (U/s-34,304(A))	Chargesheet has been Prepared	R3MP	Smt Nandini (wife), Smt Ningamma (mother)	No Rehabilitation detail given by DSW
73	2018-19	Vijaypur	Nabilal Rahimansab Ekkevala	26 Year	Muslim	Amar International Hotel, Indl, Vijaypura Dist.	10,00,000/-	-	10,00,000/-	Proposal has sent to UC for rehabilitation of dependants	035/2019 Dt: 02.04.2019 Vijaypur Indl PS	SC AND P (PREVENTION OF ATROCITIES) ACT, 1989 (U/s-3(2)(S)); The Prohibition of Employment as Manual Scavengers and their Rehabilitation Act, 2013 (U/s-5(1)(B)); IPC 1860 (U/s-304,34)	Case is under investigation	Purasabhe Indl	Basira Nabilela Ekkevala	-
74			Lalappa Somanna Madara	45 Year	SC(Madara)		10,00,000/-	1,50,000/-	11,50,000/-						Yallappa Lalappa Madara	
75			Budasab Khadasab Bhagavan	35 Year	Muslim		10,00,000/-	-	10,00,000/-						Mehabooch Gudasab Bhagawan	
76	2018-19	Bengaluru Urban	Cafoor Pasha	45 Year	Muslim	Dismilla Tea hotel, Nagavara Main Road, KG Halli, Bangalore Urban Dist.	10,00,000/-	-	10,00,000/-	-	0156/2019 Dt. 27.04.2019 Kadagondana Halli PS	The Prohibition of Employment as Manual Scavengers and their Rehabilitation Act, 2013 (U/s-8,9); IPC 1860 (U/s-304-B)	Under investigation (SFL Report)	BBMP	Haseena Banu	-
77			Aptab Pasha @ Chotu	38 Year	Muslim	-	10,00,000/-	-	10,00,000/-	-	-	-	-	-	Hifun Sulthana	

The details of Manual Scavengers who died while doing Manual Scavenging

Sl. No	Year	Dist Name	The name of the Manual Scavenger/Chic Worker who died while cleaning the Manhole/Sepetic Tank	Age	Caste & Sub Caste	Place of Incident occurred	The Compensation paid As per Supreme Court Judgement	The Compensation paid As per PDA	Total Compensation Given	Rehabilitaion Details	FIR Details		Case status Report	Department/Urban Local Organi- sation/Corporation given compensation	Name and Address of the Dependans	Remarks
											FIR No & Date	Section				
76	2019-20	Karwar-UK	Sri B. Kotayya	-	SC	Abhimanshree Apartment, Ramakrishna sshrama Road, Karwar, UK Dist	10,00,000/-	4,12,500/-	14,12,500/-	1) Proposal has sent to DC, UK for CG Basis appointment to the dependants of the family. 2) As per the direction of the DC, victim's family will be considered for Gruhabhagya Scheme.	0071/2019 Dt. 11.08.2019 Karwar Town PS	SC AND THE ST (PREVENTION OF ATROCITIES) ACT, 1989 (U/s-3(2)(5)); IPC 1860 (U/s-304(A))	Case is under Investigation	CMC Karwar & DSW UK(Karwar)	Dhanamma Kottayya Budhaal (Wife)	No Rehabilitation detail given by DSW
79		Bengaluru Urban	Sri Siddappa	20 Year	Kuruba	Premise of S.S.B.S Jain Singh Trust, Infantry Road, Bengaluru-01	10,00,000/-	-	10,00,000/-	-	0013/2020 Dt: 25/01/2020 Commercial Street PS	IPC 1860 (U/s 34, 304, 338), SC and ST (Prevention of Atrocities) Act, 1989 (U/s-3(1)(i)) and The Prohibition of Employment as Manual Scavengers and their Rehabilitation Act, 2013 (U/s 7, 8, 9)	Case is under Investigation	BDMP	Shankaramma (Mother)	No Rehabilitation detail given by DSW
80			Sri Muniyanna	50 Year	SO (Bhovf)		10,00,000/-	4,12,500/-	14,12,500/-	-						
81		Mysore	Sri Murugan	36 Years	SC (Adi Dravida)	At Maragowdhanahalli village open Street drainage, to pura tg, Mysuru Dist.	10,00,000/-	-	-	-	0095/2020 Dt: 06/06/2020 Bannur PS	IPC 1860 (U/s-304)	Case is under Investigation	-	Smt Priya (wife) 7624841407	-
82		Bengaluru Urban	Sri jems	22 Years	SC	POLOMA TURNING COMPANY, Bandanpura (V), Attibele (ri), Anekal Tq, Bengaluru Dist.	10,00,000/-	-	10,00,000/-	-	0111/2020 Dt: 09/06/2020 Suryanagar PS	IPC 1860 (U/s-337,304(A))	Case is under Investigation	POLOMA TURNING COMPANY	Rejendran (Father)	-
83			Sri Ananda	32 years	Kuruba		[job in the same company to wife of the Anand, Free Education to children of Anand.	10,00,000/-	-	10,00,000/-					-	Remakrishnappa (Father) Mob No: 959109334
84	2020-21	kalburgi	Sri Lal Ahmad	36 Years	Muslim	Kallasha Nagara, Mahalakshmi Layout, Kalburgi	10,00,000/-	-	10,00,000/-	1) House Sanctioned to Deceased Dependent. (Survey No. 21/1, Block 1, House No. 709) 2) Scholarship Sanctioned to Deceased Dependent. 3) Loan Sanctioned to Deceased Dependent 4) Deceased person wife has got job in KUWSDI under out source (Group-D)	0014/2021 Dt. 28/01/2021, Ragavendra PS	IPC 1860 (U/s-304(A) AND MS ACT-2013 (U/s, 8,9)	Chargesheet has submitted.	KUWSDB	Smt. Asma Begum (Wife)	-
85			Sri Rasheed Shek	34 Years	Muslim		10,00,000/-	-	10,00,000/-	1) House Sanctioned to Deceased Dependent. (Survey No. 21/1, Block 1, House No. 710) 2) Scholarship Sanctioned to Deceased Dependent. 3) Loan Sanctioned to Deceased Dependent 4) Deceased person wife has got job in KUWSDB under out source (Group-D)					Smt. Tabsama Begum (Wife)	
86		RAMANAGARA	Sri Manjunath	32 Years	SC (ADI KARNATAKA)	BEHIND AFMC MARKET (Near Nethaji Popular School), Ramanagara	10,00,000/-	8,25,000/-	18,25,000/-	1) Scholarship Sanctioned to Deceased Dependent. 2) Loan Sanctioned to Deceased Dependent	0036/2021 Dt: 04/06/2021, JODOR PS	IPC 1860 (U/s 34, 304-II, 204), SC and ST (Prevention of Atrocities) Act, 1989 (U/s-3(1)(i)) and The Prohibition of Employment as Manual Scavengers and their Rehabilitation Act, 2013 (U/s-5,6,7,8)	Under Investigation (SPL Report)	City Municipal Council, Ramanagara	Smt. Anitha (Wife)	-
87	2021-22		Sri Rajesh	29 Years	KUMBARA SHETTY		10,00,000/-	-	10,00,000/-	1) Scholarship Sanctioned to Deceased Dependent. 2) Loan Sanctioned to Deceased Dependent					Smt. Muthulakshmi (Wife), Smt. Lakshamma (Mother), K: Sharanya R (Daughter)	
88			Sri L. Manjunath	30 Years	KURUBA		10,00,000/-	-	10,00,000/-	1) Scholarship Sanctioned to Deceased Dependent. 2) Loan Sanctioned to Deceased Dependent					Smt. Nagamma (Wife)	

//True copy//
90

The details of Manual Scavengers who died while doing Manual Scavenging

Sl. No.	Year	Dist Name	The name of the Manual Scavenger/Child Worker who died while cleaning the Manhole/Septic Tank	Age	Caste & Sub Caste	Place of Incident occurred	The Compensation paid As per Supreme Court Judgment	The Compensation paid As per POA	Total Compensation Given	Rehabilitation Details	FIR Details		Case status/Report	Department/Urban Local Organisation/Corporation gives compensation	Name and Address of the Dependents	Remarks
											FIR No & Date	Section				
89		Bengaluru Urban	Sri. Mohan	17 Years	Adi Karnataka	Bengaluru, Chinnaswamy Stadium, Gate No.6	10,00,000/-	-	10,00,000/-		0197/2021 Dt: 24.11.2021, commercial	JuvenH Justice (Case and Protection of Children) Act, 2015, (U/s-8,98), IPC 1860 (U/s- 34,304)	Under investigation	Navodaya Company	sri.vardappa H	
90		Mysore	Sri Madhu		Adi Karnataka	Periyapatna, Mysuru	10,00,000/-	4,12,500/-	14,12,500/-		0331/2021, Dt: 18.12.2021, Periyapatna	WS Act,2013 (U/s- 3,8,9)	Under investigation	City Municipal Council and Social welfare Department	sri.Abhiramf	
91	2022-23	Bengaluru Urban	Sri Dileep Kumar jena	24 Year	SC	Prestige Falcon City Apartment Complex, STP Tank, Kanakapura Road, Bengaluru.	10,00,000/-	-	10,00,000/-		0045/2023 Dt: 05.02.2023, Bengaluru	IPC 1060 (U/s-304(A))	Under Investigation	Prestige Falcon City	Sri. Ohngabot Jena	
92			Sri Ravi Kumar	39 Year	Golla		-	-	-						Smt. Shashikala	Deceased Family members have filed a case before Hon'ble Principal Senior Civil Judge and JMC, Madhugiri(Taluk), Tumakuru (Dist) in case No.E.C.A/3000002/2023 against M/s. Prestige Falcon City Apartments seeking compensation of Rs.80,00,000/-.

//True copy//
16 //True copy

Annexure IV-E

GOVERNMENT OF MANIPUR
SECRETARIAT: MAHUD DEPARTMENT

NOTIFICATION
Imphal, the 29th December 2023.

No. MiscM-601/9/2020-MAHUD-MAHUD: Whereas, Hon'ble Supreme Court of India vide their Judgement dated 20.10.2023 in the Writ Petition(Civil) No. 324 of 2020 (*Dr. Balram Singh -vs- Union of India & Ors*) directed to ensure for setting up of State level Commission or designate any authority in this behalf in the States/UTs in a time bound manner;

2. And whereas, Secretary, National Commission for Safai Karamcharis, Ministry of Social Justice & Empowerment, Govt. of India vide his D.O.No.1 1059/06/2017/R&D dated 21.10.2023 addressed to Chief Secretary, Government of Manipur also directed to constitute a State Level Commission for Safai Karamcharis or designate any other authority to perform the function of the Commission as per the provisions of Section 32(1) of "Prohibition of Employment as Manual Scavengers and their Rehabilitation Act, 2013"

3. Now, therefore, In compliance with the aforesaid directions, the Governor of Manipur hereby designates Director, Municipal Administration, Housing and Urban Development (MAHUD), Manipur to perform the function of the State Level Commission as per the provisions of Section 32(1) of "Prohibition of Employment as Manual Scavengers and their Rehabilitation Act 2013" with immediate effect and until further orders.

This is issued with the approval of Competent Authority.

By orders & in the name
of the Governor

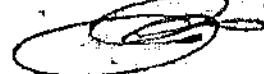

(K. Bono Singh)
Additional Secretary (MAHUD),
Government of Manipur.

Copy to:

1. Secretary, National Commission for Safai Karamcharis, Ministry of Social Justice & Empowerment, Govt. of India [E-mail: secy-ncsk@gov.in]
2. Staff Officer to Chief Secretary, Government of Manipur.
3. Commissioner (MAHUD), Government of Manipur.
4. Director (MAHUD)/(Social Welfare)/(SC & OBC), Manipur.
5. **Shri S.K. Srivastwa**, Deputy Secretary, Ministry of Social Justice & Empowerment, Govt. of India [E-mail: srivastwa.sk@nic.in]
6. Deputy Commissioner/DM of all Districts in Manipur.
7. Director, Printing & Stationery, Manipur with a request to publish the above Notification in the Extra-ordinary Gazette of Manipur and furnish 30(thirty) copies to this Department.
8. **Shri Ramesh Pukhrambam**, State Government Standing Counsel in

GOVERNMENT OF MEGHALAYA
SOCIAL WELFARE DEPARTMENT

No SW (S) 105/2022/184

Dated Shillong the 29th December, 2023

From: Shri I W Ingty, IAS,
Secretary to the Govt. of Meghalaya,
Social Welfare Department

To,

Sh. S.K. Srivastawa,
Deputy Secretary to the Govt. of India
Ministry of Social Justice and Empowerment
Government of India
B-2, Ground Floor,
Pt. Deendayal Antyodaya Bhawan,
CGO Complex,
New Delhi -110014

Subject: Writ Petition (Civil) No. 324 of 2020 titled as Dr. Balram Singh v. Union of India &
Ors. Judgment dated 20.10.2023 - compliance regarding

Ref.: Your letter No. U-12021/1/2023-PLAN dated 14th November, 2023 on above subject

Sir,

In reference to your letter dated 14.11.2023 on the above subject, I am directed to state that the State of Meghalaya is compliant with the directions passed by the Hon'ble Supreme Court in its judgment dated 20.10.2023, information regarding which is being submitted hereunder:

1. In compliance with the provisions of the Prohibition of Employment as Manual Scavengers and their Rehabilitation Act 2013 and the Rules framed thereunder, the practice of manual scavenging has been completely abolished in the State of Meghalaya and as informed earlier there are no manual scavengers in the state of Meghalaya after 2014.
2. The guidelines which will be issued by the Government of India, as directed by the Hon'ble Supreme Court shall be accommodated in the rules/regulations and bye-laws of all the municipal bodies and authorities in the State of Meghalaya.

93
TRUE COPY
S

3. There is no sewerage system in the State of Meghalaya and hence there is no question of any death or disablement of sewage workers in the State of Meghalaya. Insofar as the cleaning of septic tanks are concerned it is being done by the workers of different municipal authorities in the state of Meghalaya and till date there is no death or disablement which has taken place. Hence, the issue of payment of compensation, grant of employment to the next of kin, education and skill training to the dependents or that of ensuring any accountability on any person does not arise in state of Meghalaya.
4. The State of Meghalaya has already established different authorities at state level and district level as required under the Prohibition of Employment as Manual Scavengers and their Rehabilitation Act 2013 and rules framed thereunder, details of which is as follows:
- i. **State Safai Karmacharis Commission**- The setting up of the State Safai Karmacharis Commission /Designation of an Agency to work as State Safai Karmacharis Commission under Section 32 of the Act of 2013 to perform the function of the Commission as prescribed under Section 31(1) of the said Act is under examination by the State Government.
 - ii. **State Monitoring Committee:** The State Government has constituted the State Monitoring committee vide notification No. UAU.64/2006/483 dated 03.04.2018. *(Copy enclosed)*
 - iii. **District Vigilance Committee & Sub-Division Level Survey Committee:** The State Government has constituted the District Vigilance committee and the Sub-Division Level Survey Committee vide notification No. UAU.64/2006/482 dated 03.04.2018. *(Copy enclosed)*
 - iv. **State Level Survey Committee:** The State Government has constituted the State Level committee vide notification No. UAU.30/2005/377 dated 21.05.2013. *(Copy enclosed)*
5. Upon promulgation of the Act of 2013 and directions of Ministry of Social Justice and Empowerment, Government of India a survey of all 13 municipal towns was conducted in the year 2013-2014 and no manual scavengers were found in the State of Meghalaya which report was submitted to the Ministry of Social Justice and Empowerment, Government of India vide letter dated 21.08.2013. *(Copy enclosed)*

//True copy,

6. Accordingly, a notification was issued by the Government of Meghalaya on 21.04.2014 declaring the 10 statutory municipal towns as free from manual scavenging and dry latrines. (Copy enclosed)
7. The details of the nodal office dealing with the issue of Safai Karmaeharis in the Social Welfare Department of Government of Meghalaya is as follows:

Directorate of Social Welfare,

Lower Lachumiere,

Shillong 793 001.

Contact Number: Smti C D Lyngwa, MCS,

Director of Social Welfare

90890-61200

Email I/D: directorsw-meg@gov.in

8. The State of Meghalaya is fully compliant with the directions issued in the judgement of Hon'ble Supreme Court in the case of Writ Petition (Civil) No. 324 of 2020 titled as Dr. Balram Singh v. Union of India & Ors. dated 20.01.2023. The status of complianee regarding State of Meghalaya, as detailed above, make kindly be placed before Hon'ble Supreme Court do as directed in the set judgement.

This has the approval of the "Competent Authority"

Thanking you.

Yours faithfully,

Secretary to the Govt. of Meghalaya,
Social Welfare Department

Enclosures: As above

//True copy//

95

Memo No SW (S) 105/2022/184 -A

Dated Shillong the 29th December, 2023

Copy to :-

1. The Private Secretary to the Principal Secretary to the Govt. of Meghalaya, Social Welfare Department for kind information of the Principal Secretary.
2. The Private Assistant to the Commissioner & Secretary to the Govt. of Meghalaya, Social Welfare Department for kind information of the Commissioner & Secretary.

By Orders Etc,

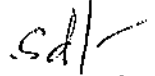

Secretary to the Govt. of Meghalaya,
Social Welfare Department

//True copy//

96

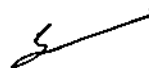

GOVERNMENT OF MEGHALAYA
URBAN AFFAIRS DEPARTMENT

NOTIFICATION

Dated Shillong, the 3rd April, 2018

No.UAU.64/2006/483- In exercise of powers conferred under Sec. 26 of the Prohibition of Employment as Manual Scavengers and their Rehabilitation Act, 2013, the Governor of Meghalaya is please to constltute a State Monitoring Committee with the following members for ensuring that the provision of the Aet or any rule made there under are properly implemented with effect from the date of issue of this notification .

1.	The Chief Minister Government of Meghalaya or a Minister nominated by him	- Chairperson, Ex-Officio
2.	Representative of the National Commission for Schedule Caste and Safai Karamcharis	- Member Ex- Offi
3.	MLA of North Shillong Constituency & MLA of South Shillong Constituency.	- -do-
4.	The Director General of Police Meghalaya, Shillong	- -do- Ex-Officio
5.	Secretary, Home Police Department / Social Department	- -do-
6.	Chief Exeective Officer of all the Municipal Boards and Cantonment Board.	- -do-
7.	Not more than four social worker belonging to organization working for the prohibition of manual scavengers representing the scavenger community to be nominated by the Govt. two of whom shall be women.	- -do-
8.	State Level head of the convener Bank of the State Level Bankers Committee.	- -do- Ex-Officio
9.	Principal Secretary/ Commissioner Secretary Urban Affairs Department.	- Member Sec Ex-Officio
10.	Representative of other department of the State Govt. and such other agencies in which in the opinion of the State Govt. are concerned with the implementation of this Act.	- Member

Term of Reference:-

- To monitor and advice the State Government and local authorities for effective implementation of the Act.
- To co-ordinate the functions of all concerned agencies.
- To look into any other matter incidental thereto or connected therewith for implementation of the Act.

Office of the Director

Sd/-
(D.P. Wahlang) IAS,

True copy//
97

memo.No.UAU.64/2006/483 - A

Dated Shillong, the 3rd April, 2018.

Copy to:-

1. The P.S to Hon'ble Chief Minister for favour of Information of Chief Minister.
2. MLA of South Shillong Constituency and North Shillong Constituency.
3. The P.S to Chief Secretary for favour of information of Chief Secretary.
4. P.A to Principal Secretary to the Gov. of Meghalaya, Urban Affairs Department for favour of information of Principal Secretary.
5. Director Urban Affairs, Meghalaya Shillong.
6. All member concerned.

By order etc.,

Under Secretary to the Govt. of Meghalaya,
Urban Affairs Department.

//True copy//

GOVERNMENT OF MEGHALAYA
URBAN AFFAIRS DEPARTMENT

NOTIFICATION

Dated, Shillong, the 3rd April, 2018

No. UAU.64/2006/482- In exercise of powers conferred under Sec.24 of the Prohibition of Employment as Manual Scavengers and their Rehabilitation Act, 2013, the Government of Meghalaya is please to constitute a Vigilance Committee at the District Level and Sub-Divisional Level with the following members with immediate effect and until further order for ensuring that the provision of the Act or any rule made there under are properly implemented with effect from date of issue of this notification.

- | | |
|------------------------------------------------------------------------------------------------------------------------------------------------------------------------------------------------------------------------------------------|---------------------------|
| 1. Deputy Commissioner of respective District | - Chairman, Ex- |
| 2. Two members of the State Legislature elected from the District. | - Member |
| 3. Superintendent of Police of respective District | - -do- |
| 4. The Chief Executive Member of respective District Council | - -do- |
| 5. The Chief Executive Officer, Shillong Municipal Board/
Cantonment Board. | - -do-Member
Secretary |
| 6. Four Social worker belonging to organization working for the
prohibition of Manual soavenging or representing the
Scavenger Community, two of whom shall be women. | - -do- |
| 7. One person to represent the financial and credit institution in
the District to be nominated by the District Magistrate. | - -do- |
| 8. District Level Officer of department and agencies who in the
opinion of the District Magistrate subject to General Orders, if
any of the State Government have a significant roie to play in
the implementation of this act. | - -do- |

Sub- Divisional Level

- | | |
|------------------------------------------------------------------------------------------------------------------------------------------------------------------------------------------------|----------------|
| A. The Sub-Divisional Magistrate of respective Sub- Division | - Chairperson, |
| B. Chair person from the two Panchayats at village level to be
nominated by the S.D.O | - Member |
| C. The Sub-Divisional Officer of Police | - -do- |
| D. The Chief Executive Office of | - -do- |
| i. The Municipality / Town Committee of the Sub-
Divisional headquarter or Executive Engineer, PHE,
in subdivision where there is no Town Committee or
Municipal Boards. | - Member Sei |
| ii. Cantonment Board if any situated in the sub-
division | - -do- |
| E. Two social workers belonging to the organisation working for
the prohibition of Manual Scavenging and rehabilitation of the
manual scavengers or representing the scavenger community | - -do- |

//True copy//

long wit
compe

he num

- F. One person to represent the financial and credit institution in the sub-division to be nominated by the sub-divisional magistrate. - -do-
- G. Sub-divisional Level Officers of department and agencies who in the opinion of the sub-divisional magistrate subject to any general order of the State Govt. or the Sub-Divisional Magistrate have a significant role to play in the implementation of the act. - -do-

Term of Reference:-

1. Each vigilance Committee constituted at district and sub-district level shall meet least once in every three months.
2. To advise the District Magistrate or the sub-divisional Magistrate on the action which needs to be taken to ensure that the provision of the Act or any rule made there under are properly implemented.
3. To oversee the economic and social rehabilitation of manual scavenger.
4. To co-ordinate the functions of all concerned agencies with a view to channel adequate credit for the rehabilitation of manual scavengers.
5. To monitor the registration of offices under this Act and their investigation and prosecution.

Sd/-
(D.P. Wahlang) IAS,
Principal Secretary to the Govt. of Meghalaya
Urban Affairs Department.

Memo.No.UAU.64/2006/482 - A

Dated Shillong, the 3rd April, 2011

Copy to:-

1. The P.S to Hon'ble Chief Minister for favour of information of Chief Minister
2. The P.S to Chief Secretary for favour of information of Chief Secretary.,
3. P.A to Principal Secretary to the Govt. of Meghalaya, i/c Urban Affairs Department for favour of information of Principal Secretary .
4. Director Urban Affairs, Meghalaya Shillong.
5. All member concerned.

By order etc.,

Under Secretary to the Govt. of Meghalaya,
Urban Affairs Department.

//True CC

GOVERNMENT OF MEGHALAYA
URBAN AFFAIRS DEPARTMENT

(15)

Notification

Dated Shillong, the 21st May, 2013.

No: UAU. 30 / 2005 / 377 : For purpose of monitoring the survey of manual scavengers and insanitary toilets in Meghalaya, the state level Survey committee is hereby constituted with the following members.

- 1. Principal Secretary, Urban Affairs Department ----- Chairman
- 2. Joint Secretary, Urban Affairs Department ----- Member
- 3. Director, Urban Affairs, ----- Member Secretary
- 4. Joint Director, Urban Affairs, ----- Member

P Naik
(P Naik)

Principal Secretary
Urban Affairs Department.

Dated Shillong, the 21st May, 2013.

Memo: No: UAU. 30 / 2005 / 377-A,

Copy to:

All members

J

Joint Secretary
Urban Affairs Department.

JD
HC
877
RA
H
M
877

Office of the Secretaries of
Urban Affairs Department, Shillong

Receipt No. *8343*

Date *9.7.13*

//True copy//

ANNEXURE - IV

1237

GOVERNMENT OF MEGHALAYA
URBAN AFFAIRS DEPARTMENT

No: UAU. 30 / 2005 / 448,

Dated Shillong, the 21st August, 2013.

To,

Mukat Singh
Deputy Director General
Government of India,
Ministry of Social Justice & Empowerment,
West Block-8, RK Puram, New Delhi-110066

Subject : Survey of Manual Scavengers and unsanitary latrines : Submission of report thereof.

Reference :- DO No.4-2/2012-PREM(SCD), dt. 07/08/2013

Sir,

With reference to the above, I am directed to furnish herewith the Final report as per Form SF-FV for your information and necessary action.

Yours faithfully

(T Lyngwa)
Joint Secretary
Urban Affairs Department.

Memo No: UAU. 30 / 2005 / 448-A,

Dated Shillong, the 21st August, 2013.

Copy to :-

1. The Director, Urban Affairs, Govt, of Meghalaya.
2. The State Informatic Officer, NIC Meghalaya, with a request to kindly upload the report in the website.

//True copy//

Joint Secretary
Urban Affairs Department.

102

Office of the Joint Secretary
Urban Affairs Department, Shillong
Reference No: 11420-21
Date: 27-8-13

J.P.
27/8

R.A.
M.

27/8

List of Manual Scavengers in the State/UT

Name of the State : Meghalaya

Sl No.	District	City/Town	Name of the Manual Scavenger	Name of Father/Husband	Address	Remarks (If any)
1	2	3	4	5	6	7
1.	East Khasi Hills	Shillong Municipal Board	NIL	NIL	NIL	
		Shillong Cantonment Board	NIL	NIL	NIL	
2	West Khasi Hills	Nongstoin Town Committee	NIL	NIL	NIL	
		Mairang Town Committee	NIL	NIL	NIL	
3.	Ri-Bhoi District	Nongpoh Town Committee	NIL	NIL		
4.	Jaintia Hills	Jowai Municipal Board	NIL	NIL		
5.	West Garo Hills	Tura Municipal Board	NIL	NIL	NIL	
6.	Est Garo Hills	Willaim Nagar Municipal Board	NIL	NIL	NIL	
7.	South Garo Hills	Baghmara Municipal Board	NIL	NIL	NIL	
8.	North Garo Hills	Resubelpara Municipal Board	NIL	NIL	NIL	

File No. UAU.30/2005/448

Date: Shillong, the 20th August 2013.

Forwarded to Deputy Director General (Statistics)
M/o Social Justice & Empowerment, West Block-8,
R. K. Puram, New Delhi- 110066.

//True copy//

Signature 

Name & Designation of Nodal Officer

L. Lyngma

GOVERNMENT OF MEGHALAYA
URBAN AFFAIRS DEPARTMENT.

NOTIFICATIONDated Shillong, the 21st April, 2014.

No. UAU.30/2005/129 - The Governor of Meghalaya is pleased to notify the following towns of the State 6 (six) Municipal Boards 1 (one) Cantonment and 3 (three) Town Committee as free from Manual Scavengers and dry Latrines.

<u>District</u>	<u>City/Town</u>
East Khasi Hills	<u>Shillong Municipal Board</u>
	Shillong Cantonment Board
West Khasi Hills	<u>Nongstoin Town Committee</u>
	Mairang Town Committee
Ribhoi District	Nongpoh Town Committee
Jaintia Hills	Jowai Municipal Board.
West Garo Hills	Tura Municipal Board.
East Garo Hills	Williamnagar Municipal Board.
South Garo Hills	Baghmara Municipal Board.
North Garo Hills	Resubelpara Municipal Board.

M. J. J.
Under Secretary to the Govt. of Meghalaya
Urban Affairs, Department.

No. UAU. 30/2005/129 -A

Dated Shillong, the 21st April, 2014.

to:-

1. P.S. to Chief Minister, for favour of information of Chief Minister.
2. P.S. to Minister, Urban Affairs for favour of information of Minister.
3. P.S. to Chief Secretary, for favour of information of Chief Secretary.
4. The Director, Urban Affairs, Meghalaya, Shillong.
5. The Deputy Commissioner, East Khasi Hills.
6. The Deputy Commissioner, West Khasi Hills.
7. The Deputy Commissioner, West Jaintia Hills.
8. The Deputy Commissioner, Ribhoi District.
9. The Deputy Commissioner, East Garo Hills District.
10. The Deputy Commissioner, West Garo Hills District.
11. The Deputy Commissioner, South Garo Hills District.
12. The Deputy Commissioner, North Garo Hills District.
13. The Chief Executive Officer, Shillong Municipal Board.
14. The Chief Executive Officer, Jowai Municipal Board.
15. The Chief Executive Officer, Tura Municipal Board.
16. The Chief Executive Officer, Williamnagar Municipal Board.
17. The Chief Executive Officer, Baghmara Municipal Board.
18. The Chief Executive Officer, Resubelpara Municipal Board.
19. The Chief Executive Officer, Shillong Cantonment Board.
20. The Sub Divisional Officer (Civil) Mairang Civil Sub Division

Office of the Director of Urban Affairs, Shillong.

U

f

Date

5750

29.4.14

True copy

104

By order etc.,

44-2
1/2/14
27/4/14

Provision of the MS Act, 2013 requiring action by State Govts. Are:

Sf No	Section of MS Act	Action to be taken by State Govts.	Action Taken
1.	4	<ul style="list-style-type: none"> • Survey of Insanitary Latrines • Construction of Sanitary Committee 	Survey was conducted on 2013 and it was found to be nil. This was intimated to the Ministry of Social Justice & Empowerment.
2.	13	<ul style="list-style-type: none"> • Issue photo identity card to identify Manual Scavengers • Provide residential plot and financial assistance for house construction or a ready-built house • Provide Scholarship to children of MS 	Does not arise in view of the above.
3.	17	<ul style="list-style-type: none"> • Responsibility of energy local authority to ensure, through awareness campaign etc that <ul style="list-style-type: none"> • No Insanitary latrine is constructed, maintained or used • In case of contravention of above action is taken against the occupier 	Complied
4.	18	<ul style="list-style-type: none"> • Confer power and imposed duties on local authority and District Magistrate to ensure that the provision of the Act are carried out 	Complied
5.	19	<ul style="list-style-type: none"> • DM or authorized authority to ensure that: - <ul style="list-style-type: none"> • No person is engaged or employed as Manual Scavengers • No one construct, maintains, uses insanitary latrines • Identified MS are rehabilitated • Persons contravening the provision of Section 5,6 or 7 are investigated and prosecuted under the provision of this Act 	Complied
6.	20	<ul style="list-style-type: none"> • Appointment of inspectors under the Act 	Complied
7.	21	<ul style="list-style-type: none"> • Confer power of Judicial Magistrate of first class, on an Executive Magistrate, for the trial of offenses under the Act 	Complied
8.	24	<ul style="list-style-type: none"> • Constitute vigilance committee for each district and sub-division 	Complied
9.	26	<ul style="list-style-type: none"> • Constitute State monitoring committee 	Complied
10.	28	<ul style="list-style-type: none"> • Send periodic reports to the Central Government as the Central Government may require 	Complied

//True copy"

11.	32	• Designate a State Commission for Safai Karamchari	Action to be taken By Social Welfare Department
12.	33	• Duty of every local authority and other agency to use modern technology for cleaning of sewers and septic tanks	Complied

Direction SI No	Direction of Hon'ble Supreme Court	Action by	Action taken																		
II.	Steps taken towards abolition/demolition of Dry Latrines, state-wise	All State/UTs/Ministries/ Depts. Of HUA, DWS	Does not arise in view of the findings conducted by the Survey in 2013 as highlighted at point 1																		
III.	Status of Dry Latrines and Safai Karmacharis in Cantonment Boards and Railways.	M/o Defense/Railways																			
IV.	Employment of Safai Karmacharis in Railways and Cantonments Boards whether directly or indirectly i.e through Contractors or otherwise.	M/o Defense/Railways																			
V.	State-wise set up of Municipal Corporation and the nature of equipment (as well as the description of technical equipment), deployed by such bodies to mechanize sewage cleaning.	All State/UTs MoNUA	<table border="1"> <thead> <tr> <th>S/No</th> <th>Type</th> </tr> </thead> <tbody> <tr> <td>a)</td> <td>Super Sucker (incl Sewer Jetting apparatus)</td> </tr> <tr> <td>b)</td> <td>Septic Tank Suction/ Desilting app</td> </tr> <tr> <td>c)</td> <td>Manhole Desilting/ Grabbing app</td> </tr> <tr> <td>d)</td> <td>Sewer Inspection Cametas Appar</td> </tr> <tr> <td>e)</td> <td>Sewer Bucket Apparatus (Nallah</td> </tr> <tr> <td>f)</td> <td>Rodding Machines</td> </tr> <tr> <td>g)</td> <td>Jetting Machines</td> </tr> <tr> <td>h)</td> <td>Sewer Croc Apparatus</td> </tr> </tbody> </table>	S/No	Type	a)	Super Sucker (incl Sewer Jetting apparatus)	b)	Septic Tank Suction/ Desilting app	c)	Manhole Desilting/ Grabbing app	d)	Sewer Inspection Cametas Appar	e)	Sewer Bucket Apparatus (Nallah	f)	Rodding Machines	g)	Jetting Machines	h)	Sewer Croc Apparatus
S/No	Type																				
a)	Super Sucker (incl Sewer Jetting apparatus)																				
b)	Septic Tank Suction/ Desilting app																				
c)	Manhole Desilting/ Grabbing app																				
d)	Sewer Inspection Cametas Appar																				
e)	Sewer Bucket Apparatus (Nallah																				
f)	Rodding Machines																				
g)	Jetting Machines																				
h)	Sewer Croc Apparatus																				

//True copy//

			i) Safety Gear Set (as per CPHEEO Norms)
VI.	The feasibility of developing interest based solution for real time tracking of sewage death and action taken by their concerned authorities including the appropriate Government towards payment of compensation and rehabilitation of families.		In so far as Meghalaya is concerned there is no sewerage system in the State, therefore action on matters relating to it does not arise.

//True copy

J753166/2024

Government of Punjab
Department of Social Justice, Empowerment & Minorities
(Special Welfare Cell-1)

To

Secretary to Government of India,
Ministry of Social Justice & Empowerment,
Shastri Bhawan, New Delhi-110001

Dated: Chandigarh 03.01.2024

Subject: Information in Writ Petition (Civil) No. 324/2020 filed by Dr. Balram Singh Vs Union of India & Ors. reg- Prohibition of Employment as Manual Scavengers and their Rehabilitation Act, 2013.

Sir,

Please refer your letter No. U-12021/1/2023-PLAN dated 14.11.2023 and U-12012/1/2023 (Plan) dated 15.12.2023 on the subject cited above.

2. The Action Taken Report on the subject matter is being sent herewith for information and necessary action please.

Yours faithfully,

Under Secretary
A

Enclosures:- As above

//True copy//

//Kiran Singh

108 ..

1753165/2024

03/01/2024

-2-

A copy of the above is forwarded to Principal Secretary, Government of Punjab, Local Government alongwith action taken report for information.

Enclosures:- As above

Daljit Singh
Under Secretary
A

A copy of the above is forwarded to Director, Social Justice, Empowerment & Minorities, Punjab alongwith action taken report for information.

Enclosures:- As above

Daljit Singh
Under Secretary
A

A copy of the above is forwarded to OSD (L)/Chief Secretary, Government of Punjab, alongwith action taken report for information.

Enclosures:- As above

Daljit Singh
Under Secretary
A

ਕਿਰਪਾ ਕਰਕੇ
ਦਿਖਾਓ

//True copy//

753165/2024

03/01/2024

-3-

Sar No.	Directions of Hon'ble Supreme Court order dated	Action Taken Report
	20.10.2023	received from concerned department
1.	MS Act, 2013; MS Rules 2013 and guidelines framed by the Union are embodied in States/UTs guidelines and directions are applicable to all municipalities and local bodies [para 96 (2)].	Necessary Directions have already been Issued to all the ULBs vide Local Government letter No. 1927 dated 29.12.2023 for compliance of Act in letter & spirit.
2.	Full rehabilitation (including employment to the next of kin, education to wards, and skill training) to sewage workers, and those who die [para 96 (3)].	Rehabilitation by way of employment has been done for the eligible families and the benefits of Scholarships to the Children of those engaged in unclean occupation have already been covered under (100% Centrally Sponsored Scheme) and Post Matric Scholarship for Schedule Caste students and others.
3.	Payment of compensation with increased amount i.e., Rs. 30 lakhs for sewer deaths. In the event dependents of any victim have not been paid such amount, the above amount shall be payable to them, hereafter as compensation [para 96 (4)].	Out of 41 cases payment of compensation have been paid to 39 families, rest in 2 cases, in one case, compensation has been partially paid & same is pending before Hon'ble High Court due to family dispute. in Second case, family of deceased is not traceable, as

//True copy//

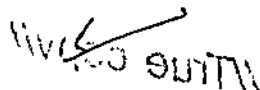

110

1753165/2024

03/01/2024

		& when it will be traced or contacted compensation will be paid accordingly.
4.	Payment of compensation of Rs. 20 lakhs, in the case of sewer victims suffering disabilities, depending upon the severity of disabilities. Minimum compensation shall not be less than Rs. 10 lakhs [para 96 (5)].	No case is reported.
5.	Devise suitable mechanism to ensure accountability, especially wherever sewer deaths occur in the course of contractual or "outsourced" work [para 96 (6)].	Standard Operating Procedure (SOP) for cleaning of sewers, manholes and septic tanks has already been circulated to all the departments for strict compliance vide Local Government letter number 1927 dated 29.12.2023.
6.	Set up scholarships to ensure that the dependents of sewer victims, (who have died, or might have suffered disabilities) are given meaningful education [para 96 (10)].	The benefits of Scholarships to the Children of those engaged in unclean occupation have already been covered under (100% Centrally Sponsored Scheme) and Post Matric Scholarship for Schedule Caste students and others.
7.	Ensure establishment of State Commission for Safai Karmacharis and all Committees mentioned in MS Act, 2013 and MS Rules 2013 including State Monitoring Committee, State Level Survey Committee, District Vigilance Committee and District	State Safai Karmacharis Commission, State Monitoring Committee, State Level Survey Committee & District

//True copy//

753165/2024

03/01/2024

	Level Survey Committee by 30.11.2023 [para 96 (12)].	Vigilance Committee have already been constituted. - Instructions have been issued to all DMs for constitution of District Level Survey Committee.
--	------------------------------------------------------	-----------------------------------------------------------------------------------------------------------------------------------------------------------

//True copy//

livera 

DIRECTORATE OF LOCAL GOVERNMENT, PUNJAB, CHANDIGARH
(Punjab State Urban Livelihood Mission)
Municipal Bhavan, Plot No.-3, Room No. 405 4th Floor,
Sector 35A, Chandigarh

No: - PSULM/2023/1927

Ph. no - 0172-2660053,84.

Dated:- 29/12/2023

emali:- td.suda@punjab.gov.in

To

1. All Commissioners, Municipal Corporations in the State of Punjab.
2. All Additional Deputy Commissioners (UD/General), in the State of Punjab.

Subject:- Regarding Standard Operating Procedure (SOP) for cleaning of sewers, manholes and septic tanks.

It is informed that vide letter no PWSSB/2023/QC/29864 dated 27.12.2023 received from Punjab Water Supply and Sewerage Board w.r.t. "Standard Operating Procedure" for cleaning of sewers, manholes and septic tanks is enclosed herewith.

You are requested to inform all the ULBs under your control to take further necessary action and ensure the compliance of the directions.

Joint Director

**PUNJAB WATER SUPPLY & SEWERAGE BOARD
PLOT NO.1-B, SECTOR 27-A, CHANDIGARH**

From

Engineer-in-Chief cum
Technical Advisor

To

The Director
Department of Local Government
Sector-35, Chandigarh

*SOLN to
circulate
to all concerned.*

No. PWSSB/2023/QC/ 29864

Dated 27/12/2023

Subject-

Standard Operating Procedure (SOP) for Cleaning of Sewers,
Manholes and Septic Tanks

*CC
CE(AM)/TD
ATL*

As discussed in the meeting held with your good office dated 21.12.2023, PWSSB was directed to prepare Standard Operating Procedure (SOP) for cleaning of sewers, manhole and septic tanks.

In this regard, it is submitted that Ministry of Housing and Urban Affairs, Govt. of India has already released Standard Operating Procedure (SOP) for cleaning of sewers and septic tanks (Copy Enclosed). The SOP describes set of procedures to be followed for cleaning of sewers and emptying of septic tanks including the precautions to be employed and the emergency preparedness.

GM (Project), PMDC on the orders of Worthy Secretary, Local Govt. has circulated the SOP in the offices of Engineer-in-Chief (PWSSB), The Regional Deputy Director (Local Govt - Amritsar, Jalandhar, Ludhiana, Patiala, Bathinda, Ferozepur) and The Commissioner (Municipal Corporation - Amritsar, Jalandhar, Ludhiana, Patiala, Bathinda, Moga, Hoshiarpur, Pathankot, SAS Nagar, Phagwara), vide their office memo no. PMDC/GM(P)/2019/350-352 dated 15.01.2019. Further, The SOP was circulated in the field offices of PWSSB vide this office letter no. 1619, 643 dated 23.01.2019.

This is for your kind information and further necessary action please.

DA/Copy of SOP for cleaning
of sewers and septic tanks

~~27/12/23~~
Engineer-in-Chief-cum
Technical Advisor

16.12.2023
27/12/23

//True copy//

Standard Operating Procedure (SOP) for Cleaning of Sewers and Septic Tanks



Central Public Health and Environmental Engineering Organization (CPHEEO)

Ministry of Housing and Urban Affairs
Government of India

www.amrut.gov.in

November 2018

// For copy //

Standard Operating Procedure (SOP)
for
Cleaning of Sewers and Septic Tanks

Central Public Health and Environmental Engineering Organization (CPHEEO)

Ministry of Housing and Urban Affairs
Government of India

www.amrut.gov.in

November 2018

//True copy//

Message

हरदीप एस पुरी
HARDEEP S PURI



हरदीप पुरी

आवासन और शहरी कार्य
राज्य मंत्री (स्वतंत्र प्रभार)
भारत सरकार
MINISTER OF STATE (I/C)
HOUSING AND URBAN AFFAIRS
GOVERNMENT OF INDIA



Message

For the past many years, Ministry of Housing and Urban Affairs has taken various steps to facilitate States/ UTs to eliminate manual scavenging by providing central assistance to them for switching over to mechanized cleaning of sewers and emptying of septic tanks.

This Standard Operating Procedure (SOP) contains procedures to be followed during mechanical and manual cleaning of sewers and emptying of septic tanks. Efforts have been made to make this SOP easily adoptable by the Urban Local Bodies (ULBs). The SOP will be useful not only for the ULBs across the Country, but also for the individual, contractors, cleaning workers and private stakeholders.

I take this opportunity to congratulate the concerned officers in the Ministry for bringing out this user-friendly SOP.

New Delhi
16 November 2018

(Hardeep S Puri)

1/11/18 copy

Foreword

दुर्गा शंकर मिश्रा
सचिव
Durga Shanker Mishra
Secretary



भारत सरकार
आवासन और शहरी कार्य मंत्रालय
निर्माण भवन, नई दिल्ली-110011
Government of India
Ministry of Housing and Urban Affairs
Nirman Bhawan, New Delhi-110011

FOREWORD

As per the 2011 Census, 81.4% households had toilet facilities within their premises. Out of this, 32.7% households had water closets connected to sewer system and 38.2% households were having water closets with septic tank. This percentage of households having water closets with septic tank have increased drastically in the last four years due to conversion of insanitary latrines into sanitary latrines and construction of sanitary toilets for individual and public under Swachh Bharat Mission - Urban (SBM-U).

Further, a huge amount of sewerage infrastructure is being developed under Atal Mission for Rejuvenation and Urban Transformation (AMRUT) in the past three years. This SOP together with the Manual on Sewerage and Sewage Treatment Systems, 2013, wherein, the different methods of mechanized & manual cleaning of sewers & septic tanks are discussed, will provide requisite guidance for officials to switch over to mechanized cleaning and eliminate human costalities.

3. I believe that this SOP will go a long way in improving the working condition of all those involved in operation and maintenance of sewers and emptying of septic tanks. I hope Municipalities / Municipal Corporations will make extensive use of this SOP to mitigate the current miseries. I welcome suggestions from stakeholders and experts to further improve it on email: vk.chaturvedi@nic.in

(DURGA SHANKER MISHRA)

New Delhi
November 15, 2018

Office Address: Room No. 122 C Wing, Nirman Bhawan, New Delhi-110011
Tel: 011-23062377, 23061179, Fax: 011-23061450 Email: secyurban@nic.in
Website: www.mha.gov.in

//True copy//

Contents

1	INTRODUCTION	1
2	SCOPE	1
3	OBJECTIVE	1
4	INITIATIVES TAKEN BY GOVERNMENT OF INDIA	1
5	CLEANING OF SEWERS	3
5.1	Cleaning Frequency	3
5.2	Procedures for Cleaning of Sewers	3
5.2.1	Mechanical	3
5.2.2	Manual	4
6	EMPTYING OF SEPTIC TANKS	5
6.1	Emptying Frequency	5
6.2	Procedures followed for Emptying of Septic Tanks	5
7	EMERGENCY PREPAREDNESS	6
8	GAS EMERGENCY	7
9	PRECAUTIONS	7
9.1	Precautions against Gas Hazards	7
9.2	Precautions against Infection	8
9.3	Precautions to be taken while working near Vehicular Traffic	8
10	PROTECTIVE GEARS AND SAFETY DEVICES	8
11	GUIDANCE FOR SELECTION OF SEWER/ SEPTIC TANK CLEANING EMPLOYEES	8
11.1	Requirements for Duties Not Requiring Entry into Confined Space	8
11.2	Requirements for Duties Requiring Entry into Confined Space	8
12	TYPE OF INSPECTIONS AND EXAMINATIONS OF SEWERS	9
12.1	Direct Method	9
12.2	Indirect Method	10
12.2.1	Light and Mirror Method	10
12.2.2	Closed Conduit Camera Method	10
12.2.3	Sonar System	10

13	METHODS OF CLEANING SEWERS AND SEPTIC TANKS	10
13.1	Manual Methods	11
13.1.1	Manila Rope and Cloth Ball	11
13.1.2	Sectional Sewer Rods	11
13.1.3	Scraper	11
13.2	Mechanical Methods	11
13.2.1	Sewer Cleaning Bucket Machine	11
13.2.2	Rotating Machine with Flexible Sewer Rods	11
13.2.3	Hydraulically Propelled Devices	12
13.2.4	Velocity Cleaners (Jetting Machines)	12
13.2.5	Dredger (Clam-shell) - for manhole cleaning	12
13.2.6	Gully Emptier (Suction Units)	12
14	ROLES & RESPONSIBILITIES	12
14.1	Urban Local Bodies (ULBs)	12
14.2	Registered Agencies/Contractors/Employers	13
14.3	Employees	13
14.4	Individuals	14
	TERMINOLOGY	15
	Annexure - I	17
	Annexure - II	18
	Annexure - III	19

//True copy//

1 INTRODUCTION

As per the 2011 census, the share of urban population is 31.2% against 18% of 2001 census of the total population of the country which is expected to be 50% by 2050. This increase in population has created a significantly enhanced demand on urban sanitation, inter alia. As per the 2011 Census, 81.4% households have toilet facilities within their premises. Out of this, 31.7% households have water closets connected to sewer system and 38.2% households are having water closets with septic tank. Remaining 18.6% households do not have toilet facilities within their premises. However, at present under Swachh Bharat Mission (Urban), the toilet facilities have significantly improved at present all the cities and towns are expected to be open defecation free before end October 2019.

Government of India had notified Prohibition of Employment as Manual Scavengers and their Rehabilitation Act, 2013 and Rules 2013. As per the Rules, for the purposes for removal of submersible pump set fixed at the bottom of the suction wells at sewage pumping stations, reconstruction of manhole, rectification of the sewer main, before allowing entry of a person in the sewer, sewage shall be totally emptied.

Working near or in a manhole inherits potential dangers which may result in serious accidents and in some extreme cases, loss of life as well. The common accidents include falls/slips, fire or explosion, oxygen depletion, gas poisoning, heat stress, drowning, asphyxiation arising from gas, fumes, vapour and entrapment by free-flowing solids. Amongst these, dangerous gases are easily overlooked or neglected, leading to serious casualties.

The health and safety of personnel can be safeguarded to a great extent by use of safety equipment and by taking precautions appropriate for each hazard condition. In order to cater the issues of hazardous cleaning, this Standard Operating Procedure (SOP) discusses on the precautionary steps to be followed while cleaning of sewers and desludging of septic tanks. Further, the document also enlightens ideas on various mechanized sewer & septic tank cleaning

procedure and technologies to eradicate hazardous cleaning. This SOP may also be read in conjunction with Act and Rules, in case of any clarification.

2 SCOPE

The scope of the SOP is to impart the knowledge into the stakeholders about the cleaning of sewers and emptying of septic tanks before and after the assignment. This document would be found useful by all Urban Local Bodies (ULBs), Public Health Engineering Departments and other agencies engaged in the process of cleaning of sewers / emptying of septic tanks across the country. Further, the procedures mentioned in SOP shall also be applicable to the contractors who employ person(s) for cleaning of sewers/ emptying of septic tanks and the individuals who hire such person(s) for cleaning their sewers/ emptying of septic tanks in their premises. States/UTs shall publish this SOP in local language for better understanding of the concerned agencies and individual, as per the necessity.

3 OBJECTIVE

The main objective of this SOP is to eliminate hazardous cleaning or at least to avoid the accidents due to improper practice of cleaning of sewers/ emptying of septic tanks, thereby, preventing human casualties. Further, the SOP intends to prevent the risk of acquiring diseases to the concerned person because of following the unhygienic & unscientific working procedures. This SOP also provides information on protective gears, their applicability to sewers/septic tanks cleaning, emergency preparedness, emergency due to toxic gas emission, precaution to gas hazard & infection, precaution due to vehicular traffic, responding to sewers/ septic tanks overflows by field workers/ employees in case of crisis, responsibility to stakeholders and so on.

4 INITIATIVES TAKEN BY GOVERNMENT OF INDIA

- (i) Prohibition of Employment as Manual Scavengers and their Rehabilitation Act, 2013
The "Prohibition of Employment as Manual Scavengers and their Rehabilitation Act, 2013" described "hazardous cleaning" by an employee, in

relation to a sewer or septic tank, means its manual cleaning by such employee without the employer fulfilling his obligations to provide protective gear and other cleaning devices and ensuring observance of safety precautions, as may be prescribed or provided in any other law for the time being in force or rules made thereunder.

Further, the Act defined that a person engaged or employed to clean excreta with the help of such devices and using such protective gear, as the Central Government may notify in this behalf, shall not be deemed to be a 'manual scavenger'. It is the duty of every local authority and other agency to use appropriate technological appliances for cleaning of sewers, septic tanks and other spaces within their control with a view to eliminate the need for the hazardous cleaning.

Main features of the Act are

- a) Definitions of manual scavengers and insanitary latrines widened to cover not only dry latrines but other insanitary latrines as well.
- b) Offences under the Act are cognizable and non-bailable and attract stringent penalties.
- c) Vigilance/Monitoring Committee at sub-Division, District, State and Central Govt. levels.
- d) National Commission for Safai Karamcharis (NCSK) would, inter alia, monitor implementation of the Act and enquire into complaints regarding contravention of the provisions of the Act.
- e) Provision of construction of adequate number of sanitary community latrines in urban areas, within three years from the date of commencement of this Act to eliminate the practice of open defecation.

(ii) Prohibition of Employment as Manual Scavengers and their Rehabilitation Rules, 2013

Prohibition of Employment as Manual Scavengers and their Rehabilitation Rules, 2013 has been notified by Ministry of Social Justice and Empowerment under the provisions of Prohibition of Employment as Manual Scavengers and their Rehabilitation Act, 2013. As per the Rules, no person shall be allowed to clean a sewer manually, with the protective gear and

safety devices except

- a) for the removal of concrete or FRP (Fibre Reinforced Plastic) or damaged manhole cover where mechanical equipment's cannot be put into operation;
- b) for inter-linking the newly laid sewer main with the existing sewer main, in case of sewer of size more than 300 mm diameter.
- c) for removal of submersible pump sets fixed at the bottom of the suction wells of sewage pumping stations / STP
- d) for the reconstruction of the manhole or rectification of the sewer main.
- e) Any circumstance, when it is absolutely necessary to have manual sewage cleaning, after Chief Executive Officer (CEO) or Head of the Local Authority has permitted to do so after recording in writing the specific valid reasons for allowing such cleaning.

The Rules requires to monitor and oversee the survey of manual scavengers at District and State level. District Level Survey Committee. It mandates a State Level Survey Committee should be constituted, and to publish final consolidated list of manual scavengers in the State.

(iii) Swachh Bharat Mission - Urban (SBM-U)
Swachh Bharat Mission - Urban (SBM-U) is under implementation in all urban areas with the objective to make urban areas open defecation free by converting the insanitary latrines into sanitary latrines and providing individual household latrines, community and public latrines with urinals. The Mission also includes awareness creation among the various stakeholders through Information, Education & Communication (IEC) & Public Awareness activities.

(iv) Atal Mission for Rejuvenation and Urban Transformation (AMRUT)

The Atal Mission for Rejuvenation and Urban Transformation (AMRUT) a Centrally Sponsored Scheme is under implementation with the development of basic urban infrastructure including sewerage and septage management in 500 cities/towns in the country. Government of India is

//True copy//

providing financial assistance to all States/UTs for creation of infrastructure and mechanized cleaning of sewers and septic tanks.

(v) **Manual on Sewerage and Sewage Treatment Systems, 2013**

Ministry of Housing and Urban Affairs has published 'Manual on Sewerage and Sewage Treatment Systems, 2013', wherein the different methods for mechanized & manual cleaning of sewers & desludging the septic tank without human interventions are discussed and may be referred to.

(vi) **IS 11772 - 2002: Code of Practice For Safety Precautions To Be Taken When Entering A Sewerage System**

This standard lays down guidelines for selection of sewermer and safety measures against gas hazard, infection with a view to provide some basic guidance for selection of employees for sewer cleaning and proper instructions for safe working in a sewerage system.

5 CLEANING OF SEWERS

Mechanical cleaning of sewers is the most preferred method and shall be employed to the extent possible. Manual entry for hazardous cleaning of sewers is completely banned as per the Prohibition of Employment as Manual Scavengers and their Rehabilitation Rules, 2013 & Rules, 2013. To operate and maintain a sewer collection system to function as intended, the maintenance engineer should try to strive towards the objectives to minimize the number of blockages per unit length of sewer, and to minimize the number of odour complaints. For this purpose, sewer-cleaning using hydraulic or mechanical cleaning methods needs to be done on a scheduled basis to remove accumulated debris in the pipe such as sand, silt, grease, roots and rocks.

5.1 Cleaning Frequency

The frequency of cleaning of sewers is based on the prevailing local conditions and determined through field inspections & complaints received from the residents of the area. However, it is desirable to clean the sewer at least once in every 6 months (ideally once just before monsoon season). Inspections and

examinations of the sewers and septic tanks shall be made before to start the cleaning which is explained in SOP.

5.2 Procedures for Cleaning of Sewers

5.2.1 Mechanical

Step 1: Reaching the site

- i. Selection of prospective employees for the sewer cleaning should take into account the duties they will be expected to perform;
- ii. The complete hazard involved in the cleaning activity should be explained clearly to the employees by the supervisor and should get their consent in written before starting cleaning activities;
- iii. A supervisor along with adequate machinery and staff shall reach the designated site, preferably during lean period of sewage flow in sewers;
- iv. The supervisor shall have the names, address and emergency contact information of the staff involved in cleaning the sewers and
- v. Appropriate protective gears and safety devices shall be worn by the staff before beginning the work of cleaning the sewers.

Step 2: Identification and isolation of the area

- i. Identify the stretch to be cleaned and identify the manholes associated with the stretch;
- ii. Barricade the area where cleaning is to be carried out; and
- iii. A flag man shall be stationed at least 15 m ahead of the site and should be visible to incoming traffic for at least 150 m;
- iv. Cones (similar to the one used by police) shall be placed on the road.

Step 3: Verify the presence of any gases or other hindrances

- i. Ventilate the sewer line by opening 2-3 manholes on both sides of the working stretch for at least 1 hour prior to start of the work to ensure escape of toxic gases; The worker opening the manhole must not bend down into the opened manhole and this may cause his getting overcome by Hydrogen Sulphide and even tripping into the manhole.

ii. Use gas monitor, detector lamp, wet acetate paper or gas detector masks to detect any residues of poisonous gases like hydrogen sulphide, carbon monoxide, methane and gasoline vapours.

iii. Insert a long pole with lead acetate paper which will convert to black colour in the presence of hydrogen sulfide. The person shall not try to insert the paper by hand into the manhole.

iv. If gases are detected, extend waiting period to allow residual gases to escape and to avoid the chance of explosion, in case. Repeat the procedure many times for checking the escape of toxic gases.

v. Before the start of the cleaning operation, employees shall check for hindrances that may delay the cleaning process; and

vi. Dummy covers with welded fabric or wire net shall be used to cover the manhole, if required. However, care should be taken to ensure that the cover is strong enough to hold a man's weight.

Step 4: Removal of silt/wax - Mechanical Process

i. Appropriate machines, as least to the extent specified in this SOP are to be used to remove the silt/wax.

ii. The operating procedures of these machines shall be strictly followed for cleaning; and

iii. The manhole cover shall be closed tightly after cleaning.

Step 5: Leaving from the site

i. All the equipment/machineries along with the protective gears and safety devices that had any direct contact with the sewage shall be cleaned properly as per the cleaning procedure specified by the manufacturer;

ii. All the equipment, safety gears, barricades etc shall be removed from the working area and the crew shall move to the base or to the next site; and

iii. The entire operation shall be monitored and documented by the supervisor.

5.2.2. Manual

Step 1: Reaching the site

i. Selection of prospective employees for sewer cleaning should take into account the duties they will be expected to perform.

ii. The complete hazard involved in the cleaning activity should be explained clearly to the employees by the supervisor and should get their consent in written before to start cleaning activities;

iii. A supervisor along with adequate machinery and staff shall reach the designated site, preferably during lean period of sewage flow in sewer;

iv. The supervisor shall have the names, address and emergency contact information of the staff involved in cleaning the sewers; and

v. Appropriate protective gears and safety devices shall be worn by the staff before the start of work on cleaning the sewers.

Step 2: Identification and Isolation of the area

i. Identify the stretch to be cleaned and identify the manholes associated with the stretch.

ii. Barricade the area where cleaning is to be carried out; and

iii. A flag man shall be stationed at least 15 m ahead of the site and should be visible to incoming traffic for at least 150 m.

iv. Cones (similar to the one used by police) shall be placed on the road.

Step 3: Verify the presence of any gases or other hindrances

i. Ventilate the sewer line by opening 1-3 manholes on both sides of the working stretch for at least 1 hour before to start the work to ensure escape of toxic gases;

ii. The labour opening the manhole must not bend down into the opened manhole and this may cause his getting overcome by Hydrogen Sulphide and even tripping into the manhole.

iii. Use gas monitor, detector lamp, wet acetate paper or gas detector masks to detect any residues of poisonous gases like hydrogen sulphide, carbon monoxide, methane and gasoline vapours;

iv. Insert a long pole with lead acetate paper which will convert to black. The person shall not try to insert the paper by hand into the manhole.

v. If gases are detected, extend waiting period to allow residual gases to escape and to avoid the chance of casualty, in case. Repeat the procedure many times for checking the escape of toxic gases.

//True copy

- vi. Before to start the cleaning operation, employees shall check for hindrances that may delay the cleaning process; and
- vii. Dummy covers with welded fabric or wire net shall be used to cover the manhole, if required.

Step 4: Removal of silt/clogs/rocks

- i. Identify and close off or re-route the inlet sewage of the remedial stretch, if possible;
- ii. Check the oxygen level in the manhole. If it is less than 19.5%, greater than 21% at any of the three levels (bottom, middle and top), the staff (as it may be) shall not be allowed to enter the manhole;
- iii. Air should be supplied into the manholes or to make provision of ventilation to achieve the desired oxygen level;
- iv. The staff shall wear full body suit if entering manhole of more than 5 ft. depth or partial fishing wade suits if entering manholes of less than 5 ft. depth;
- v. All the staffs entering the sewer shall wear helmet attached with head lamp;
- vi. The staff entering the sewer shall preferably wear full-face mask having escape breathing apparatus with air supply along with other appropriate protective gears and safety devices;
- vii. Safety belt shall be fastened tightly onto their suit;
- viii. The staff shall have extra flashlights and communication devices such as two-way radios;
- ix. The staff shall check for the stability of the manhole walls visually and the strength of the rope ladder and descend into the manhole carefully after getting the permission of the supervisor;
- x. The persons entering the manhole shall be monitored by CCTV cameras or any other suitable mechanism at the ground;
- xi. Obstructions shall be removed by using appropriate machinery/equipment and brought up to ground level and then shall be suitably disposed at the designated area;
- xii. Pull the ladder out of the manhole after completion of cleaning activities;
- xiii. Manhole lid shall be closed tightly after cleaning; and



- xiv. At a stretch duration not exceeding 90 minutes shall be taken. Cleaning the sewer and mandatory interval of 30 minute shall be given to the staff involved in cleaning between two intervals.

Step 5: Leaving from the site

- i. All the equipment/machineries along with the protective gears and safety devices that had any direct contact with the sewage shall be cleaned properly as per the cleaning procedure specified by the manufacturer;
- ii. All the equipment, safety gears, barricades etc shall be removed from the working area and the crew shall move to the base or to the next site; and
- iii. The entire operation shall be monitored and documented by the supervisor.

6 EMPTYING OF SEPTIC TANKS

6.1 Emptying Frequency

Regular emptying of septic tanks through a systematic extraction and collection procedure is essential to check environmental pollution. The frequency of emptying is determined by the local conditions including loading rate and performance of septic tanks. However, it is ideal to clean the septic tanks once in one year or two years based on its design criteria. But in no case the cleaning frequency shall exceed two years.

6.2 Procedures followed for Emptying of Septic Tanks

- (i) Inform the occupant of the pending service and note any concerns or issues;

//True copy//
08/11/11



- (ii) Inspect the site for possible hazards, such as clearing the area of people, or identifying high groundwater that could cause a tank to 'float', if emptied;
- (iii) Park the truck as close to the septic tank as possible. The maximum distance is determined by the length of hose and elevation rise from the bottom of the pit or septic tank to the vacuum truck. This should typically be not more than 25 meters in linear distance and 4 meters in elevation gain. In case, the length and elevation is more than the specified, immediate pumping may be required;
- (iv) Break the mortar seal of the septic tank lid. Inspect the tank for cracks or damage before and after the emptying of tank;
- (v) Lay out and connect the hoses from the truck to the tank or pit to be emptied and secure the truck using wheel chocks;
- (vi) It is essential to ensure that the hose is in sound condition, and that the hose connections are locked into place prior to using this method;
- (vii) Follow the safety instruction as prescribed in above section of mechanical cleaning of sewers;
- (viii) Open the tank or pit by removing the access port or covers over the storage system;
- (ix) Engage the vacuum equipment by using a power take-off from the truck's transmission;
- (x) Increase the vacuum to the proper level with the valve closed by watching the vacuum gauge, then lowering the end of the hose into the septic tank, and open the valve sufficiently such that the faecal sludge is drawn out of the tank or pit;
- (xi) Break up faecal sludge that has agglomerated into a solid mass, either by making use of a long handle shovel and adding water when necessary;
- (xii) Operators shall leave behind sludge not less than 25 mm in depth in the bottom of the septic tank as this will act as the seeding material;
- (xiii) Identify any abnormal conditions, such as high concentration of non-biodegradable materials, oils and grease before taking to the treatment plant for final disposal;
- (xiv) If the cover of the tank has been removed, it should be replaced and sealed with cement plaster. If desludging has been carried out through a desludging hatch, the cover of the hatch should be replaced and sealed with cement plaster;
- (xv) Clean up any spillage using proper sorbent materials. The top of the cover and the area around the septic tank is sprayed with 1% chlorine solution;
- (xvi) Two sets of working clothes will be provided for each worker, which should be dedicated to be used only during the desludging process. Clothes worn during the desludging process should be removed before the workers return home;
- (xvii) Prepare a written report indicating: how much waste was removed; the condition of the tank or pit; any recommendations for repairs or maintenance; any recommendations for proper use of the system;
- (xviii) Inform the client that the work is complete, and give them the final report along with recommendations, if any;
- (xix) The final report shall also be entered in the computer in the ULB so as to provide a database and to also know about the next emptying date, etc;
- (xx) Remove the wheel chocks and drive the truck to the next site or to the nearest approved disposal site.

7 EMERGENCY PREPAREDNESS

- i. Emergency plan to execute the work shall be prepared before arriving at the site;
- ii. The supervisor and all the crew members involved in sewer cleaning should be familiarized with the emergency plan;
- iii. A tripod attached with rope & pulley and harness or some other suitable system shall be put in place for retrieving the injured worker;
- iv. A first aid kit distinctly marked with a red cross on white back ground shall be readily available at the site which should at least have the items listed in Annexure-L;
- v. Wash-up material like soap & skin cream for applying on the body shall be adequately available at the site.

//True copy//

- v. A list of medical care centers available near the site may be prepared and made readily available;
- vi. Vehicle preferably an ambulance shall be available at the site for carrying the injured worker(s) to the hospital, in case of any emergency.

8 GAS EMERGENCY

- i. If a gas emergency occurs everyone should immediately put on their escape sets (breathing apparatus) and raise the alarm.
- ii. The men at the ground level are trained rescuers and they shall immediately send down the rescue sets and await the men working in sewer to come out. The men at the ground level shall attempt to rescue the man inside sewer with all the equipment at their disposal.
- iii. If there is a casualty, he should be propped up out of sewage in a comfortable position. Immediately call the emergency services (ambulance, fire brigade). When the victim has the gas mask on the face and if he is breathing, a rescuer should always be with him because he may vomit thereby choking the supply of oxygen.
- iv. Guidelines for giving first-aid to a gas victim are given below:
 - a. Remove him to fresh air as soon as possible.
 - b. Apply artificial respiration with an oxygen resuscitator if he is not breathing. If one is not available, apply mouth to mouth breathing; and
 - c. Keep him lying down and wait for an ambulance.

9 PRECAUTIONS

9.1 Precautions against Gas Hazards

When a sewer or a manhole is required to be entered for cleaning or clearing an obstruction, where dangerous gas or oxygen deficiencies may be present, the following precautions shall be taken:

- i. The following shall not be allowed, (a) smoking, (b) open flames and (c) spark.
- ii. Erect warning signs.
- iii. Use fully safety gas-proof electric lighting equipment or mirror for reflection of light.
- iv. Test the atmosphere for noxious gases and oxygen deficiencies. In case of scum formation the sewage and sediments in the manhole should be agitated with the help of rod or any other suitable instrument for trapped gases and the manhole should be checked for noxious gases and oxygen deficiencies.
- v. If the atmosphere is normal, workmen may enter with a safety belt attached and with at least two men available at the ground level. For extended jobs, the gas tests shall be repeated every three minutes while men are in the sewer.
- vi. If oxygen deficiency or noxious gas is found, the structure shall be ventilated with pure air by keeping open at least one manhole cover each on upstream and downstream side for quick exit of toxic gases or by forced ventilation using a portable blower. The gas tests shall be repeated before entering. Adequate ventilation shall be maintained during the work and the gas test shall be repeated every three minutes.
- vii. If the gas or oxygen deficiency is present and it is not practicable to ventilate adequately before workers enter, hose masks shall be worn and extreme care shall be taken to avoid all sources of ignition. Workers shall be taught how to use the hose equipment. In these cases, they shall always use permissible safety lights (not ordinary flash lights) rubber boots or non-sparking shoes and non-sparking tools.
- viii. Workmen descending a manhole shaft to inspect or clean sewers shall try each ladder step or rung carefully before putting the full weight on it to guard against insecure fastening due to corrosion of the rung at the manhole wall. When work is going on in deep sewers, at least two men shall be available for lifting workers from the manhole in the event of serious injury, and
- ix. Portable air blowers, for ventilating manhole, are recommended for all tank, pit or manhole work where there is a possibility of presence of noxious gas, vapours or oxygen deficiency. The motor of these air blowers shall be of weatherproof and flameproof type, compression-ignition-diesel type (without sparking plug). These shall be placed not less than 2m away from the opening and on the leeward side protected from wind so that they will not serve as a source of ignition for any inflammable gas which may be present. Forced type ventilation should be provided by blower located at ground level with suitable flexible ducting to displace the air from the manhole.

9.2 Precautions against Infection

The personnel working in sewerage maintenance systems are prone to infections and hence the following precautions should be taken:

- i. The workers should be educated about the hazards of waterborne diseases such as typhoid and cholera through sewage and tetanus through cuts and wounds. Cuts and grazes should be covered with waterproof plasters. Effective immunization of workers against diseases such as typhoid, cholera, tetanus, etc. should be done by vaccination.
- ii. The importance of personal hygiene should be emphasized and the worker should be instructed to keep fingernails short and well-trimmed, wash hands with soap and hot water before taking food and to keep fingers out of nose, mouth and eyes, because the hands carry most infection.
- iii. Use of rubber gloves shall be insisted, so that sewage or sludge does not come in direct contact with hand. Before starting work, skin likely to be exposed to sewage should be covered with barrier cream.
- iv. The worker should be provided with a complete change of work clothes to be worn during working hours. Gum boots should also be provided for the workers.
- v. When the work is completed, thoroughly wash all contaminated parts of the body.

9.3 Precautions to be taken while working near Vehicular Traffic

- i. Workers (on foot) exposed to vehicular traffic must wear fluorescent flagging garments.
- ii. Workers shall not wear any type of headgear that can interfere with hearing back up alarms, warnings, etc.
- iii. When hazards to workers exist because of vehicular traffic, use traffic controls in conformance with the Local Transport Authority.
- iv. Additionally, controls such as detours, warning signs, or barricades shall be used when necessary. Flares are required where these controls are ineffective.
- v. Whenever mobile equipment operation encroaches upon a public thoroughfare, a system of traffic controls must be used.

10 PROTECTIVE GEARS AND SAFETY DEVICES

All the protective gears and safety devices shall be checked once in every six months and repaired/replaced as necessary. Proper inventory of all the protective and safety gears to be maintained. The following (refer table 1) are the protective gears and safety devices, but not limited to, as prescribed by Prohibition of Employment as Manual Scavengers and their Rehabilitation Rules, 2013 to prevent any hazardous entry of humans into the sewers.

11 GUIDANCE FOR SELECTION OF SEWER/SEPTIC TANK CLEANING EMPLOYEES

11.1 Requirements for Duties Not Requiring Entry into Confined Space

No specific requirements except a routine medical examination shall be made. Those with the following disabilities shall not be selected as any of the disease involves risks to the health and safety of both the prospective employee and/or other employees:

- a) History of fits, blackouts, fainting attacks;
- b) Chronic skin disease; and
- c) Meniere's disease or diseases involving loss of balance.

11.2 Requirements for Duties Requiring Entry into Confined Space

Persons considered for employment in confined spaces shall be physically fit and capable of understanding training given. Those with the undernoted disabilities shall not be recruited for this type of work and those who contract these should cease to be employed in this capacity:

- a) A history of fits, blackouts or fainting attacks;
- b) A history of heart disease or disorder;
- c) High blood pressure;
- d) Asthma, bronchitis or a shortness of breath on exertion;
- e) Deafness;
- f) Meniere's disease or disease involving giddiness or loss of balance;
- g) Claustrophobia or nervous or mental disorder;
- h) Back pain or joint trouble that would limit mobility in confined spaces.

Table 1

Protective gear and safety devices		Protective gear and safety devices	
1. Air compressor hot blower	2. Ablative breathing apparatus	1. Air compressor hot blower	2. Ablative breathing apparatus
3. Airline respirator with manually operated air blower	4. Air purifier gas mask/char cartridge	3. Airline respirator with manually operated air blower	4. Air purifier gas mask/char cartridge
5. Artificial respiration/reticulate	5. Barrier caution tape	5. Artificial respiration/reticulate	5. Barrier caution tape
7. Barrier cream	8. Barrier cone	7. Barrier cream	8. Barrier cone
9. Blower	10. Breath mask	9. Blower	10. Breath mask
11. Breathing apparatus	12. Caution board	11. Breathing apparatus	12. Caution board
15. Chlorine mask	14. Emergency medical oxygen respirator kit	15. Chlorine mask	14. Emergency medical oxygen respirator kit
15. First aid box	15. Face mask	15. First aid box	15. Face mask
17. Gas monitor (4 gases)	18. Guide pipe set	17. Gas monitor (4 gases)	18. Guide pipe set
19. Full body wader suit	20. Fishing wader suit attached with boots	19. Full body wader suit	20. Fishing wader suit attached with boots
21. Hand gloves	22. Head lamp	21. Hand gloves	22. Head lamp
24. Helmet	24. Helmet demobilizing	24. Helmet	24. Helmet demobilizing
25. Lead acetate paper	26. Life guard pad	25. Lead acetate paper	26. Life guard pad
27. Modular airlines supply trolley system	28. Normal face mask	27. Modular airlines supply trolley system	28. Normal face mask
29. Nylon rope ladder - 5 m	29. Nylon safety belt	29. Nylon rope ladder - 5 m	29. Nylon safety belt
31. Pocket book	32. Puff oven	31. Pocket book	32. Puff oven
33. Raincoat	34. Reflecting jacket	33. Raincoat	34. Reflecting jacket
35. Safety belt	36. Safety badge clothing	35. Safety belt	36. Safety badge clothing
37. Safety body harness	38. Safety goggles	37. Safety body harness	38. Safety goggles
39. Safety gum boots	40. Safety helmets	39. Safety gum boots	40. Safety helmets
41. Safety showers	42. Safety torch	41. Safety showers	42. Safety torch
44. Safety tripod set	44. Search light	44. Safety tripod set	44. Search light

- i) Deformity or disease of the lower limbs limiting movement;
- ii) Chronic skin disease;
- iii) Serious defects in eyesight; and
- iv) Lack of sense of smell.

Employees should be medically re-examined at reasonable intervals, taking into account the person's age and duties.

12 TYPE OF INSPECTIONS AND EXAMINATIONS OF SEWERS

Inspection and examination are the techniques used to gather information to develop operation and maintenance programs to ensure that new and existing collection systems serve their intended

purposes on a continuing basis. Inspection and testing are necessary to identify existing or potential problem areas in the collection system, evaluate the seriousness of detected problems, locate the position of problems, and provide clear, concise, and meaningful reports to supervisors regarding problems. There are two basic types of inspection and examination i.e., direct and indirect described below

12.1 Direct Method

Direct method is performed through direct visual inspection by the inspector who enters into the manhole with proper safety gear as prescribed. This shall never be done once a sewer has been put into service.

11/11/10 2007/11



12.2 Indirect Method

CPII CEO's Manual on Sewerage and Sewage Treatment Systems, 2013 prescribes various methods of indirect inspection of sewer lines. Sewer system inspection technologies that are considered applicable to Indian conditions by the Manual are as follows:

Table 2

Sl. No.	Technology	Applicability	Inspection Condition
1	Light and Mirror	Up to 300 mm	Empty
2	Closed Circuit Camera	Any Size	Empty
3	Sonar Systems	Any Size	Full Flowing

12.2.1 Light and Mirror Method

Two successive manholes are opened and vented sufficiently for about an hour. Thereafter, a long hand-held mirror secured at 45 degrees to the handle is lowered into the bottom of the manhole and a torch light is focused on the mirror from above so that the light beam is deflected by 90 degrees to travel horizontally through the sewer pipe and the light is seen in the opposite manhole. This is easier at dusk. This can tell whether the bore of the pipe is choked or clear or laid straight.

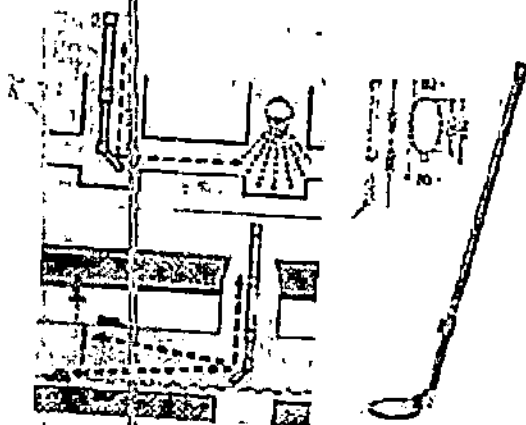

12.2.2 Closed Conduit Camera Method

The closed circuit camera is propelled through the sewer by a remote controlled wired power supply from a van and travels through the sewer and relays the picture of the inside to a TV in the van. The CCTV

inspection can be used for sewer lines as small as 100 mm. Above 900 mm diameter there are limitations due to lighting problems and camera line angles. The traction of the cameras is provided either by pulling winches, by pushing or self-traction. The former two are not used much at present. However, self-traction is suitable for use in sewers above 225 mm diameter.

12.2.3 Sonar System

The sonar system is similar. A robot is sent through the sewer and it emits high frequency sound waves, which impinge on the pipe surfaces and returns to the emitter as a reflection. By knowing the material of construction of the sewer pipe walls, this can be programmed to verify the structural condition of the wall of the sewers.



Photographs showing Structural Damage and Longitudinal cracked condition of the Sewer

13. METHODS OF CLEANING SEWERS AND SEPTIC TANKS

Mechanical means of cleaning sewers is most preferred method and shall be employed wherever possible. Manual entry into the sewers shall be avoided as far as possible and shall be employed only in inevitable cases, that too with proper protective gears & other cleaning devices and ensuring observance of safety precautions. In no case hazardous cleaning of sewers shall be entertained by the ULBs or by private contractors as Prohibition of Employment as Manual Scavengers and their Rehabilitation Act, 2013 completely ban of hazardous cleaning of sewers.

Most often desludging machines and jetting/suction machines are employed by larger ULBs in the Country for cleaning their sewers. Various sewer cleaning methods are described in the CPII CEO Manual on Sewerage and Sewage Treatment Systems, 2013. Some of them are described below. However, the Manual may be referred for further information in this regard.

True copy!!
130

This consists of a machine, which rotates a flexible rod to which is attached a cleaning tool such as auger, scraper or hooking and steel cups. The flexible

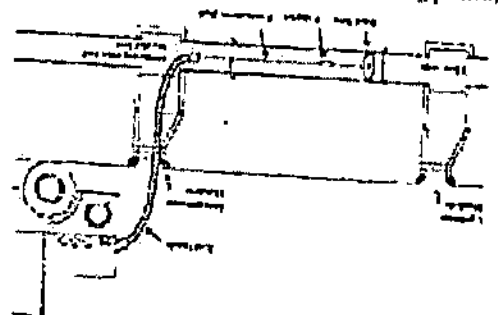

13.2 Rodding Machine with Flexible Sewer Rods

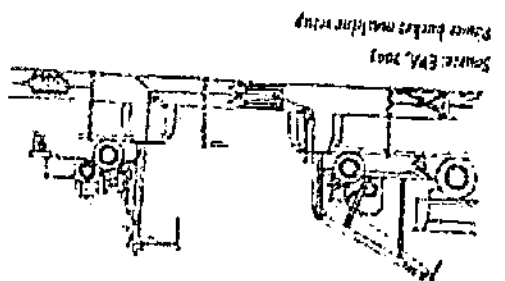

13.1 Mechanical Methods
 13.1.1 Sewer Cleaning Bucket Machine
 The bucket machine consists of two powered wheels with cables in between. For cleaning a section of sewer, the wheels are centered over two adjacent manholes. To get the cable from one manhole to the other, it is necessary to thread the cable through split-bamboo rods. The cable from the drum of each wheel is fastened to the barrel on each end of an expansion sewer bucket fixed with closing device so that the bucket can be pulled in either direction by the machine on the appropriate end. The bucket is pulled into the loosened material to clean the sewer.

top of the scraper will also assist in pushing it in the forward direction. This means that the bottom and the sides of the sewer are cleaned thoroughly. The scraped debris are removed manually.

13.1.3 Scurper
 The scurper is an assembly of wooden planks of slightly smaller size than the sewer to be cleaned. The scurper is attached to a control chain in the manhole in which it is lowered, and then connected to a winch on the next downstream manhole by means of a rope. The work is then operated in pairs of men. The scurper is then operated in pairs of men. The debris ahead of the scurper. The upward flow behind the scurper and the water dripping from the

the front of the advancing end of the sewer rod is generally fitted with a brush, a rubber ring for cleaning of a cutting edge to cut and dislodge the obstruction. These rods are also useful to locate the position of a sewer that has to be exposed for attending to the problem.

13.1.2 Sectional Sewer Rods
 These rods are used for cleaning small sewers. The sewer rods may be of bamboo or teak wood or light metal usually about one-meter long at the end of which is a coupling, which remains intact in the sewer and can be easily displaced in the manhole. Sections of the rods are pushed down the sewer.

13.1.4 Manila Rope and Cloth Ball
 The most common way of clearing small diameter sewers up to few mm diameter is by the use of a manila rope and cloth ball. Flexible bamboo strips are inserted in the sewer line by a person on top. If necessary, another person handles the manhole with full safety gear, precautionary measures and safety equipment help in pushing the rope through the sewer line. When the front end of the bamboo strip reaches the next manhole, a thick manila rope, with cloth ball at one end, is tied to the rear end of the bamboo strip. The bamboo strips are then pulled by another person in the downstream manhole and pushed through the sewer line. As the rope is pulled, the ball sweeps the sewer line and the accumulated grit is carried to the next manhole where it is removed out by means of buckets. This operation is repeated between the next manholes until the stretch of sewer line is cleared. This again requires careful supervision.

13.1 Manual Methods

rod is guided through the manhole by a bent pipe. The machine propels the rod with the tool attached to one end, the other end being fixed to the machine. The rod is pulled in and out in quick succession when the tool is engaging the obstruction, so as to dislodge or loosen it. When the obstruction is cleared, the rod is pulled out by means of clamps keeping the rod propelled to facilitate quick and easy removal.

13.2.3 Hydraulically Propelled Devices

The hydraulically propelled devices take advantage of the force of impounded water to effectively clear sewers. The efficiency depends on the hydraulic principle, that an increase in velocity in a moving stream is accompanied by a greatly increased ability to move entrained material. The transporting capacity of water varies as the sixth power of its velocity. The common hydraulically propelled devices are as follows:

- (i) Flush Bags
- (ii) Sewer Balls
- (iii) Sewer Scooters

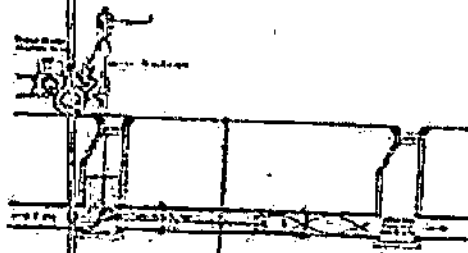

Typical Setup for Hydraulic cleaning using Sewer Ball

13.2.4 Velocity Cleaners (Jetting Machines)

The high velocity sewer-cleaner makes use of high velocity water-jets to remove and dislodge obstructions. It combines the functions of a rodding machine and gully emptier machine. It includes a high-pressure hydraulic pump capable of delivering water at variable pressure up to about 8 MPa through a flexible hose to a sewer cleaning nozzle. The nozzle has one forward facing jet and a number of peripheral rearward facing jets. The high-pressure water coming out of the holes with a high velocity, breaks up, dislodges the obstructions and flushes the materials down the sewer. Moreover, by varying the pressure suitably, the nozzle itself acts as a jack-hammer and

breaks up stubborn obstructions. A separate suction pump or airflow device may also be used to suck the dislodged material. The entire equipment is usually mounted on a heavy truck chassis with either a separate prime mover or a power take off for the suction device. The truck carries secondary treated sewage, if available, and if not untreated fresh water for the hydraulic jet. The truck also has a tank for the removed sludge and various controls grouped together for easy operation during sewer cleaning.

Now-a-days, Mini jetting machines are also available in the market which can travel into narrow lanes and clean the sewer lines up to a length of 200 feet (60 meters).

13.2.5 Dredger (Clam-shell) - for manhole cleaning

It consists of a grab bucket on a wire rope, which is lowered into the manhole in an open condition with the help of a crane and pulley. On reaching the bottom of the manhole, the segments are closed, and the accumulated silt is picked up. The bucket can be closed by wire ropes or by a pneumatically operated cylinder.

13.2.6 Gully Emptier (Suction Units)

Suction units create the vacuum required for siphoning of mud, slurry, grit and other materials. The vacuum elevated is such as to siphon the materials from the deep manholes catch-pits etc. having depth ranging from 1m to 8m in normal cases with an option to suck an additional 4m with the help of special accessories for the purpose. The unit can be vehicle or trolley mounted. Silt and heavy particles settled at the bottom can be agitated and loosened by pressurized air with the help of the pump and then sucked in a tank.

14 ROLES & RESPONSIBILITIES

14.1 Urban Local Bodies (ULBs)

1. ULBs shall authorize the Agencies for providing the cleaning of sewers and septic tanks by mechanical means or by manual means, in case, for private as well as public sewerage systems including pumping wells.

//True copy//

- ii. A list of registered Agencies along with full contact details, trained manpower, availability of equipments, and others shall be made available in public domain;
 - iii. ULBs must conduct survey to identify manual scavengers/ sanitation workers (hazardous cleaning) in their jurisdiction and frame a mechanism to rehabilitate or integrate them to the system formally;
 - iv. The supervisor of the sewer cleaning activity shall be properly trained on the first aid and cardiopulmonary resuscitation procedures by the ULB;
 - v. All the workers involved in cleaning shall be familiarized with the operating procedures of cleaning equipment and emergency procedures by the ULBs;
 - vi. Sewerage system may be mapped on Global Positioning System (GPS) so as to identify and reach the complaint area and perform the activities at the earliest;
 - vii. Training programs on the technique, equipment operation and emergency procedures shall be conducted for them once in every two years;
 - viii. Sufficient copies of the operating procedures of the cleaning machines/ equipment shall be maintained by the ULBs in local language and the copies of the same shall be made available to the field staffs;
 - ix. ULBs shall ensure that all cleaning staff undergoes regular medical checkups and administered vaccinations as deemed appropriate, and shall maintain proper records of the same;
 - x. ULBs shall ensure the staffs engaged for cleaning sewers/septic tanks has a life insurance policy for at least Rs. 10 lakhs, for which the premium shall be paid by the employer;
 - xi. ULBs shall maintain the complete contact details of the owners of cleaning machines/vehicles operating in their jurisdiction and ensure all the septage collected by them is emptied only at the designated sites;
 - xii. ULBs shall also be responsible for any negligence of the Registered Agencies/ Contractor/ Employers;
 - xiii. ULBs are responsible for providing proper equipment, in case of direct involvement of ULBs in cleaning process;
 - xiv. ULBs shall coordinate emergency activity with local authorities, in case of any emergencies to the crew members while cleaning sewers/septic tanks; and
 - xv. ULBs shall develop and put forth a mechanism to receive/register the grievances/concerns of the cleaning staffs and resolve them as soon as possible.
- 14.2 Registered Agencies/Contractors/Employers
- i. Registered Agencies/Contractors/Employers shall provide adequate safety gears and cleaning devices as prescribed in the SOP and the Rules;
 - ii. Registered Agencies/Contractors/Employers are responsible for paying premium for life insurance of the staffs assigned with him/her for cleaning of sewers/septic tanks;
 - iii. In consultation with ULBs, registered agencies/contractors shall ensure that all cleaning staffs undergoes regular medical checkups and administered vaccinations as deemed appropriate; and
 - iv. Registered Agencies/Contractors/Employers shall ensure that all cleaning staffs are adequately trained and familiarized with the operating procedures of cleaning equipment and emergency procedures.
- 14.3 Employees
- i. Employees must familiarize them with the SOP and follow the procedures to ensure the personal safety and the safety of others.
 - ii. In case of any doubt in the operating procedures of cleaning equipment and emergency procedures or inadequate training, the employee shall report the same to the concerned authorities.
 - iii. Employees should, despite their discomfort, use all the necessary safety gears and cleaning devices when employed in cleaning sewers/septic tanks.
 - iv. Employees without the knowledge and consent of the competent authority shall not involve in cleaning of sewers/septic tanks.

13.4 Individuals

- i. Any individual person shall not engage person for cleaning of sewers/ septic tank in their premises on their own;
- ii. Individual shall always hire/employ the cleaning workers only through their ULBs or Authorized Agencies/designated agencies by ULB.

- iii. Individual shall inform to the ULBs officials in case of any casualty;
- iv. Individual shall keep the site free from any hazard, which can injure the workforce.

//True copy//

True copy

134

Terminology

Act: The Prohibition of Employment as Manual Scavengers and Their Rehabilitation Act, 2003.

Cleaning Device: This includes but not limited to the equipment referred to in Rule 5 whether manually or mechanically propelled which can be used to:

- (i) Clean or enable the transport or flow of sewage in sewers or seepage from septic tanks and
- (ii) Avoid direct manual contact with such sewage or material

Faecal Sludge: The accumulated semi-solid or solid portion that settled at the bottom of the septic tank which comprising zone - some of the total septic tank volume is termed as faecal sludge.

Hazardous Cleaning: Hazardous cleaning by an employee, in relation to a sewer or septic tank, means his manual cleaning by such employee without the employer fulfilling his obligations to provide protective gear and other cleaning devices and ensuring observance of safety precautions, as may be prescribed or provided in any other law, for the time being in force or rules made thereunder.

Local Authority: Local Authority means, (i) a Municipality or a Panchayat, as defined in clause (e) and clause (f) of the Constitution, which is responsible for sanitation in its area of jurisdiction; (ii) a Government Board constituted under section 10 of the Government Act, 2003; and a railway authority;

Manual Scavenger: Manual scavenger means a person engaged or employed, at the commencement of this Act or at any time thereafter, by an individual or a legal authority or an agency or a contractor for manually clearing, carrying, disposing of, or otherwise handling in any manner, human excreta in an insanitary latrine or in an open drain or pit into which the human excreta from the insanitary latrine is disposed of, or on a railway track or in such other spaces or

premises, as the Central Government or a State Government may notify, before the exercise fully determines in such manner as may be prescribed, and the expression "manual scavenging" shall be construed accordingly.

Protective Gear: These are the personal safety gear and safety devices that are to be provided, worn or used by safe karamcharis or sanitary workers in respect of cleaning of sewers and septic tanks that may be necessary for the specific nature of work to be carried out, as including and not limited to the materials which can lead to diseases, along with all breathing equipment which prevents inhalation of gases which can lead to diseases, and also includes any sensory equipment for detection of gases present inside the sewers or septic tanks.

(ii) Avoid any injuries while carrying out cleaning work.

Rule: Prohibition of Employment as Manual Scavengers and their Rehabilitation Rules, 2013.

Safety Precautions: The precautions shall include but not be limited to the precautions referred to in Rule 6 and are all steps necessary to reduce the risk to the person and to avoid contraction of diseases and injuries by the persons engaged in cleaning of sewers and emptying of septic tanks due to exposure to sewage or any other material in any physical state (solid, liquid or gas) inside the sewers or septic tanks and while entering sewers or septic tanks.

Septage: Septage is the liquid and solid material that is pumped from a septic tank, cesspool, or such other treatment facility after it has accumulated over a period of time. Septage is the combination of sludge, sludge, and liquid that accumulates in septic tanks. Offensive odour and appearance are the most prominent

True Convill
135

Characteristics of Septage: It is a host of many disease-causing organisms along with the contamination of significant level of grease, grit, hair, and debris.

Septic Tank: Septic tank means a water-tight settling tank or chamber, normally located underground, which is used to receive and hold human excreta, allowing it to decompose through bacterial activity.

Sewage: Sewage is defined as the wastewater containing human body waste matter (faeces and urine, etc), either dissolved or undissolved, discharged from toilets and other receptacles intended to receive or retain such human body wastes.

Sewer: Sewer means an underground conduit or pipe for carrying off human excreta, besides other waste matter and drainage wastes.

Sewerage System: The underground conduit for the collection of sewage is called sewer. A network of sewer appurtenances intended for the collection and conveyance of sewage generated from each of the properties to a sewage pumping station for pumping to sewage treatment plant for further treatment and disposal is called sewerage system.

//True copy//

Unless otherwise specified, the above terminology shall remain valid in this SOP

Annexure-I

Checklist for Minimum constituents of the first aid kit that shall be made readily available to the staffs employed in sewer cleaning at the site.

1	Small sterilized dressings.	6	<input type="checkbox"/>
2	Medium size sterilized dressings.	3	<input type="checkbox"/>
3	Large size sterilized dressings.	3	<input type="checkbox"/>
4	Large sterilized burn dressings.	3	<input type="checkbox"/>
5	Bottle (50 ml) containing a two percent alcoholic solution of Iodine.	1	<input type="checkbox"/>
6	Bottle (50 ml) containing salicylate having the dose & mode of administration indicated on the label.	1	<input type="checkbox"/>
7	Snakebite lance.	1	<input type="checkbox"/>
8	Bottle (50 gm) of potassium permanganate crystals.	1	<input type="checkbox"/>
9	Plastic syringe.	1	<input type="checkbox"/>
10	Copy of the first aid leaflet issued by the Director General Factory Advice Service and Labour Institutes Government of India.	1	<input type="checkbox"/>
11	Bottle containing 100 tablets (each of 5 gm) of aspirin.	1	<input type="checkbox"/>
12	Disinfectant for burns.	1	<input type="checkbox"/>
13	Bottle of suitable surgical aseptic solution.	1	<input type="checkbox"/>

//True copy//



Annexure-III

Checklist for Training Methods			
Depth < 2m		Depth > 2m	
Checklist	Yes/No	Checklist	Yes/No
Personal Safety		Personal Safety	
Helmet with headlight		Helmet with headlight	
Gum Boots		Gum Boots	
Waterproof Clothing		Waterproof Clothing	
Gloves		Gloves	
Safety Belt		Safety Belt	
Oxygen Mask		Oxygen Mask	
Chemical Cartridge Mask		Chemical Cartridge Mask	
Oil		Oil	
Soap		Soap	
Towel		Towel	
Oxygen Cylinder		Oxygen Cylinders	
Tools		Tools	
Barricade		Barricade	
Rope Ladder/Tripod with Chain Pulley		Tripod with Chain Pulley	
Silt Grabber		Silt Grabber	
Chrome-Flexible Steel Rod		Chrome-Flexible Steel Rod	
Bucket with Rope		Bucket with Rope	
Spade with long handle		Spade with long handle	
Crowbar		Crowbar	
Trolley		Trolley	
First Aid Kit		First Aid Kit	
Alphale Key Rod		Alphale Key Rod	

//True copy//

ਪੰਜਾਬ ਵਾਟਰ ਸਪਲਾਈ ਅਤੇ ਸੀਵਰੇਜ ਬੋਰਡ
ਪਲਾਟ ਨੰ: 1-ਬੀ, ਮੈਕਟਰ 27-ਏ, ਚੰਡੀਗੜ੍ਹ।

ਇੰਜੀਨੀਅਰ-ਇਨ-ਚੀਫ
ਕਮ ਟੈਕਨੀਕਲ ਅਡਵਾਈਜ਼ਰ

ਮੁੱਖ ਇੰਜੀਨੀਅਰ (ਪੁਰਬ), (ਪੱਛਮ) ਅਤੇ (ਦੱਖਣ),
ਪੰਜਾਬ ਵ/ਸ ਅਤੇ ਸੀਵਰੇਜ ਬੋਰਡ,
ਪਟਿਆਲਾ, ਅੰਮ੍ਰਿਤਸਰ ਅਤੇ ਬਠਿੰਡਾ।

ਪੱਤਰ ਨੰ, ਪਵਸਸਬ-2018/O&M/Cell: 1699-21 ਮਿਤੀ 23/1/19

ਵਿਲਾ-
ਹਵਾਲਾ-

Standard Operating Procedure (SOP) for 'Cleaning of Sewers and Septic Tanks'
ਜਨਰਲ ਮੈਨੂਅਲ (ਪ੍ਰੋਜੈਕਟ), ਪੰਜਾਬ ਸਿਵਿਲਿਅਲ ਈਂਜੀਨੀਅਰਿੰਗ ਡਿਪਾਰਟਮੈਂਟ ਵੱਲੋਂ ਵਿਕਾਸ ਕੰਪਨੀ ਲੀ ਦੇ ਦਫਤਰ ਦਾ ਮੁੱਖ
ਨੰਬਰ PMDC/OGM(P)/2019/350-352 ਮਿਤੀ 15-01-2019 ਸਹਿਯੋਗ।

ਉਕਤ ਹਵਾਲੇ ਅਧੀਨ ਪੱਤਰ ਦੇ ਸੰਬੰਧ ਵਿੱਚ ਅੱਪ ਜੀ.ਨੂੰ ਖੋਲ੍ਹੀ ਕੀਤੀ ਜਾਂਦੀ ਹੈ ਕਿ ਉਕਤ SOP ਵਿੱਚ ਦਿੱਤੇ
ਹਵਾਲਿਆਂ ਦੀ ਇਨ-ਬਿਨ ਪਾਲਣਾ ਕਰਨਾ ਯਕੀਨੀ ਬਣਾਇਆ ਜਾਵੇ ਜੀ।
ਨੋਬੀ-ਉਕਤ ਅਨੁਸਾਰ।

ਕਾਰਜਕਾਰੀ ਇੰਜੀਨੀਅਰ (ਓਅੰਡਐਮ)
ਵਾਸਤੇ ਇੰਜੀਨੀਅਰ-ਇਨ-ਚੀਫ
ਕਮ ਟੈਕਨੀਕਲ ਅਡਵਾਈਜ਼ਰ

ਪਿਠ ਅੱਡਣ ਨੰ, ਪਵਸਸਬ-2018/O&M/Cell: 1699-43 ਮਿਤੀ 23/1/19

ਉਪਰੋਕਤ ਦਾ ਉਤਾਰਾ ਸ਼ੁਰੂ ਨਿਗਰਾਨ ਇੰਜੀਨੀਅਰ ਅਤੇ ਕਾਰਜਕਾਰੀ ਇੰਜੀਨੀਅਰ (ਈਲਡ ਵਿੱਚ) ਜੀ ਨੂੰ ਏਮੇਲ
ਦਾ ਰੀ ਸੂਚਨਾ ਅਤੇ ਅਗਲੇਰੀ ਕਾਰਵਾਈ ਹਿੱਤ ਭੇਜਿਆ ਜਾਂਦਾ ਹੈ ਜੀ।

ਕਾਰਜਕਾਰੀ ਇੰਜੀਨੀਅਰ (ਓਅੰਡਐਮ)
ਵਾਸਤੇ ਇੰਜੀਨੀਅਰ-ਇਨ-ਚੀਫ
ਕਮ ਟੈਕਨੀਕਲ ਅਡਵਾਈਜ਼ਰ

//True copy//



PUNJAB MUNICIPAL INFRASTRUCTURE DEVELOPMENT COMPANY
Punjab Municipal Bhawan
Plot No. 3, 5th Floor, Sector 35-A, Chandigarh - 160035, Punjab, India
Telephone: +91(172) 2619182, 183, 171
Email: contact@pmidc.com Website: <http://pmidc.punjab.gov.in>

To,

1. The Commissioner,
Municipal Corporation,
Amritsar, Jalandhar, Ludhiana, Patiala, Bathinda,
Moga, Hoshiarpur, Pathankot, S.A.S Nagar & Phagwara.
2. The Engineer-in-Chief
PWSSB, Chandigarh.
3. The Regional Deputy Director,
Local Govt. Department,
Amritsar, Jalandhar, Ludhiana,
Patiala, Bathinda & Ferozepur.

Memo.No. PMID/IGM(P)/2019/ 350-352 Dated: 15.1.2019

Sub: Standard Operating Procedure (SOP) for 'Cleaning of Sewers and Septic Tanks'.

Ministry of Housing and Urban Affairs, Govt. of India vide letter dated 18.12.2018 has released Standard Operating Procedure (SOP) for 'Cleaning of Sewers and Septic Tanks'. The SOP describes the set of procedures to be followed for cleaning of sewers and emptying of septic tanks including the precautions to be employed and the emergency preparedness. The detailed SOP is available at http://amrut.gov.in/vniteraddata/amrut_SOP.pdf. Worthy Secretary Local Govt.-cum-GEO, PMIDC has directed that all ULBs/PWSSB should strictly ensure adherence / compliance of the provisions of SOP.

General Manager (Project)

CC: EA/GEO, PMIDC

//True copy//

140

300/140
15/1/19

141

//True copy//



Rajkaj Ret 5309636
Monga
Digitally signed by Jagjeet Singh
Designation : Director
Date: 2024.01.25 17:21:58 IST
Reason: Approved

Signature Not-Verified

निदेशक एवं संयुक्त शासन सचिव

2. निजी सचिव, अति-मुख्य सचिव, साम्बासि, शासन सचिवालय जयपुर।

प्रेषित है।

1868707 दिनांक 18.12.2023 एवं 1912725 दिनांक 05.01.2024 की पालना में संयुक्त

1. निजी सचिव, संयुक्त सचिव, मुख्य सचिव कार्यालय, शासन सचिवालय जयपुर के पत्रों

प्रतिनिधि निम्न की संयुक्त एवं आवश्यक कार्रवाई हेतु :-

क्रमांक:एफ () एससीएसपी/स्वच्छकार/साम्बासि/2022-23/

जयपुर, दिनांक

निदेशक एवं संयुक्त शासन सचिव

(जगजीव सिंह मोंगा)

संलग्न:-उपरोक्त निम्न।

में विन्युक्त की गई कार्रवाई की रिपोर्ट संलग्न कर आवश्यक कार्रवाई हेतु प्रेषित है।

Others before Supreme Court of India में दिनांक 20.10.2023 को दिये गये आदेश की पालना

द्वारा Civil Writ Petition (PIL) No.324/2020 filed by Dr.Balram Singh Vs Union of India &

उपरोक्त विषयान्तर्गत संदर्भित पत्र के क्रम में माननीय सर्वोच्च न्यायालय में

महोदय,

15.12.2023 एवं 02.01.2024 के क्रम में।

संदर्भ:-आपका पत्रांक 12012/01/2023-लान दिनांक 14.11.2023,

संबंध में।

20.10.2023 को दिये गये आदेश की पालना रिपोर्ट भिजवाने के

विषय:- Civil Writ Petition (PIL) No.324/2020 filed by Dr.Balram Singh Vs

सी.जी.ओ कार्यालय लोधी रोड नई दिल्ली।

बी-2 में लाल प.दीनदयाल अन्वयित भवन

सामाजिक न्याय एवं अधिकारिता विभाग,

सामाजिक न्याय एवं अधिकारिता मंत्रालय,

उप सचिव,

क्रमांक:एफ () एससीएसपी/स्वच्छकार/साम्बासि/2022-23/

जयपुर, दिनांक

बी-3/1 अखंडकर भवन, राजमहल, रोजी-डैन्सी क्षेत्र जयपुर

सामाजिक न्याय एवं अधिकारिता विभाग,

राजस्थान सरकार



Amexu20-IV-H

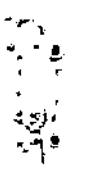



राजस्थान सरकार

सामाजिक न्याय एवं अधिकारिता विभाग,

जी-3/1 अन्वेषक भवन, राजमहल, देवीदेवरी क्षेत्र जयपुर

माननीय सर्वोच्च न्यायालय द्वारा Civil Writ Petition (PIL) No.324/2020 filed by Dr.Balram Singh Vs Union of India & Others before Supreme Court of India में दिनांक 20.10.2023 को सामाजिक न्याय एवं अधिकारिता मंत्रालय भारत सरकार को दिये गये आदेश के क्रम में मंत्रालय के पत्र दिनांक 14.11.2023, 15.12.2023 एवं 02.01.2024 द्वारा पृथा संख्या 96 (2-6), (10) एवं (12) में की गई कार्यवाही की विन्मुखार पालना रिपोर्ट :-

क्र. पृथा संख्या	माननीय सर्वोच्च न्यायालय के आदेश का विवरण
------------------	-------------------------------------------

1. 96(2)	<p>दृष्ट से मैला उठाने वाले कार्मिकों के नियोजन का प्रतिबंध और पुनर्वास अधिनियम 2013 एवं नियम 2013 के क्रियान्वयन एवं प्रावधानों की पालना शहसी एवं गामीन क्षेत्रों में न्यायालय द्वारा जारी आदेश किसे जाने हेतु समय-समय पर राज्य सरकार द्वारा समस्त जिला कलेक्टर एवं स्वायत्त शासन विभाग और पंचायतीरज विभाग को मुख्य सचिव, राजस्थान सरकार एवं शासन सचिव, सामाजिक न्याय एवं अधिकारिता विभाग की ओर से निर्देशित किया जाता रहा है।</p> <p>माननीय सर्वोच्च न्यायालय द्वारा Civil Writ Petition (PIL) No.324/2020 filed by Dr.Balram Singh Vs Union of India & Others before Supreme Court of India में दिनांक 20.10.2023 को दिये गये आदेश का क्रियान्वयन करने के संबंध में समस्त जिला कलेक्टर एवं स्वायत्त शासन विभाग और पंचायतीरज विभाग को शासन सचिव, सामाजिक न्याय एवं अधिकारिता विभाग की ओर से पत्र दिनांक 13.12.2023 एवं 04.01.2024 द्वारा निर्देशित किया जाकर पालना करवायी जा रही है।(प्रतिधा संलग्न)</p>
----------	----------------------------------------------------------------------------------------------------------------------------------------------------------------------------------------------------------------------------------------------------------------------------------------------------------------------------------------------------------------------------------------------------------------------------------------------------------------------------------------------------------------------------------------------------------------------------------------------------------------------------------------------------------------------------------------------------------------------------------------------------------------------------------------------------------------------------------------------------------------------------------------------------------------

2. 96(3)	<p>सीवरेज लाईन(मैन ड्रॉल / सैटिक टैंक सफाई) में कार्य करते हेतु दुर्घटना होने पर मृतकों के आश्रितों का पुनर्वास (निकटतम रिश्तेदारों को रोजगार, बच्चों को शिक्षा और कौशल प्रशिक्षण) करवाने हेतु कार्यवाही की जावे।</p>
----------	-----------------------------------------------------------------------------------------------------------------------------------------------------------------------------------------------------------------------

Signature Not-Verified
 Digitally signed by Jagjeet Singh Monga
 Designation : Director
 Date: 2024.01.25 11:21:58 IST
 Reason: Approved

Rajkaj Ret
5109636

142

True copy



3.	96(4)	सीवरेज लाईन (मैन हॉल/सेप्टिक टैंक सफाई) में कार्य करते हुये दुर्घटना होने पर मृतको के आश्रितों को पूर्व की राशि रूपये 10.00 लाख की बजाया में बढी हुई राशि 30.00 लाख रूपये का भुगतान किया जाये।	माननीय सर्वोच्च न्यायालय द्वारा Civil Writ Petition (PIL) No.324/2020 filed by Dr.Balram Singh Vs Union of India & Others before Supreme Court of India में दिनांक 20.10.2023 को दिये गये आदेश का क्रियान्वयन करने के संबंध में समस्त जिला कलक्टर्स एवं स्वायत्त शासन विभाग और पंचायतीराज विभाग को शासन सचिव, सामाजिक न्याय एवं अधिकारिता विभाग की ओर से पत्र दिनांक 13.12.2023 एवं 04.01.2024 द्वारा निर्देशित किया जाकर पालना करवायी जा रही है।(प्रतियां संलग्न)	
4.	96(5)	सीवरेज लाईन में कार्य करते हुये दुर्घटना में विकलांग होने पर न्यूनतम मुआवजा 10.00 लाख रूपये से कम नहीं होगा यदि विकलांगता स्थायी और पीडित को आर्थिक रूप से असहाय बना देता है तो मुआवजा राशि 20.00 लाख रूपये से कम नहीं होगी, का भुगतान करवाया जाना है।		
5.	96(6)	सीवरेज लाईन (मैन हॉल/सेप्टिक टैंक सफाई) की देखभाल एवं मरम्मत आदि के लिए अनुबन्धित फर्म के माध्यम से करवाये जाने पर यदि कोई दुर्घटना होती है तथा बिना सुरक्षा उपकरणों के सीवर लाईन के कार्य करने के दौरान दुर्घटना होती है तो संबंधित निकाय अनुबन्धित फर्म के अनुबन्ध को रद्द करने एवं मौद्रिक दायित्व का उल्लेख अनुबन्ध पत्र में किया जावे।		
6.	96(10)	सीवरेज लाईन (मैन हॉल/सेप्टिक टैंक सफाई) में कार्य करते हुये दुर्घटना के दौरान मृत्यु/विकलांग होने पर उनके आश्रितों को छात्रवृत्ति दिलवायी जावे ताकि उनको सार्थक शिक्षा प्राप्त हो सके।		
				Signature Not-Verified
				Digitally signed by Jagjeet Singh Monga Designation : Director Date: 2024.01.25 17:21:58 IST Reason: Approved

RajKaj Ref
5309636

//True copy/
143



7	96(12)	<p>राज्य व केन्द्र शासित प्रदेशों को समन्वय सुनिश्चित करने के लिए निर्देशित किया जाता है कि राज्य सफाई कर्मचारी आयोग की स्थापना के साथ, राज्य स्तरीय जिला स्तरीय समितियों के गठन के संबंध में।</p>	<p>माननीय सर्वोच्च न्यायालय द्वारा Civii Writ Petition (PIL) No.324/2020 filed by Dr.Balram Singh Vs Union of India & Others before Supreme Court of India में आदेश दिनांक 20.10.2023 की पालना में राज्य में सफाई कर्मचारियों के हितों तथा अधिकारों को बढ़ावा देने तथा सुरक्षा प्रदान करने के लिये स्वायत्त शासन विभाग की आज्ञा क्रमांक 8(ग) (1)स.क. /आयोग/नियम/डीएलबी/03/653दिनांक2 5.01.2003 द्वारा राज्य सफाई कर्मचारी आयोग का गठन किया हुआ है।</p> <p>अधिनियम 2013 की धारा 26(1) के क्रम में प्रदत्त शक्तियों के अनुसरण में प्रशासनिक सुधार (अनुभाग-3) विभाग की आज्ञा दिनांक 05.02.2015 द्वारा राज्य स्तरीय सतर्कता समिति एवं अधिनियम 2013 के सुसंगत नियम 24(1) में प्रदत्त शक्तियों के अनुसरण में प्रशासनिक सुधार (अनुभाग-3) विभाग की आज्ञा दिनांक 13.05.2016 द्वारा जिला स्तरीय एवं उपखण्ड स्तरीय सतर्कता समिति गठित है। समितियों की नियमित बैठके आयोजित कर अधिनियम के क्रियान्वयन एवं प्रावधानों की समीक्षा किये जाने हेतु समस्त जिला कलक्टरों को निर्देशित किया जाकर पालना करवायी जा रही है (प्रतियां संलग्न)</p> <p>राज्य स्तरीय सर्वेक्षण समिति एवं जिला स्तरीय सर्वेक्षण समिति समिति के गठन की पत्रावली सक्षम स्तर से अनुमोदन हेतु प्रक्रियाधीन है।</p>
---	--------	----------------------------------------------------------------------------------------------------------------------------------------------------------------------------------------------------	------------------------------------------------------------------------------------------------------------------------------------------------------------------------------------------------------------------------------------------------------------------------------------------------------------------------------------------------------------------------------------------------------------------------------------------------------------------------------------------------------------------------------------------------------------------------------------------------------------------------------------------------------------------------------------------------------------------------------------------------------------------------------------------------------------------------------------------------------------------------------------------------------------------------------------------------------------------------------------------------------------------------------------------------------------------------------------------------------------------------------------------------------------------------

//True copy//

RajKaj Ref
5309636

144

Signature Not Verified

Digitally signed by Jagjeet Singh Monga
Designation : Director
Date: 2024.01.25 17:21:58 IST
Reason: Approved

राजस्थान सरकार

सामाजिक न्याय एवं अधिकारिता विभाग,

जी-3/1 अन्वेषक भवन, राजमहल, स्टीडिन्स की क्षेत्र जयपुर

क्रमांक () एसडीसी/राजमहल/सामाजि/2021/ 5791-5823
जयपुर, दिनांक 04-01-2024

जिला कलेक्टर,

जयपुर

विषय:-Writ Petition (Civil) No. 324/2020 Dr.Balram Singh Vs. Union of India &Ors before Supreme Court of India (एम.एस.एच 2013) के संबंध में सर्वोच्च न्यायालय द्वारा दिनांक

20.10.2023 को दिये गये आदेशों की पालना बाबत।

संदर्भ:-उपरोक्त न्याय और अधिकारिता मंत्रालय भारत सरकार नई दिल्ली के पत्रांक No.U-12021/1/2023-PLAN दिनांक 14.11.2023 व 15.12.2023 एवं विभागीय पूर्व पत्रांक 9846-48 दिनांक 06.09.2022, 11017-175 दिनांक 11.10.2022, 1254-56 दिनांक 05.06.2023, 1221-53 दिनांक 05.06.2023 एवं 5124-5195 दिनांक 13.12.2023

उपरोक्त संदर्भित विषयान्तर्गत Writ Petition (Civil) No. 324/2020 Dr.Balram Singh Vs.

Union of India &Ors before Supreme Court of India (एम.एस.एच 2013) में सर्वोच्च न्यायालय के निर्णय दिनांक 20.10.2023 में दिये गये निर्देशों के विन्यु संख्या 96 (2) से 6, 10 व 12 प्रति संलग्न) की पालना में निम्नांकित कार्रवाई की जानी है:-

- **विन्यु संख्या 96(2):-** "हाथ से मैला उताने वाले कार्मिकों के नियोजन का प्रतिबंध और पुनर्वास अधिनियम 2013" के तहत मूल नालियाँ एवं मलशायों की परिसंरक्षक संकाई का निषेध है। उक्त कार्रवाई आदेश्यक संस्थात्मक सभानों/अत्याधुनिकी प्रयोगिकी सभानों से हो किया जाना है। जो कोई इन उपर्युक्त का उल्लंघन करेगा तो एम.एस.एच 2013 के तहत एक.आइ.आर.द्वारा निर्दिष्ट कर्तव्य का उल्लंघन के लिए 2 वर्ष तक का कारावास या 2 लाख रुपये जुर्माना या दोनों से दण्डनीय होगा और परचालन उल्लंघन के लिए 5 वर्ष तक का कारावास या 5 लाख रुपये जुर्माना या दोनों से दण्डनीय होगा।
- उक्त अधिनियम के प्रावधानों के क्रियान्वयन अधिनियम के अन्तर्गत अपराधों का पंजीयन एवं अभियोजन की मॉनिटरिंग के लिए जिला स्तर पर जिला कलेक्टर की अध्यक्षता में एवं उच्चस्तर अभियोजन की मॉनिटरिंग के लिए जिला स्तर पर जिला कलेक्टर की अध्यक्षता में सतर्कता समितियों का गठन प्रशासनिक स्तर पर उच्चस्तर अधिकारी की अध्यक्षता में सतर्कता समितियों का गठन प्रशासनिक स्तर पर उच्चस्तर अधिनियम के अधीन अपराधों के विचारण के लिए नगर निगम क्षेत्र में अपर जिला मजिस्ट्रेट एवं अन्य नगरीय एवं ग्रामीण क्षेत्रों के लिए उच्चस्तर मजिस्ट्रेट को न्यायिक शक्तियाँ प्रदान की जाएगी (प्रति संलग्न)।
- ग्रामीण क्षेत्रों के लिए संबंधित ग्राम पंचायतों के ग्राम सचिव (ग्राम विकास अधिकारी) व सहायी क्षेत्रों में संबंधित नगरपालिका, नगर परिषद, नगर निगम के स्वरूप निरीक्षणों को निरीक्षण नियुक्त किया जा चुका है (प्रति संलग्न)।
- "हाथ से मैला उताने वाले कार्मिकों के नियोजन का प्रतिबंध और पुनर्वास अधिनियम 2013" के प्रावधानों के उल्लंघन के अभियोगों में एम.एस.एच 2013 के अन्तर्गत एक.आइ.आर.द्वारा दण्ड करने के लिए प्रावधानों के अन्तर्गत (प्रति संलग्न)।

- "हाथ से मैला उताने वाले कार्मिकों के नियोजन का प्रतिबंध और पुनर्वास अधिनियम 2013" के प्रावधानों के उल्लंघन के अभियोगों में एम.एस.एच 2013 के अन्तर्गत एक.आइ.आर.द्वारा दण्ड करने के लिए प्रावधानों के अन्तर्गत (प्रति संलग्न)।
- "हाथ से मैला उताने वाले कार्मिकों के नियोजन का प्रतिबंध और पुनर्वास अधिनियम 2013" के प्रावधानों के उल्लंघन के अभियोगों में एम.एस.एच 2013 के अन्तर्गत एक.आइ.आर.द्वारा दण्ड करने के लिए प्रावधानों के अन्तर्गत (प्रति संलग्न)।
- "हाथ से मैला उताने वाले कार्मिकों के नियोजन का प्रतिबंध और पुनर्वास अधिनियम 2013" के प्रावधानों के उल्लंघन के अभियोगों में एम.एस.एच 2013 के अन्तर्गत एक.आइ.आर.द्वारा दण्ड करने के लिए प्रावधानों के अन्तर्गत (प्रति संलग्न)।

- "हाथ से मैला उताने वाले कार्मिकों के नियोजन का प्रतिबंध और पुनर्वास अधिनियम 2013" के प्रावधानों के उल्लंघन के अभियोगों में एम.एस.एच 2013 के अन्तर्गत एक.आइ.आर.द्वारा दण्ड करने के लिए प्रावधानों के अन्तर्गत (प्रति संलग्न)।
- "हाथ से मैला उताने वाले कार्मिकों के नियोजन का प्रतिबंध और पुनर्वास अधिनियम 2013" के प्रावधानों के उल्लंघन के अभियोगों में एम.एस.एच 2013 के अन्तर्गत एक.आइ.आर.द्वारा दण्ड करने के लिए प्रावधानों के अन्तर्गत (प्रति संलग्न)।

➤ **विन्यु संख्या 96(3):-** सीवरेज लाइन (मूल जल निरीक्षण एवं स्वच्छता विभाग) के प्रावधानों की सीमा नगर निकायों एवं स्थानीय निकायों/प्रादेशिक निकायों/राज्य निकायों/राज्य सरकार के प्रावधानों के अन्तर्गत (प्रति संलग्न)।

हाथ से मैला उताने वाले कार्मिकों के आश्रयों का पुनर्वास (निकायों के आश्रयों का पुनर्वास) के प्रावधानों के अन्तर्गत (प्रति संलग्न)।

कार्रवाई (निरीक्षण) करवाने हेतु कार्यवाही की जाएगी।

Reason: Approved

Signature valid

True copy
475

- **बिन्दु संख्या 96(4):**—सीवरेज लाईन (मैन हॉल/सेप्टिक टैंक सफाई) में कार्य करते हुये दुर्घटना होने पर मृतको के आश्रितों को पूर्व की राशि रुपये 10.00 लाख की एवज में बढी हुई राशि 30.00 लाख रुपये का भुगतान किया जाये।
- **बिन्दु संख्या 96(5):**—सीवरेज लाईन में कार्य करते हुये दुर्घटना में विकलांग होने पर न्यूनतम मुआवजा 10.00 लाख रुपये से कम नहीं होगा। यदि विकलांगता स्थायी और पीडित को आर्थिक रूप से असहाय बना देता है तो मुआवजा राशि 20.00 लाख रुपये से कम नहीं होगी, का भुगतान करवाया जाना है।
- **बिन्दु संख्या 96(6):**—सीवरेज लाईन (मैन हॉल/सेप्टिक टैंक सफाई) की देखभाल एवं मरम्मत आदि के लिए अनुबन्धित फर्म के माध्यम से करवाया जाता है तो सीवरेज मरम्मत/देखभाल संबंधी कार्य बिना सुरक्षा उपकरणों के सीवर लाईन के कार्य करने के दौरान यदि कोई दुर्घटना होती है तो संबंधित निकाय अनुबन्धित फर्म के अनुबन्ध को तत्काल रद्द करने एवं मौद्रिक दायित्व भी निश्चित किया जाये का उल्लेख अनुबन्ध पत्र में किया जावे।
- **बिन्दु संख्या 96(10):**—सीवरेज लाईन (मैन हॉल/सेप्टिक टैंक सफाई) में कार्य करते हुये दुर्घटना के दौरान मृत्यु/विकलांग होने पर उनके आश्रितों को छात्रवृत्ति दिलवायी जावे ताकि उनको सार्थक शिक्षा प्राप्त हो सके।
- **बिन्दु संख्या 96(12):**—जिला स्तरीय सतर्कता समिति व उपखण्ड स्तरीय सतर्कता समिति प्रशासनिक सुधार (अनुभाग-3) विभाग के आज्ञा दिनांक 13.05.2016 द्वारा गठित है तथा नियमों में गठित जिला एवं उपखण्ड स्तरीय समिति की त्रैमासिक बैठके नियमित रूप से आयोजित कर "हाथ से मैला उताने वाले कार्मिकों के नियोजन का प्रतिषेध और पुनर्वास अधिनियम 2013" के क्रियान्वयन एवं प्रावधान की समीक्षा की जावे।

सामाजिक न्याय एवं अधिकारिता मंत्रालय द्वारा उक्तानुसार माननीय सर्वोच्च न्यायालय क के द्वारा दिये गये निर्देशों की पालना रिपोर्ट अविलम्ब प्रस्तुत की जानी है।

अतः Writ Petition (Civil) No. 324/2020 Dr.Balram singh Vs. Union of India &Ors before Supreme Court of India (एम.एस.एक्ट 2013) में सर्वोच्च न्यायालय के द्वारा दिये गये आदेश की पालना करते हुये 10 दिवस में कार्यवाही रिपोर्ट भिजवाने का श्रम करावे ताकि सामाजिक न्याय एवं अधिकारिता मंत्रालय को माननीय न्यायालय के आदेश की पालना रिपोर्ट प्रेषित की जा सकें।

संलग्न:—उपरोक्तानुसार।

(डॉ.समित शर्मा)

शासन सचिव

जयपुर, दिनांक 04-01-2024

क्रमांक:एफ () एससीएसपी/स्वच्छकार/सान्याअधि/2021/ 5824-5825

प्रतिलिपि निम्न को सूचनार्थ एवं आवश्यक कार्यवाही हेतु :-

1. निजी सचिव, सचिव, सामाजिक न्याय और अधिकारिता मंत्रालय, नई दिल्ली 110001
2. संयुक्त सचिव, मुख्य सचिव महोदय, राजस्थान, शासन सचिवालय जयपुर के पत्रांक 1868707 दिनांक 18.12.2023 के क्रम में।

Signature valid

Digitally signed by Samit Sharma
Designation: Secretary To
Government
Date: 2024.01.03 15:58:50 IST
Reason: Approved

//True copy//

- **बिन्दु संख्या 96(3):**—सीवरेज लाईन (मैन हॉल/सेप्टिक टैंक सफाई) में कार्य करते हुये दुर्घटना होने पर मृतको के आश्रितों का पुनर्वास (निकटतम रिश्तेदारों को रोजगार, बच्चों को शिक्षा और कौशल प्रशिक्षण) करवाने हेतु कार्यवाही की जावे।
- **बिन्दु संख्या 96(4):**—सीवरेज लाईन (मैन हॉल/सेप्टिक टैंक सफाई) में कार्य करते हुये दुर्घटना होने पर मृतको के आश्रितों को पूर्व की राशि रूपये 10.00 लाख की एवज में बढ़ी हुई राशि 30.00 लाख रूपये का भुगतान किया जाये।
- **बिन्दु संख्या 96(5):**—सीवरेज लाईन में कार्य करते हुये दुर्घटना में विकलांग होने पर न्यूनतम मुआवजा 10.00 लाख रूपये से कम नहीं होगा। यदि विकलांगता स्थायी और पीड़ित को आर्थिक रूप से असहाय बना देता है तो मुआवजा राशि 20.00 लाख रूपये से कम नहीं होगी, का भुगतान करवाया जाना है।
- **बिन्दु संख्या 96(6):**—सीवरेज लाईन (मैन हॉल/सेप्टिक टैंक सफाई) की देखभाल एवं मरम्मत आदि के लिए अनुबन्धित फर्म के माध्यम से करवाया जाता है तो सीवरेज मरम्मत/देखभाल संबंधी कार्य बिना सुरक्षा उपकरणों के सीवर लाईन के कार्य करने के दौरान यदि कोई दुर्घटना होती है तो संबंधित निकाय अनुबन्धित फर्म के अनुबन्ध को तत्काल रद्द करने एवं मौद्रिक दायित्व भी निश्चित किया जाये का उल्लेख अनुबन्ध पत्र में किया जावे।
- **बिन्दु संख्या 96(10):**—सीवरेज लाईन (मैन हॉल/सेप्टिक टैंक सफाई) में कार्य करते हुये दुर्घटना के दौरान मृत्यु/विकलांग होने पर उनके आश्रितों को छात्रवृत्ति दिलवायी जावे ताकि उनको सार्थक शिक्षा प्राप्त हो सके।
- **बिन्दु संख्या 96(12):**—जिला स्तरीय सतर्कता समिति व उपखण्ड स्तरीय सतर्कता समिति प्रशासनिक सुधार (अनुभाग-3) विभाग के आज्ञा दिनांक 13.05.2016 द्वारा गठित है तथा नियमों में गठित जिला एवं उपखण्ड स्तरीय समिति की त्रैमासिक बैठके नियमित रूप से आयोजित कर "हाथ से मैला उठाने वाले कार्मिकों के नियोजन का प्रतिषेध और पुनर्वास अधिनियम 2013" के क्रियान्वयन एवं प्रावधान की समीक्षा की जावे।

सामाजिक न्याय एवं अधिकारिता मंत्रालय द्वारा उक्तानुसार माननीय सर्वोच्च न्यायालय के के द्वारा दिये गये निर्देशों की पालना रिपोर्ट अविलम्ब प्रस्तुत की जानी है।

अतः Writ Petition (Civil) No. 324/2020 Dr. Balram singh Vs. Union of India & Ors before Supreme Court of India (एम.एस.एक्ट 2013) में सर्वोच्च न्यायालय के द्वारा दिये गये आदेश हेतु संबंधित शहरी निकायों को पालना करने हेतु निर्देशित कराने का श्रम करावे।

संलग्न:—उपरोक्तानुसार।

(डॉ.समित शर्मा)

शासन सचिव

जयपुर, दिनांक 04-01-2024

क्रमांक:एफ () एससीएसपी/स्वच्छकार/सान्याअवि/2021/ 5827-5828

प्रतिलिपि निम्न को सूचनार्थ एवं आवश्यक कार्यवाही हेतु :-

1. निजी सचिव, सचिव, सामाजिक न्याय और अधिकारिता मंत्रालय, नई दिल्ली 110001
2. संयुक्त सचिव, मुख्य सचिव महोदय, राजस्थान, शासन सचिवालय, जयपुर, के पत्रांक 1868707 दिनांक 18.12.2023 के क्रम में।

//True copy//

148

Signature valid

Digitally signed by Samit Sharma
Designation: Secretary To
Government
Date: 2024.01.03 15:58:50 IST
Reason: Approved

राजस्थान सरकार

सामाजिक न्याय एवं अधिकारिता विभाग,
जी-3/1 अम्बेडकर भवन, राजमहल, रेजीडेन्सी क्षेत्र जयपुर

क्रमांक एक () एससीएसपी/स्वच्छकार/सान्याअवि/2021/

5829

जयपुर, दिनांक 04-01-2024

शासन सचिव,
पंचायतीराज विभाग,
शासन सचिवालय, जयपुर राजस्थान ।

विषय:-Writ Petition (Civil) No. 324/2020 Dr.Balram singh Vs. Union of India &Ors before Supreme Court of India (एम.एस.एक्ट 2013) के संबंध में सर्वोच्च न्यायालय द्वारा दिनांक 20.10.2023 को दिये गये आदेशों की पालना बाबत ।

संदर्भ:-उपसचिव, सामाजिक न्याय और अधिकारिता मंत्रालय भारत सरकार नई दिल्ली के पत्रांक No.U-12021/1/2023-PLAN दिनांक 14.11.2023 व 15.12.2023 एवं विभागीय पूर्व पत्रांक 9846-48 दिनांक 06.09.2022, 11017-175 दिनांक 11.10.2022, 1254-56 दिनांक 05.06.2023, 1221-53 दिनांक 05.06.2023 एवं 5124-5195 दिनांक 13.12.2023

उपरोक्त संदर्भित विषयान्तर्गत Writ Petition (Civil) No. 324/2020 Dr.Balram singh Vs. Union of India &Ors before Supreme Court of India (एम.एस.एक्ट 2013) में सर्वोच्च न्यायालय के निर्णय दिनांक 20.10.2023 में दिये गये निर्देशों के बिन्दु संख्या 96 (2 से 6, 10 व 12 प्रति संलग्न) की पालना में निम्नानुसार कार्यवाही की जानी है:-

- बिन्दु संख्या 96(2):- "हाथ से मैला उठाने वाले कार्मिकों के नियोजन का प्रतिषेध और पुनर्वास अधिनियम 2013" के तहत मल नालियों एवं मलाशयों की परिसंकटमय सफाई का निषेध है। उक्त कार्य आवश्यक सुरक्षात्मक साधनों/अत्याधुनिकी प्रौद्योगिकी साधनों से ही किया जाना है। जो कोई इन उपबन्धों का उल्लंघन करेगा तो एम.एस.एक्ट 2013 के तहत एफ.आई.आर.दर्ज होगी जिसमें प्रथम उल्लंघन के लिए 2 वर्ष तक का कारावास या 2 लाख रुपये जुर्माना या दोनों से दण्डनीय होगा और पश्चातवर्ति उल्लंघन के लिए 5 वर्ष तक का कारावास या 5 लाख रुपये जुर्माना या दोनों से दण्डनीय होगा।
- उक्त अधिनियम के प्रावधानों के क्रियान्वयन अधिनियम के अन्तर्गत अपराधों का पंजीयन एवं अभियोजन की मॉनिटरिंग के लिए जिला स्तर पर जिला कलक्टर की अध्यक्षता में एवं उपखण्ड स्तर पर उपखण्ड अधिकारी की अध्यक्षता में सतर्कता समितियों का गठन प्रशासनिक सुधार (अनुभाग-3) विभाग के आज्ञा दिनांक 13.05.2016 द्वारा किया हुआ है(प्रति संलग्न)।
 - उक्त अधिनियम के अधीन अपराधों के विचारण के लिए नगर निगम क्षेत्र में अपर जिला मजिस्ट्रेट एवं अन्य नगरीय एवं ग्रामीण क्षेत्रों के लिए उपखण्ड मजिस्ट्रेट को न्यायिक शक्तियां विभागीय अधिसूचना दिनांक 03.11.2014 द्वारा प्रदत्त की जा चुकी है(प्रति संलग्न)।
 - ग्रामीण क्षेत्रों के लिए संबंधित ग्राम पंचायतों के ग्राम सेवक (ग्राम विकास अधिकारी) व शहरी क्षेत्रों में संबंधित नगरपालिका, नगर परिषद, नगर निगम के स्वास्थ्य निरीक्षकों को निरीक्षक नियुक्त किया जा चुका है (प्रति संलग्न)।
 - "हाथ से मैला उठाने वाले कार्मिकों के नियोजन का प्रतिषेध और पुनर्वास अधिनियम 2013" के प्रावधानों के उल्लंघन के अभियोगों में एम.एस.एक्ट 2013 के अन्तर्गत ही एफ आई आर दर्ज करने के निर्देश प्रदान किये जा चुके हैं।
 - "हाथ से मैला उठाने वाले कार्मिकों के नियोजन का प्रतिषेध और पुनर्वास अधिनियम 2013" के क्रियान्वयन एवं प्रावधानों की सभी नगर निकायों एवं स्थानीय निकायों में पूर्णतः पालना के लिए निर्देश जारी किए जा चुके हैं।

Signature valid

Digitally signed by Sanjay Sharma
Designation: Secretary To
Government
Date: 2024.01.03 15:58:50 IST
Reason: Approved

//True copy

149

- बिन्दु संख्या 96(3):-सीवरेज लाईन (मैन हॉल/सेप्टिक टैंक सफाई) में कार्य करते हुये दुर्घटना होने पर मृतको के आश्रितों का पुनर्वास (निकटतम रिश्तेदारों को रोजगार, बच्चों को शिक्षा और कौशल प्रशिक्षण) करवाने हेतु कार्यवाही की जावे।
- बिन्दु संख्या 96(4):-सीवरेज लाईन (मैन हॉल/सेप्टिक टैंक सफाई) में कार्य करते हुये दुर्घटना होने पर मृतको के आश्रितों को पूर्व की राशि रुपये 10.00 लाख की एवज में बढी हुई राशि 30.00 लाख रुपये का भुगतान किया जाये।
- बिन्दु संख्या 96(5):-सीवरेज लाईन में कार्य करते हुये दुर्घटना में विकलांग होने पर न्यूनतम मुआवजा 10.00 लाख रुपये से कम नहीं होगा। यदि विकलांगता स्थायी और पीडित को आर्थिक रूप से असहाय बना देता है तो मुआवजा राशि 20.00 लाख रुपये से कम नहीं होगी, का भुगतान करवाया जाना है।
- बिन्दु संख्या 96(6):-सीवरेज लाईन (मैन हॉल/सेप्टिक टैंक सफाई) की देखभाल एवं मरम्मत आदि के लिए अनुबन्धित फर्म के माध्यम से करवाया जाता है तो सीवरेज मरम्मत/देखभाल संबंधी कार्य बिना सुरक्षा उपकरणों के सीवर लाईन के कार्य करने के दौरान यदि कोई दुर्घटना होती है तो संबंधित निकाय अनुबन्धित फर्म के अनुबन्ध को तत्काल रद्द करने एवं मौद्रिक दायित्व भी निश्चित किया जाये का उल्लेख अनुबन्ध पत्र में किया जावे।
- बिन्दु संख्या 96(10):-सीवरेज लाईन (मैन हॉल/सेप्टिक टैंक सफाई) में कार्य करते हुये दुर्घटना के दौरान मृत्यु/विकलांग होने पर उनके आश्रितों को छात्रवृत्ति दिलवायी जावे ताकि उनको सार्थक शिक्षा प्राप्त हो सके।
- बिन्दु संख्या 96(12):-जिला स्तरीय सतर्कता समिति व उपखण्ड स्तरीय सतर्कता समिति प्रशासनिक सुधार (अनुभाग-3) विभाग के आज्ञा दिनांक 13.05.2016 द्वारा गठित है तथा नियमों में गठित जिला एवं उपखण्ड स्तरीय समिति की त्रैमासिक बैठके नियमित रूप से आयोजित कर "हाथ से मैला उटाने वाले कार्मिकों के नियोजन का प्रतिषेध और पुनर्वास अधिनियम 2013" के क्रियान्वयन एवं प्रावधान की समीक्षा की जावे।

सामाजिक न्याय एवं अधिकारिता मंत्रालय द्वारा उक्तानुसार माननीय सर्वोच्च न्यायालय के के द्वारा दिये गये निर्देशों की पालना रिपोर्ट अविलम्ब प्रस्तुत की जानी है।

अतः Writ Petition (Civil) No. 324/2020 Dr.Balram singh Vs. Union of India &Ors before Supreme Court of India (एम.एस.एक्ट 2013) में सर्वोच्च न्यायालय के द्वारा दिये गये आदेश हेतु संबंधित पंचायतीराज संस्थाओं को पालना करने हेतु निर्देशित कराने का श्रम करावे।

संलग्न:-उपरोक्तानुसार।

(डॉ.समित शर्मा)

शासन सचिव

जयपुर, दिनांक 04-01-2024

क्रमांक एफ () एससीएसपी/स्वच्छकार/सान्याअवि/2021/ 5830-5831

प्रतिलिपि निम्न को सूचनार्थ एवं आवश्यक कार्यवाही हेतु :-

1. निजी सचिव, सचिव, सामाजिक न्याय और अधिकारिता मंत्रालय, नई दिल्ली 110001
2. संयुक्त सचिव, मुख्य सचिव महोदय, राजस्थान, शासन सचिव, जयपुर, पिन कोड 306007 दिनांक 18.12.2023 के क्रम में।

//True copy//

Signature valid

Digitally signed by Samit Sharma
Designation: Secretary To
Government of Rajasthan
Date: 2024.01.03 15:58:50 IST
Reason: Approved

150

राजस्थान सरकार

सामाजिक न्याय एवं अधिकारिता विभाग,
जी-3/1 अम्बेडकर भवन, राजमहल, रेजीडेन्सी क्षेत्र जयपुर

क्रमांक.एफ () एससीएसपी / स्वच्छकार / सान्याअवि / 2021 / 5124 5126

जयपुर, दिनांक 13/12/2023

जिला कलक्टर,

समस्त.....।

विषय:—Writ Petition (Civil) No. 324/2020 Dr.Balram singh Vs. Union of India &Ors before Supreme Court of India (एम.एस.एक्ट 2013) के संबंध में।

संदर्भ:—उपसचिव, सामाजिक न्याय और अधिकारिता मंत्रालय भारत सरकार नई दिल्ली के पत्रांक No.U-12021/1/2023-PLAN दिनांक 4.11.2023 एवं विभागीय पूर्व पत्रांक 9846-48 दिनांक 06.09.2022, 11017-175 दिनांक 11.10.2022, 1254-56 दिनांक 05.06.2023 एवं 1221-53 दिनांक 05.06.2023

उपरोक्त विषयान्तर्गत संदर्भित पत्र उपसचिव, सामाजिक न्याय और अधिकारिता मंत्रालय भारत सरकार नई दिल्ली के द्वारा Writ Petition (Civil) No. 324/2020 Dr.Balram singh Vs. Union of India &Ors before Supreme Court of India (एम.एस.एक्ट 2013) में सर्वोच्च न्यायालय के द्वारा दिये गये निर्णय के पैरा संख्या 96 के बिन्दु संख्या 2,3,4,5,6,10 व 12 की पालना हेतु निर्देशित किया गया है। (प्रति संलग्न)।

एम.एस.एक्ट 2013 की पूर्ण पालना हेतु विभागीय पत्रांक 9846-48 दिनांक 06.09.2022, 11017-175 दिनांक 11.10.2022, 1254-56 दिनांक 05.06.2023 एवं 1221-53 दिनांक 05.06.2023 द्वारा पूर्व में भी निर्देशित किया गया था सुलभ संदर्भ के लिए प्रति पुनः पूर्ण पालना हेतु संलग्न कर प्रेषित की जा रही है।

अतः Writ Petition (Civil) No. 324/2020 Dr.Balram singh Vs. Union of India &Ors before Supreme Court of India (एम.एस.एक्ट 2013) में सर्वोच्च न्यायालय के द्वारा दिये गये निर्णयानुसार पैरा संख्या 96 के बिन्दु संख्या 2,3,4,5,6,10 व 12 की पालना करते हुये जिला एवं उपखण्ड स्तर पर गठित समिति की नियमित बैठके आयोजित कर समीक्षा किये जाने का श्रम करावें।

संलग्न:—उपरोक्तानुसार।

(डॉ. समित शर्मा)

शासन सचिव

जयपुर, दिनांक 13/12/2023

क्रमांक.एफ () एससीएसपी / स्वच्छकार / सान्याअवि / 2021 / 5157-5195

प्रतिलिपि निम्न को सूचनार्थ एवं आवश्यक कार्यवाही हेतु :-

1. निजी सचिव, सचिव, सामाजिक न्याय और अधिकारिता मंत्रालय, नई दिल्ली 110001
2. निजी सचिव, शासन सचिव सान्याअवि, शासन सचिवालय जयपुर।
3. निजी सचिव, आयुक्त एवं शासन सचिव पंचायतीराज विभाग शासन सचिवालय जयपुर।
4. निजी सचिव, शासन सचिव, स्वायत्त शासन विभाग शासन सचिवालय जयपुर।
5. निजी सचिव, निदेशक एवं संयुक्त शासन सचिव, सान्याअवि जयपुर।
6. संयुक्त / उप / सहायक निदेशक, सान्याअवि, ससस्ल: रासि

Signature valid

Digitally signed by Samit Sharma
Designation: Secretary To
Government
Date: 2023.12.13 8:16:11 IST
Reason: Approved

//True copy//

करीब 150 करोड़ रुपये की अनुमानित लागत पर निर्माण कराया जा रहा है।
 इस परियोजना के अंतर्गत राजस्थान के विभिन्न जिलों में अतिरिक्त
 नियोजन समिति कायदा की शर्तों के अंतर्गत (अनुच्छेद 2015) की शर्तों
 को ध्यान में रखते हुए (अनुच्छेद 1989) अतिरिक्त (अनुच्छेद 1989)
 विभिन्न समिति कायदा की शर्तों के अंतर्गत (अनुच्छेद 2013) के
 अंतर्गत (अनुच्छेद 2013) के अंतर्गत (अनुच्छेद 2013) के अंतर्गत
 (अनुच्छेद 2013) के अंतर्गत (अनुच्छेद 2013) के अंतर्गत (अनुच्छेद 2013)

आवश्यक भूतल है, जिस आयोग द्वारा मशीन से लिया गया है।
 प्रकरणों में उक्त न्याय देय राशि का समयबद्ध भूतल नहीं हुआ है तथा कुछ में कंठ
 दिनांक 24-25 अगस्त 2022 को आयोजित समीक्षा बैठक में बताया गया है कि कुछ
 शासन विभाग द्वारा की गयी है राष्ट्रीय अनुसूचित जाति आयोग नई दिल्ली द्वारा
 मॉनिटरिंग एवं निगरानी ग्रामीण क्षेत्रों में पंचायतीराज विभाग एवं शहरी क्षेत्रों में स्वास्थ्य
 उक्त न्याय ऐसे प्रकरणों में मुआवजा राशि के पूर्ण एवं समयबद्ध भूतल की
 राशि दी जाती है।

घटित घटनाओं में मृतक के आश्रित परिवार को 10.00 लाख रुपये की मुआवजा
 निर्देशानुसार शीघ्रता कार्य (मिनटाल/स्टिक टैक सफाई) के दौरान वर्ष 1993 के बाद
 पंरिशन (सिविल) संख्या 583/2003 में जारी निर्णय दिनांक 27.03.2014 के
 उपरोक्त विषय-संबंधित माननीय सर्वोच्च न्यायालय नई दिल्ली के द्वारा रिट

विषय:-एम.एस.एच. 2013 के तहत वर्क प्रकरणों में मृतक के आश्रित परिवार को
 मुआवजा राशि का पूर्ण एवं समयबद्ध भूतल करने, लापरवाह/दोषी पाये गये
 नियोजन समिति कायदा के अंतर्गत (अनुच्छेद 2015) की शर्तों के अंतर्गत (अनुच्छेद 1989)
 जाति-जनजाति (अनुच्छेद 1989) अतिरिक्त (अनुच्छेद 2015) की शर्तों के अंतर्गत (अनुच्छेद 1989)
 को ध्यान में रखते हुए (अनुच्छेद 1989) अतिरिक्त (अनुच्छेद 1989) अतिरिक्त (अनुच्छेद 1989)

राजस्थान सरकार
 सामाजिक न्याय एवं अधिकारिता विभाग,
 जी-3/1 अन्वेषण भवन, राजमहल, जलेश्वरी क्षेत्र जयपुर



सुनिश्चित करावें ताकि माननीय राष्ट्रीय अनुसूचित जाति आयोग नई दिल्ली को अद्यतन प्रगति रिपोर्ट से अवगत करवाया जा सके।

संलग्न:-उपरोक्तानुसार।

उषा
(ऊषा शर्मा)
मुख्य सचिव

1. अति० मुख्य सचिव,
गृह विभाग,
शासन सचिवालय जयपुर।
2. प्रमुख शासन सचिव,
ग्रामीण विकास एवं पंचायतीराज विभाग,
शासन सचिवालय जयपुर।
3. शासन सचिव,
स्वायत्त शासन विभाग,
शासन सचिवालय जयपुर।

अशा.टीप. क्रमांक:एफ () एससीएसपी / स्वच्छकार / सान्याअवि / 2022-23 / 9846-48
जयपुर, दिनांक 6.9.2022

//True copy//

राजस्थान सरकार

सामाजिक न्याय एवं अधिकारिता विभाग,

जी-3/1 अम्बेडकर भवन, राजमहल, रेजीडेन्सी क्षेत्र जयपुर

क्रमांक एफ () एससीएसपी / उपखण्डकार / मान्याअधि / 2021-22 / 11017-50

जयपुर, दिनांक 11.10.2022

जिला कलक्टर,

सगस्त.....राजस्थान।

विषय:-एम.एस.एक्ट 2013 एवं माननीय उच्चतम न्यायालय के निर्देशानुसार सीवरेज लाईन/सेप्टिक टैंक सफाई कार्यों के दौरान हुए मृत्यु प्रकरणों में मृतकों का 10.00 लाख रुपये मुआवजा राशि देने एवं अधिनियम की पालना के संबंध में।

उपरोक्त विषयान्तर्गत "हाथ से मैला ढोने वाले कार्मिकों के नियोजन का प्रतिषेध और पुनर्वास अधिनियम 2013" (एम.एस.एक्ट 2013) की क्रियान्वित हेतु तथा पीटिशन (सिविल) संख्या 583/2003 में जारी निर्णय दिनांक 27.03.2014 में माननीय सर्वोच्च न्यायालय द्वारा दिये गये निर्देशों की पालना में निम्न कार्यवाही की जा चुकी है:-

1. उक्त अधिनियम के प्रावधानों के क्रियान्वयन अधिनियम के अन्तर्गत अपराधों का पंजीयन एवं अभियोजन की मॉनिटरिंग के लिए जिला स्तर पर जिला कलक्टर की अध्यक्षता में एवं उपखण्ड स्तर पर उपखण्ड अधिकारी की अध्यक्षता में सतर्कता समितियों का गठन किया जा चुका है।
2. उक्त अधिनियम के अधीन अपराधों के विचारण के लिए नगर निगम क्षेत्र में अपर जिला मजिस्ट्रेट को न्यायिक शक्तियां अधिसूचना दिनांक 30.11.2014 द्वारा प्रदत्त की जा चुकी है।
3. ग्रामीण क्षेत्रों के लिए ग्राम पंचायतों के संबंधित ग्राम सेवक (ग्राम विकास अधिकारी) व शहरी क्षेत्रों में संबंधित नगरपालिका, नगर परिषद, नगर निगम के स्वास्थ्य निरीक्षकों को निरीक्षक नियुक्त किया जा चुका है।
4. एम.एस.एक्ट 2013 के प्रावधानों के उल्लंघन के अभियोगों में एम.एस.एक्ट 2013 के अन्तर्गत ही एफ.आई.आर. दर्ज करने के निर्देश प्रदान किये जा चुके हैं।

राष्ट्रीय अनुसूचित जाति आयोग, भारत सरकार नई दिल्ली द्वारा दिनांक 24 व 25 अगस्त 2022 को राज्य स्तरीय समीक्षा बैठक के दौरान एवं दिनांक 30.09.2022 को आयोजित वी.सी. में सचिव, राष्ट्रीय सफाई कर्मचारी आयोग द्वारा इस विषय को गम्भीरता से लिया है।

"हाथ से मैला ढोने वाले कार्मिकों के नियोजन का प्रतिषेध और पुनर्वास अधिनियम 2013" के तहत मल नालियों एवं मलाशयों की परिसंकटमय सफाई का निषेध है। उक्त कार्य आवश्यक सुरक्षात्मक साधनों/अत्याधुनिकी प्रौद्योगिकी साधनों से ही किया जाना है। जो कोई इन उपबन्धों का उल्लंघन करेगा तो एम.एस.एक्ट 2013 के तहत एफ.आई.आर. दर्ज होगी जिसमें प्रथम उल्लंघन के लिए 2 वर्ष तक का कारावास या 2 लाख रुपये जुर्माना या दोनो से दण्डनीय होगा और पश्चातवर्ति उल्लंघन के लिए 5 वर्ष तक का कारावास या 5 लाख रुपये जुर्माना या दोनो से दण्डनीय होगा।

सीवरेज टैंक/सेप्टिक टैंक सफाई कार्य के दौरान मृत्यु हुई है उन प्रकरणों में इनके परिजनों को मुआवजा राशि का भुगतान की कार्यवाही शहरी क्षेत्र के लिए नगरीय निकायों द्वारा एवं

ग्रामीण क्षेत्र क लिए ग्रामीण विकास एवं पंचायतीराज विभाग के स्तर से करवायी जानी सुनिश्चित करावे।



अतः लेख है कि सीवरेज लाईन/सेप्टिक टैंक सफाई कार्य के दौरान होने वाली मीलों की जाँच कराये तथा उत्तरदायी व्यक्तियों के विरुद्ध एम.एस.एक्ट 2013 के अनुरार कार्यवाही कराये तथा पीडित परिवारों के आश्रितों को 10.00 लाख रुपये क्षतिपूर्ति राशि प्रदान किया जाना सुनिश्चितता करावे तथा पालना रिपोर्ट 15 दिवस मे गेल-आई.डी. ddscsp.sje@rajasthan.gov.in पर भिजवाने का श्रम करावे ताकि राष्ट्रीय अनुसूचित जाति आयोग एवं राष्ट्रीय सफाई कर्मचारी आयोग भारत सरकार नई दिल्ली को अवगत कराया जा सके।

संलग्न:-उपरोक्तानुसार।

381
(उप. सचिव)
मुख्य सचिव
जयपुर दिनांक 11.10.2022

क्रमांक एफ () एससीएसपी/स्वच्छकार/सान्याअवि/2021-22/11051-175
प्रतिलिपि निम्न को सूचनार्थ एवं आवश्यक कार्यवाही हेतु :-

1. निजी सचिव, माननीय अध्यक्ष महोदय, राष्ट्रीय अनुसूचित जाति आयोग, भारत सरकार खान मार्केट, लोक नायक भवन, नई दिल्ली।
2. निजी सचिव, सचिव, राष्ट्रीय सफाई कर्मचारी आयोग, भारत सरकार खान मार्केट, लोक नायक भवन, नई दिल्ली।
3. उप सचिव, मुख्य सचिव, कार्यालय शासन सचिवालय जयपुर।
4. निजी सचिव, अति. पुलिस महानिदेशक (सिविल राईट्स), पुलिस मुख्यालय लाल कौंटी जयपुर।
5. निजी सचिव, प्रमुख शासन सचिव, ग्रामीण विकास एवं पंचायतीराज विभाग शासन सचिवालय जयपुर को प्रेषित कर लेख कि ग्रामीण क्षेत्र में होने वाले मृत्यु प्रकरणों में नियमानुसार भुगतान कराये जाने एवं एम.एस.एक्ट 2013 की पालना करवाकर सूचना भिजवाने की सुनिश्चिता करवाने का श्रम करावे।
6. निजी सचिव, शासन सचिव, स्वायत्त शासन विभाग, शासन सचिवालय, जयपुर को प्रेषित कर लेख कि शहरी क्षेत्र में होने वाले मृत्यु प्रकरणों में नियमानुसार भुगतान कराये जाने एवं एम.एस.एक्ट 2013 की पालना करवाकर सूचना भिजवाने की सुनिश्चिता करवाने का श्रम करावे।
7. निजी सचिव, शासन सचिव सान्याअवि, शासन सचिवालय।
8. निजी सचिव, निदेशक, स्वायत्त शासन विभाग, जयपुर को भेजकर लेख है कि आपके अधीनस्थ नगरीय निकायों को अपने स्तर सभी एम.एस.एक्ट 2013 के प्रावधानों की पालना हेतु निर्देशित करावे।
9. निजी सचिव, मुख्य कार्यकारी अधिकारी (ग्रा.प्रको.) जिला परिषद् समस्त राजस्थान को भेजकर लेख है कि संबंधित एजेन्सी/विभाग से संपर्क कर शहरी/ग्रामीण क्षेत्रों में होने वाले मृत्यु प्रकरणों में नियमानुसार भुगतान कराये जाने एवं एम.एस.एक्ट 2013 की पालना करवाकर सूचना भिजवाने की सुनिश्चिता करें।
10. समस्त उप/सहायक निदेशक, सामाजिक न्याय एवं अधिकारिता विभाग जिला..... को भेजकर लेख है कि संबंधित एजेन्सी/विभाग से संपर्क कर शहरी/ग्रामीण क्षेत्रों में होने वाले मृत्यु प्रकरणों में नियमानुसार भुगतान कराये जाने एवं एम.एस.एक्ट 2013 की पालना करवाकर सूचना भिजवाने की सुनिश्चिता करें।

शासन सचिव

राजस्थान सरकार

सामाजिक न्याय एवं अधिकारिता विभाग,

नौ-3/1 अप्पेडकर भवन, राजमहल, रेजीडेंसी क्षेत्र जयपुर

विषय:- एम.एस.एक्ट 2013 के तहत दर्ज प्रकरणों में मृतक के आश्रित परिवार को मुआवजा राशि का पूर्ण एवं समयबद्ध भुगतान करने, लापरवाह/दोषी पाये गये नियोक्ताओं के विरुद्ध समुचित कार्यवाही करने तथा नियमानुसार अनुसूचित जाति-जनजाति (अत्याचार निवारण) अधिनियम 1989 (यथा संशोधित 2015) की धाराओं को भी एफ.आई.आर. में शामिल करने के संबंध में।

संदर्भ:- मुख्य सचिव, राजस्थान सरकार की अशा.टीप क्रमांक 9846-48 दिनांक 06.09.2022 एवं 11017-175 दिनांक 11.10.2022

उपरोक्त विषयान्तर्गत संदर्भित अशा.टीप के क्रम में अनुरोध है कि माननीय सर्वोच्च न्यायालय नई दिल्ली के द्वारा रिट पीटिशन (सिविल) संख्या 583/2003 में जारी निर्णय दिनांक 27.03.2014 के निर्देशानुसार सीवरेज कार्य (मैनहॉल/सेप्टिक टैंक सफाई) के दौरान वर्ष 1993 के बाद घटित दुर्घटनाओं में मृतक के आश्रित परिवार को 10.00 लाख रुपये की मुआवजा राशि दिये जाने का प्रावधान है।

उक्तानुसार ऐसे प्रकरणों में मृतक के आश्रितों को मुआवजा राशि का पूर्ण एवं समयबद्ध भुगतान की मॉनिटरिंग एवं निगरानी ग्रामीण क्षेत्रों में पंचायतीराज विभाग एवं शहरी क्षेत्रों में स्वायत्त शासन विभाग द्वारा की जानी है।

“हाथ से मैला ढोने वाले कार्मिकों के नियोजन का प्रतिषेध और पुनर्वास अधिनियम 2013” (एम.एस.एक्ट 2013) की क्रियान्वित हेतु तथा पीटिशन (सिविल) संख्या 583/2003 में जारी निर्णय दिनांक 27.03.2014 में माननीय सर्वोच्च न्यायालय द्वारा दिये गये निर्देशों की पालना में निम्न कार्यवाही की जा चुकी है:-

1. उक्त अधिनियम के प्रावधानों के क्रियान्वयन अधिनियम के अन्तर्गत अपराधों का पंजीयन एवं अभियोजन की मॉनिटरिंग के लिए जिला स्तर पर जिला कलक्टर की अध्यक्षता में एवं उपखण्ड स्तर पर उपखण्ड अधिकारी की अध्यक्षता में सतर्कता समितियों का गठन किया जा चुका है।
2. उक्त अधिनियम के अधीन अपराधों के विचारण के लिए नगर निगम क्षेत्र में अपर जिला मजिस्ट्रेट को न्यायिक शक्तियां अधिसूचना दिनांक 30.11.2014 द्वारा प्रदत्त की जा चुकी है।
3. ग्रामीण क्षेत्रों के लिए ग्राम पंचायतों के संबंधित ग्राम सेवक (ग्राम विकास अधिकारी) व शहरी क्षेत्रों में संबंधित नगरपालिका, नगर परिषद्, नगर निगम के स्वास्थ्य निरीक्षकों को निरीक्षक नियुक्त किया जा चुका है।

Signature valid

Digitally signed by Sarmit Sharma
Designation: Secretary To
Government
Date: 2023.06.02 15:02:43 IST
Reason: Approved

RajKaj Ref No. : 3929211

//True copy//

156



4. एम.एस.एक्ट 2013 के प्रावधानों के उल्लंघन के अभियोगों में एम.एस.एक्ट 2013 के अन्तर्गत ही एफ.आई.आर. दर्ज करने के निर्देश प्रदान किये जा चुके हैं।

“हाथ से मैला ढाने वाले कार्मिकों के नियोजन का प्रतिषेध और पुनर्वास अधिनियम 2013” के तहत मल नालियों एवं मलाशयों की परिसंकटमय सफाई का निषेध है। उक्त कार्य आवश्यक सुरक्षात्मक साधनों/अत्याधुनिकी प्रौद्योगिकी साधनों से ही किया जाना है। जो कोई इन उपबन्धों का उल्लंघन करेगा तो एम.एस.एक्ट 2013 के तहत एफ.आई.आर. दर्ज होगी जिसमें प्रथम उल्लंघन के लिए 2 वर्ष तक का कारावास या 2 लाख रुपये जुर्माना या दोनों से दण्डनीय होगा और पश्चातवर्ति उल्लंघन के लिए 5 वर्ष तक का कारावास या 5 लाख रुपये जुर्माना या दोनों से दण्डनीय होगा।

अतः “हाथ से मैला ढाने वाले कार्मिकों के नियोजन का प्रतिषेध और पुनर्वास अधिनियम 2013” (एम.एस.एक्ट 2013) की क्रियान्वित हेतु तथा पीटिशन (सिविल) संख्या 583/2003 में जारी निर्णय दिनांक 27.03.2014 में माननीय सर्वोच्च न्यायालय द्वारा दिये गये निर्देशों की पालना करवाना एवं नियमानुसार समुचित कार्यवाही करने हेतु संबंधित को निर्देशित करने का श्रम करावें।

(डॉ.समित शर्मा)
शासन सचिव

1. अति० मुख्य सचिव,
ग्रामीण विकास एवं पंचायतीराज विभाग,
शासन सचिवालय जयपुर।
2. प्रमुख शासन सचिव,
नगरीय विकास एवं आवासन विभाग
3. शासन सचिव,
स्वायत्त शासन विभाग,
शासन सचिवालय जयपुर।

अशा.टीप. क्रमांक:एफ () एससीएसपी/ स्वच्छकार /सान्याअवि/2022-23/ 12.54 - 56
जयपुर, दिनांक 05/06/2023

Signature valid

Digitally signed by Sanat Sharma
Designation: Secretary To
Government
Date: 2023.06.02 15:02:43 IST
Reason: Approved

RajKaj Ref No. : 3929211

//True copy//

157



राजस्थान सरकार

सामाजिक न्याय एवं अधिकारिता विभाग,

सी-3/1 अखंडवन भवन, राजगहल, रेवीडेन्सी क्षेत्र जयपुर

क्रमांकएफ () एससीएसपी / स्वच्छकार /साप्ताश्रि/2022-23 / 1221-53
जिला कलाक्टर समस्त
राजस्थान।

जयपुर, दिनांक 5/6/2023

विषय:- एम.एस.एक्ट 2013 के तहत दर्ज प्रकरणों में मृतक के आश्रित परिवार को मुआवजा राशि का पूर्ण एवं समयबद्ध भुगतान करने, लापरवाह/दोषी पाये गये नियोकताओं के विरुद्ध समुचित कार्यवाही करने तथा नियमानुसार अनुसूचित जाति-जनजाति (अत्याचार निवारण) अधिनियम 1989 (यथा संशोधित 2015) की धाराओं को भी एफ.आई.आर. में शामिल करने के संबंध में।

संदर्भ:-मुख्य सचिव, राजस्थान सरकार की अशा.टीप क्रमांक 9846-48 दिनांक 06.09.2022 एवं 11017-175 दिनांक 11.10.2022

उपरोक्त विषयान्तगत संदर्भित अशा.टीप के क्रम में अनुरोध है कि माननीय सर्वोच्च न्यायालय नई दिल्ली के द्वारा रिट पीटिशन (सिविल) संख्या 583/2003 में जारी निर्णय दिनांक 27.03.2014 के निर्देशानुसार सीवरेज कार्य (मैनहॉल/सेप्टिक टैंक सफाई) के दौरान वर्ष 1993 के बाद घटित दुर्घटनाओं में मृतक के आश्रित परिवार को 10.00 लाख रुपये की मुआवजा राशि दिये जाने का प्रावधान है।

उक्तानुसार ऐसे प्रकरणों में मृतक के आश्रितों को मुआवजा राशि का पूर्ण एवं समयबद्ध भुगतान की मॉनिटरिंग एवं निगरानी ग्रामीण क्षेत्रों में पंचायतीराज विभाग एवं शहरी क्षेत्रों में स्वायत्त शासन विभाग द्वारा की जानी है।

“हाथ से भेला ढोने वाले कार्मिकों के नियोजन का प्रतिषेध और पुनर्वास अधिनियम 2013” (एम.एस.एक्ट 2013) की क्रियान्वित हेतु तथा पीटिशन (सिविल) संख्या 583/2003 में जारी निर्णय दिनांक 27.03.2014 में माननीय सर्वोच्चय न्यायालय द्वारा दिये गये निर्देशों की पालना में निम्न कार्यवाही की जा चुकी है:-

1. उक्त अधिनियम के प्रावधानों के क्रियान्वयन अधिनियम के अन्तर्गत अपराधों का पंजीयन एवं अभियोजन की मॉनिटरिंग के लिए जिला स्तर पर जिला कलाक्टर की अध्यक्षता में एवं उपखण्ड स्तर पर उपखण्ड अधिकारी की अध्यक्षता में सतर्कता समितियों का गठन किया जा चुका है।
2. उक्त अधिनियम के अधीन अपराधों के विचारण के लिए नगर निगम क्षेत्र में अपर जिला मजिस्ट्रेट को न्यायिक शक्तियां अधिसूचना दिनांक 30.11.2014 द्वारा प्रदत्त की जा चुकी है।

Digitally signed by Samal Sharma
Designation: Secretary To
Government
Date: 2023.06.08 15:03:03 IST
Reason: Approved

True copy

158

3. ग्रामीण क्षेत्रों के लिए ग्राम पंचायतों के संबंधित ग्राम सेवक (ग्राम विकास अधिकारी) व शहरी क्षेत्रों में संबंधित नगरपालिका, नगर परिषद, नगर निगम के स्वास्थ्य निरीक्षकों को निरीक्षक नियुक्त किया जा चुका है।
4. एम.एस.एक्ट 2013 के प्रावधानों के उल्लंघन के अभियोगों में एम.एस.एक्ट 2013 के अन्तर्गत ही एफ.आई.आर. दर्ज करने के निर्देश प्रदान किये जा चुके हैं।

“हाथ से मैला ढोने वाले कार्मिकों के नियोजन का प्रतिषेध और पुनर्वास अधिनियम 2013” के तहत मल नालियों एवं मलाशयों की परिसंकटमय सफाई का निषेध है। उक्त कार्य आवश्यक सुरक्षात्मक साधनों/अत्याधुनिकी प्रौद्योगिकी साधनों से ही किया जाना है। जो कोई इन उपबन्धों का उल्लंघन करेगा तो एम.एस.एक्ट 2013 के तहत एफ.आई.आर. दर्ज होगी जिसमें प्रथम उल्लंघन के लिए 2 वर्ष तक का कारावास या 2 लाख रुपये जुर्माना या दोनों से दण्डनीय होगा और पश्चातवर्ति उल्लंघन के लिए 5 वर्ष तक का कारावास या 5 लाख रुपये जुर्माना या दोनों से दण्डनीय होगा।

अतः “हाथ से मैला ढोने वाले कार्मिकों के नियोजन का प्रतिषेध और पुनर्वास अधिनियम 2013” (एम.एस.एक्ट 2013) की क्रियान्वित हेतु तथा पीटिशन (सिविल) संख्या 583/2003 में जारी निर्णय दिनांक 27.03.2014 में माननीय सर्वोच्च न्यायालय द्वारा दिये गये निर्देशों की पालना करवाना एवं नियमानुसार समुचित कार्यवाही करने हेतु संबंधित को निर्देशित करने का श्रम करावें।

(डॉ. समित शर्मा)
शासन सचिव

True copy
/

Signature valid

Digitally signed by Samit Sharma
Designation: Secretary To
Government
Date: 2023.06.02 15:03:03 IST
Reason: Approved

पत्रिका Ref No. : 3966079

राजस्थान सरकार
सामाजिक न्याय एवं अधिकारिता विभाग,
जी-3/1 अम्बेडकर भवन, राजमहल, रेजीडेन्सी क्षेत्र जयपुर

क्रमांक एफ. () एससीएसपी / स्वच्छकार / साम्याअधि / 2021 / 2410-32

जयपुर, दिनांक 21.7.2023

जिला कलक्टर,

समस्त राजस्थान।

विषय:-एम.एस.एक्ट 2013 एवं माननीय सर्वोच्च न्यायालय द्वारा याचिका संख्या

583/2003 में दिये गये निर्णय दिनांक 27.03.2014 की पालना के संबंध में।

संदर्भ:-मुख्य सचिव, महोदय का पत्रांक 11017-50 दिनांक 11.10.2022 एवं
विभागीय पत्रांक 1221-53 दिनांक 05.06.2023

उपरोक्त संदर्भित विषयान्तर्गत 'हाथ से मैला ढोने वाले कर्मियों का नियोजन का प्रतिषेध और पुनर्वास अधिनियम 2013 की क्रियान्वित एवं माननीय सर्वोच्च न्यायालय की रिट पिटीशन संख्या 583/2003 में निर्णय दिनांक 27.03.2014 की पालना किये जाने हेतु निवेदन किया गया था (संदर्भित पत्रों की प्रति संलग्न)

उक्त निर्देशों के उपरान्त भी राज्य में दिनांक 06.05.2023 को पाली में तीन, दिनांक 13.05.2023 को जोधपुर में एक, दिनांक 07.06.2023 को कोटा में तीन, दिनांक 14.07.2023 को भिवाडी अलवर में एक एवं उदयपुर में दो सफाई कर्मियों की सैण्टिक टैंक/सीवरेज लाईन की सफाई का कार्य करने के दौरान हुई दुर्घटना से मृत्यु होने को मदेनजर रखते हुये एम.एस.एक्ट 2013 के प्रावधानों के अनुसार क्रियान्वित की प्रभावी समीक्षा हेतु जिला स्तरीय एवं उपखण्ड स्तरीय सतर्कता समितियों की त्रैमासिक बैठकें आयोजित कर अधिनियम एवं माननीय सर्वोच्च न्यायालय द्वारा याचिका संख्या 583/2003 में दिये गये निर्णय दिनांक 27.03.2014 की पूर्ण पालना की जानी आवश्यक है।

यह अत्यन्त खेदजनक एवं चिंताजनक स्थिति है कि अनेकशः निर्देशित करने के बावजूद निरंतर इस तरह की घटनाएँ घटित हो रही हैं जिनमें बहुत अमानवीय ढंग से कार्य करवाने के कारण मानव जीवन की क्षति हो रही है। जबकि माननीय सर्वोच्च न्यायालय द्वारा पारित निर्णय एवं अन्यथा विद्यमान प्रावधानों के अनुसार इस तरह की दुर्घटना अनपेक्षित है।

उक्त के अलावा यह भी उल्लेखनीय है कि सामाजिक न्याय एवं अधिकारिता मंत्रालय और आवासन एवं शहरी कार्य मंत्रालय भारत सरकार की संयुक्त पहल के तहत सफाई कर्मियों को गरिमा प्रदान करने और उन्हें सामाजिक और आर्थिक रूप से सशक्त बनाने तथा सीवरेज लाईन/सैण्टिक टैंकों की सफाई आधुनिक मशीनों के माध्यम से पूर्ण सुरक्षा उपकरणों के साथ किये और सफाई कर्मियों की शून्य मृत्यु हो इसके लिए 'राष्ट्रीय यंत्रीकृत स्वच्छता इकोसिस्टम तंत्र कार्य योजना' (National Action Plan for Mechanised Sanitation Ecosystem- NAMASTE) तैयार की गई है (जिसकी पालना जिला से

Signature valid
Digitally signed by Sanjit Sharma
Designation: Secretary To
Government
Date: 2023.07.20 18:24:06 IST
Reason: Approved

RajKaj Ref No. : 4308455

//True copy

प्राप्त पी.पी.टी. की प्रति संलग्न है)। साथ ही राष्ट्रीय सफाई कर्मचारी वित्त एवं विकास निगम नई दिल्ली द्वारा सीवरेज/सैप्टिक टैंको की सफाई कार्यों के लिए आवश्यक आधुनिक मशीनों के क्रय किये जाने हेतु ऋण उपलब्ध करवाने के लिए "स्वच्छता उद्यमी योजना" भी प्रारम्भ की गई है जिसकी विस्तृत जानकारी एवं प्रक्रियाओं के संबंध में वेबसाईट nskfdc.nic.in का अवलोकन फरमावें (संलग्न निर्देशिका)

अतः आपसे अपेक्षा की जाती है कि एम.एस.एक्ट 2013 एवं माननीय सर्वोच्च न्यायालय सिविल रिट 583/2003 में दिये गये निर्णय दिनांक 27.03.2014 के निर्देश/प्रावधानों की पूर्ण पालना तथा सीवरेज लाईन/सैप्टिक टैंकों की सफाई कार्य पूर्ण सुरक्षा उपकरणों के साथ ही किये जाने हेतु संबंधित नगरीय निकाय/ग्रामीण क्षेत्रों को निर्देशित करने का श्रम करावें तथा अधिनियम के प्रावधानों के अनुसार गठित जिला एवं उपखण्ड स्तरीय सतर्कता समितियों की नियमित अन्तराल में बैठके आयोजित कर अधिनियम एवं माननीय सर्वोच्च न्यायालय के निर्देशों की पालना सुनिश्चित करने का श्रम करावें।

संलग्न:-उपरोक्तानुसार।

(डॉ.समित शर्मा)

शासन सचिव

क्रमांक:एफ () एस्सीएसपी/स्वच्छकार/सान्याअवि/2023/ 2433-2516

जयपुर, दिनांक 21.7.2023

प्रतिलिपि निम्न को सूचनार्थ एवं आवश्यक कार्यवाही हेतु :-

1. वरिष्ठ उप सचिव, मुख्य सचिव, कार्यालय शासन सचिवालय जयपुर राज.।
2. निजी सचिव, अति.मुख्य सचिव, ग्रामीण विकास एवं पंचायतीराज विभाग शासन सचिवालय जयपुर को प्रेषित कर अनुरोध है कि ग्रामीण क्षेत्रों में एम.एस.एक्ट 2013 की पालना करवाया जाना सुनिश्चित करावें।
3. निजी सचिव, शासन सचिव, सान्याअवि, शासन सचिवालय जयपुर।
4. निजी सचिव, शासन सचिव, स्वायत्त शासन विभाग, शासन सचिवालय जयपुर को प्रेषित कर अनुरोध है कि आपके अधीनस्थ नगरीय निकायों को एम.एस.एक्ट 2013 के प्रावधानों की पालना हेतु निर्देशित करावें।
5. निजी सचिव, निदेशक एवं विशिष्ट शासन सचिव, सान्याअवि, जयपुर।
6. निजी सचिव, निदेशक स्वायत्त शासन विभाग, जयपुर को भेजकर लेख है कि आपके अधीनस्थ नगरीय निकायों को एम.एस.एक्ट 2013 के प्रावधानों की पालना हेतु निर्देशित करावें।
7. मुख्य कार्यकारी अधिकारी (ग्रा.वि.प्र.) जिला परिषद् समस्त राजस्थान को भेजकर लेख है कि ग्रामीण क्षेत्रों में एम.एस.एक्ट 2013 की पालना सुनिश्चित करावें।
8. निजी सचिव, निदेशक एवं विशिष्ट शासन सचिव, सान्याअवि, जयपुर।
9. संयुक्त/उप/सहायक निदेशक, सान्याअवि समस्त राजस्थान को भेजकर लेख है कि जिला कलक्टर की अध्यक्षता में गठित जिला स्तरीय /उपखण्ड अधिकारी की अध्यक्षता में गठित उपखण्ड स्तरीय सतर्कता समितियों की नियमित बैठके आयोजित कर एम.एस.एक्ट 2013 की पालना सुनिश्चित करावें।

//True copy//

शासन सचिव
Signature valid

Digitally signed by Samit Sharma
Designation: Secretary To
Government
Date: 2023.07.20 18:24:06 IST
Reason: Approved

True copy

सर्वोपरोक्त प्रमाणों पर विचार करके निम्नलिखित निर्णय किया गया है -
1. प्रमाणों को ध्यान से पढ़ा गया है।
2. प्रमाणों में कोई भी अस्पष्टता नहीं है।
3. प्रमाणों से स्पष्ट है कि...

दिनांक: 25.12.2003
[Signature]

प्रमाणों को ध्यान से पढ़ा गया है। प्रमाणों से स्पष्ट है कि...

निम्नलिखित प्रमाणों पर विचार करके निम्नलिखित निर्णय किया गया है -

1. प्रमाणों को ध्यान से पढ़ा गया है।
2. प्रमाणों में कोई भी अस्पष्टता नहीं है।

3. प्रमाणों से स्पष्ट है कि...

4. प्रमाणों को ध्यान से पढ़ा गया है।

5. प्रमाणों में कोई भी अस्पष्टता नहीं है।

6. प्रमाणों से स्पष्ट है कि...

7. प्रमाणों को ध्यान से पढ़ा गया है।

8. प्रमाणों में कोई भी अस्पष्टता नहीं है।

9. प्रमाणों से स्पष्ट है कि...

दिनांक: 25.12.2003
[Signature]

2-11-17

163

Dr. Manoj Singh
UP State Council

True copy

गठित समिति वर्तित अधिनियम के प्रावधानों के राज्य स्तर पर क्रियान्वयन समस्त विभाग के साथ समन्वय स्थापित कर अस्वच्छकಾರ्यों के आर्थिक एवं सामाजिक पुनर्वास को मॉनिटर करने पर अधिनियम की प्रभावी क्रियान्विति हेतु राज्य सरकार को सलाह देने से संबंधित कार्यों का निष्पादन करने की अधिनियम के प्रावधानों द्वारा राज्य सरकार द्वारा अस्वच्छकार्यों के आर्थिक पुनर्वास से जुड़े सामाजिक

- 14. निर्देशक, सामाजिक न्याय एवं अधिकारिता विभाग
- 13. अधिनियम की क्रियान्विति हेतु राज्य सरकार द्वारा आवश्यक समझे जाने वाले विभाग/एजेंसी के प्रतिनिधि
- 12. राज्य स्तरीय वृकर्स समिति के सदस्य
- महेश नगर, जयपुर।
- (iv) नीलम जबाहिया पूर्वी श्री शीमाप्रकाश जबाहिया, पटेल नगर, हुंदा की भौती, गौरी साकेल के पास, रामगज बाजार, जयपुर।
- (iii) श्रीमती चन्दा नकवाल पत्नी श्री भारत नकवाल, 258 खामगुड़ी, महिला संघ।
- (ii) श्री चन्द्रप्रकाश चौहान (टाईसन) पुत्र श्री रामचन्द्र चौहान, बी-6, वाल्मिकि बस्ती, गार्ड नं. 4, श्री इंग्लिश-331803, बीकानेर
- (i) श्री पुष्कराज देवी पुत्र श्री केशराम देवी, एडवांकेट मोमसर बास, पुरुष संघ।
- 11. स्वच्छकार्यों के कल्याणार्थ और उनके पुनर्वास से जुड़े सामाजिक कार्यकर्ताओं के प्रतिनिधि 26 (1) (आई)
- 10. राज्य सरकार द्वारा अधिसूचित एक माहानगर पालिका, जिना परिसर।
- 9. प्रमुख शासन सचिव, स्वायत्त शासन विभाग
- 8. प्रमुख शासन सचिव, पंचायतीराज विभाग
- 7. प्रमुख शासन सचिव, गृह विभाग
- 6. प्रमुख शासन सचिव, सामाजिक न्याय एवं अधिकारिता विभाग
- 5. पुलिस महानिदेशक
- श्री कैलाश बर्मा विधायक, बाराक, जयपुर, सदस्य राज्य विधानसभा
- श्री रामचंद्र विधायक, जग, झालावाड़, सदस्य राज्य विधानसभा
- 4. विधायक कोट से 26 (1) (ई)-
- 3. अध्यक्ष, राज्य सफाई कर्मचारी आयोग एवं अनुसूचित जाति आयोग
- 2. राष्ट्रीय सफाई कर्मचारी आयोग एवं अनुसूचित जाति आयोग के प्रतिनिधि
- 1. श्री, सामाजिक न्याय एवं अधिकारिता विभाग

गठित महानिरीक्षण राज्यपाल महोदय की आज्ञा से एतद्वारा किया जाता है:-
कमल सरकार द्वारा हुए दो गैराल कर्मियों के नियोजन का प्रतिवेदन और उनका पुनर्वास अधिनियम 2013 की धारा 26 (1) के तहत शहियों के अनुसूचित राज्य स्तरीय स्तरों की समिति का

कमांक एफ 6 (7) म.सू./अ.सू.-3/2015/
प्रशासनिक सुधार (अनुभाग-3) विभाग
राजस्थान सरकार
जयपुर, दिनांक 5-2-2015

15

क्रमांक एफ 6 (1) प्र.सु./अनु.-3/2015/

प्रतिलिपि निम्न को सूचनार्थ एवं आवश्यक कार्यवाही हेतु प्रेषित है:-

1. प्रमुख सचिव, महामहिम राज्यपाल महोदय, राजस्थान, जयपुर ।
2. प्रमुख सचिव, माननीय मुख्यमंत्री महोदय, राजस्थान, जयपुर ।
3. राष्ट्रीय, सफाई कर्मचारी आयोग, नई दिल्ली ।
4. सचिव, भारत सरकार, सामाजिक न्याय एवं अधिकारिता मंत्रालय, नई दिल्ली ।
5. विशिष्ट सहायक, माननीय मंत्री महोदय, गृह/वित्त/पंचायतीराज/स्वायत्त शासन /सामाजिक न्याय एवं अधिकारिता विभाग, राजस्थान, जयपुर ।
6. समस्त समिति सदस्य श्री/श्रीमती
7. मुख्य सचिव/अतिरिक्त मुख्य सचिव/प्रमुख शासन सचिव, गृह/वित्त/. पंचायतीराज/स्वायत्त शासन/सामाजिक न्याय एवं अधिकारिता विभाग, राजस्थान, जयपुर ।
8. महाप्रबन्धक, उत्तर पश्चिम, रेल्वे, राजस्थान, जयपुर ।
9. महानिदेशक पुलिस, राजस्थान, जयपुर ।
10. राष्ट्रीय, अनुसूचित जाति आयोग, नई दिल्ली ।
11. राज्य, अनुसूचित जाति आयोग, राजस्थान, जयपुर ।
12. राज्य सफाई कर्मचारी आयोग, राजस्थान, जयपुर ।
13. सम्बन्धित मुख्य कार्यकारी अधिकारी, महानगर पालिका/नगर परिषद/कन्टोनमेन्ट बोर्ड
14. राज्य स्तरीय बैंकर्स समिति
15. समस्त जिला कलक्टर,
16. समस्त पुलिस अधीक्षक
17. निदेशक, जनसम्पर्क विभाग, राजस्थान, जयपुर ।
18. निदेशक/आयुक्त, सामाजिक न्याय एवं अधिकारिता विभाग, राजस्थान, जयपुर ।
19. महाप्रबन्धक, अनु. जाति एवं जनजाति वित्त एवं विकास सहकारी निगम लि. जयपुर ।
20. गार्ड फाईल

अनुभाग अधिकारी

//True copy//

(347)

राजस्थान सरकार
प्रशासनिक सुधार (अनुगाग-3) विभाग

क्रमांक :- एफ 6(7)प्र.सु./अनु-3 /2015/

जयपुर,दिनांक 13.05.2016

आज्ञा

हाथ से मैला ढोने वाले कार्मिकों के नियोजन का प्रतिषेध और उनका पुनर्वास अधिनियम 2013 के नियम 24(1) में प्रदत्त शक्तियों के अनुसरण में राजस्थान राज्य के समस्त जिलों के लिए जिला स्तरीय सतर्कता समिति का गठन निम्नानुसार एतद् द्वारा किया जाता है-

1. जिला कलक्टर-अध्यक्ष,
2. जिले के अनुसूचित जाति के समस्त विधान सभा सदस्य- सदस्य, (जिले में अनुसूचित जाति के सदस्य न होने पर राज्य सरकार द्वारा मनोनित अधिकतम दो विधान सभा सदस्य)
3. जिला पुलिस अधीक्षक-सदस्य,
4. मुख्यकार्यकारी अधिकारी जि.प.-सदस्य,
5. जिला मुख्यालय पर स्थापित नगरीय निकाय का मुख्य कार्यकारी अधिकारी-सदस्य,
6. जिले में स्थित कन्टोनमेन्ट बोर्ड के कार्यकारी अधिकारी- सदस्य,
7. रेलवे की ओर से मनोनित प्रतिनिधि-सदस्य,
8. अस्वच्छकारों के कल्याणार्थ और उनके पुनर्वास के जुड़े संस्थाओं के अधिकतम चार समाजिक कार्यकर्ता जिसमें दो महिलाएं आवश्यक है। (जिला कलक्टर द्वारा मनोनित)-सदस्य,
9. जिले में वित्तीय एवं साख् से जुडा प्रतिनिधि (जिला कलक्टर द्वारा मनोनित)-सदस्य,
10. जिला कलक्टर की राय में अन्य जिला स्तरीय अधिकारी जो अधिनियम की क्रियान्विति में सहायक हो-सदस्य,
11. जिला समाज कल्याण अधिकारी-पदेन सदस्य सचिव।

गठित समिति वर्णित अधिनियम के प्रावधानों के क्रियान्वयन, समस्त विभागों के साथ समन्वय स्थापित कर अस्वच्छकारों के आर्थिक एवं सामाजिक पुनर्वास तथा अधिनियम के अन्तर्गत अपराध का पंजीयन, अनुसंधान एवं अभियोजन कार्य को मोनिटर करने के लिए प्रत्येक तिमाही में कम से कम एक बार बैठक आहूत कर जिला मजिस्ट्रेट को विहित कर्तव्यों के सम्बन्ध में सलाह देने से सम्बन्धित कार्यों का निष्पादन करेगी।

र. भा. प्र. सु.
131 57 2416
(रमेश चन्द्र भारद्वाज)
शासन उप सचिव

जयपुर,दिनांक

क्रमांक :- एफ 6(7)प्र.सु./अनु-3 /2015/

प्रतिलिपि:- सूचनार्थ एवं आवश्यक कार्यवाही हेतु प्रेषित है।

1. प्रमुख शासन सचिव महोदय सामाजिक न्याय एवं अधिकारिता विभाग शासन सचिवालय, जयपुर
2. शासन सचिव, पंचायतीराज/स्वायत्त शासन विभाग, जयपुर।

//True copy//

//True copy//

शासन उप सचिव
13/5/2011
2-मीमा

13. गाई पत्रावली।
12. महोपबन्धक, अ.ज.जाति जनजाति विल एंव विकास सहकारी निगम लिओ जयपुर।
11. निजी सहायक, प्रमुख शासन सचिव नगरीय विकास एवं स्वायत्त शासन विभाग, जयपुर।
10. निजी सहायक, प्रमुख शासन सचिव ग्रामीण विकास एवं पंचायती राज विभाग, जयपुर।
9. निजी सहायक, अतिरिक्त मुख्य सचिव प्रशासनिक सुधार विभाग, जयपुर।
8. निजी सहायक, माननीय मंत्री सामाजिक न्याय एवं अधिकारिता विभाग, जयपुर।
7. निदेशक, स्वायत्त शासन/विशेष योजना/संवना एवं जनसम्पर्क विभाग, जयपुर।
6. जिला स्तरीय समिति समस्त सदस्य।
5. समस्त जिला कलेक्टर-अध्यक्ष जिलास्तरीय समिति।
4. आयुक्त, सामाजिक न्याय एवं अधिकारिता, विभाग जयपुर।
3. सचिव, राजस्थान विधान सभा, सचिवालय जयपुर।

(3248)

//True copy//

राजस्थान सरकार
प्रशासनिक सुधार (अनुभाग-3) विभाग
6(7) प्र.सू./अनु-3/2015

सूचनाएं एवं आवश्यक कार्यवाही हेतु प्रेषित है।
राजस्थान नवोदय महादय सामाजिक न्याय एवं अधिकारिता विभाग शासन सचिवालय,
जयपुर

एक 6(7) प्र.सू./अनु-3/2015

जयपुर, दिनांक

राजस्थान नवोदय
(सूचना एवं संचार)
13/07/2015
रा.सू.प्र.सू.

राजस्थान नवोदय महादय सामाजिक न्याय एवं अधिकारिता विभाग शासन सचिवालय,
जयपुर

उपरोक्त स्तर पर स्थित अनुसूचित जाति के विकास से जुड़े विभाग का अधिकारी
किया जाये।

उपरोक्त अधिकारी की राय में अन्य उपरोक्त स्तरीय अधिकारी जो अधिनियम की
-सदस्य,

उपरोक्त अधिकांश द्वारा मनोनित उपरोक्त स्तर पर वित्तीय एवं साख से जुड़ा प्रतिनिधि
है।-सदस्य,

मनोनित संस्थाओं के अधिकतम दो सामाजिक कार्यकर्ता जिसमें एक महिलाएं आवश्यक
-सदस्य

उपरोक्त स्तर पर देवे की ओर से मनोनित प्रतिनिधि-सदस्य,
उपरोक्त में स्थित कन्वेंशन बोर्ड के कार्यकारी अधिकारी-सदस्य,

अधिकारी-सदस्य,
उपरोक्त स्तर पर स्थापित नगरीय निकाय का मुख्य कार्यकारी अधिकारी/अधीक्षक

मनोनित दो मान्य पदायता के अध्यक्ष)-सदस्य,
स्तर पर पदायत समिति स्थापित नहीं होने की दशा में उपरोक्त अधिकारी द्वारा

उपरोक्त स्तर पर स्थापित पदायत समिति के अध्यक्ष एवं विकास अधिकारी (उपरोक्त
-सदस्य

द्वारा प्रतिष्ठित उप-अधीक्षक-सदस्य,
उपरोक्त अधिकारी-अध्यक्ष

उपरोक्त स्तरीय समकाली समिति का गठन निम्नानुसार एतद् द्वारा किया जाता है-
विभाग 24(1) में प्रदत्त शक्तियों के अनुसरण में राजस्थान राज्य के समस्त उपरोक्तों

द्वारा से मिला जाने वाले कार्मिकों के नियोजन का प्रतिबंध और उनका पुनर्वास अधिनियम

आज्ञा

जयपुर, दिनांक 13-05-2018

6(7) प्र.सू./अनु-3/2015

राजस्थान सरकार
प्रशासनिक सुधार (अनुभाग-3) विभाग

349

- (250)
3. आयुक्त, सामाजिक न्याय एवं अधिकारिता, विभाग जयपुर।
 4. समस्त जिला कलेक्टर राजस्थान।
 5. समस्त उपखण्ड अधिकारी अध्यक्ष उपखण्ड स्तरीय समिति।
 6. उपखण्ड स्तरीय समिति-समस्त सदस्य।
 7. निदेशक, स्वायत्त शासन / विशेष योग्यजन / सूचना एवं जनसम्पर्क विभाग, जयपुर।
 8. निजी सहायक, माननीय मंत्री सामाजिक न्याय एवं अधिकारिता विभाग, जयपुर।
 9. निजी सहायक, अतिरिक्त मुख्य सचिव प्रशासनिक सुधार विभाग, जयपुर।
 10. निजी सहायक, प्रमुख शासन सचिव ग्रामिण विकास एवं पंचायती राज विभाग, जयपुर।
 11. निजी सहायक, प्रमुख शासन सचिव नगरीय विकास एवं स्वायत्त शासन विभाग, जयपुर।
 12. महाप्रबन्धक, अनु.जाति जनजाति वित्त एवं विकास सहकारी निगम लि० जयपुर।
 13. गार्ड फत्रावली।

र. म. पां. दे
13/5/2018
शासन उप सचिव

//True copy//



Government of Sikkim
Social welfare Department
Lumsey, 5th Mile, Tadong
Gangtok

No: 127(1)/SWD/SJD/2023

Dated 24/12/2023

To

Shri S.K. Srivastwa, Deputy Secretary,
Ministry of Social Justice and Empowerment,
Department of Social Justice and Empowerment,
B-2, Ground floor, Pt. Deendayal Antyodaya Bhawan,
CGO Complex, New Delhi-110003.

Subject: - Civil Writ Petition (PIL) No. 324 of 2020 in the matter of Dr. Balaram singh vs union of India and orders pending before Supreme Court of India.

Sir,

In continuation of this office letter No. 127/SWD/SJD/2023 dated 01/07/2023 and reference to your letter No. U-12012/01/2023(Plan) dated 15TH December, 2023 and the Video Conference held on 15th December, 2023 on the above cited subject, i am directed to forward herewith the Action Taken Report on the observation of the Supreme Court of India for favour of your information and necessary action, please.

Thanking you,

Yours faithfully,

Enclosed as above.

(Kishore Pradhan)

Additional Secretary (SID)
Social Welfare Department

//True copy//

State name- Sikkim		Annexure V		
Sl No	Name of Institutions	Date of constitution or designating	Name of Commission/Agency designated to act as Commission	If not, reasons thereof
1	Constitution of State Safai Karamcharis Commission/Designating an Agency to work as State Safai Karamcharis Commission (Section 32 of MS Act, 2013)	State Government has designated the State Commission for the Backward Classes (SCBC) to perform the functions specified in sub-section (1) of Section 31 of the Prohibition of Employment as Manual Scavengers and their Rehabilitation Act, 2013 vide Notification No. 77/Home/2023 dated 22/12/2023.	State Commission for the Backward Classes (SCBC)	
2	State Monitoring Committee (Section 26 of MS Act, 2013)	Constituted vide Notification No. 98/Home/2014 dated 08/11/2014 (copy enclosed)		
3	District Vigilance Committee (Section 24 (2) of MS Act 2013)	Constituted vide Notification No.GOS/UD&HD/6(145)06/19 dated 27/11/2014 (opy enclosed)		
4	Sub-Division Vigilance Committee (Section 24 (3) of MS Act 2013)	-do-		
5	State Level Survey Committee (Rule 2-j of MS Rules 2013)			
6	District level survey committee (Rule-2-c of MS Rules 2013)	Rural & Urban Survey Committee constituted vide Notification No- 123/SWD/SJD/2023-24 dated 29/06/2023 (copy enclosed)		
7	Nomination of the Secretary, Social Welfare Department as Nodal Officer to deal with the cases of Safaikaramcharis	Mrs. Sarika Pradhan, SCS Secretary, Social Welfare Department has been designated as Nodal officer vide Office Order No. 553/SWD/ADM/2023 dated 22/12/2023.(contact no. 9434756998)		

//True copy//



GOVERNMENT OF SIKKIM
HOME DEPARTMENT
TASHILING SECRETARIAT
GANGTOK

No: 77 /Home/2023

Dated: 22/12/2023

NOTIFICATION

In exercise of the powers conferred by section 32 (1) of The Prohibition of Employment as Manual Scavengers and their Rehabilitation Act, 2013, the Government is hereby pleased to designate the State Commission for the Backward Classes (SCBC) to perform the functions specified in sub-section (1) of section 31 of the said Act within the State.

Sd/-

(V.B. Pathak) IAS

Chief Secretary

Government of Sikkim

File No. GOS/SWD/ADM/23-24/388/III

Copy for information to:

1. The Secretary to the Hon'ble Governor, Raj Bhavan;
2. The Secretary to the Hon'ble Chief Minister, CMO;
3. The Chairperson, State Commission for the Backward Classes (SCBC), Government of Sikkim, Gangtok;
4. The Director General of Police, Sikkim Police Headquarters, Gangtok;
5. The Secretary, Social Welfare Department, Govt. of Sikkim, Gangtok;
6. The District Collectors, Gangtok Gyalshing, Mangan, Namchi, Pakyong and Soreng District;
7. The Additional Director-cum-Staff Officer to the Chief Secretary, Gangtok;
8. PS to Additional Chief Secretary, Home Department, Government of Sikkim;
9. Sr. PA to Secretary, Home Department, Government of Sikkim, Gangtok;
10. Gazette Section, Home Department - for publication in the official Gazette;
11. Programmer-IT, Home Department - for uploading on official website;
12. File & Guard File.



Joint Secretary-I (Confdl.)
Home Department

//True copy//

G20



GOVERNMENT OF SIKKIM
SOCIAL WELFARE DEPARTMENT
TADONG, GANGTOK-737102

No.: 553 /SWD/ADM/2023

Dated: 29/12/2023

OFFICE ORDER

In compliance with the judgement of Hon'ble Supreme Court of India dated 20.10.2023 for the Writ Petition (Civil) No. 324/2020 Dr. Balaram v/s Union of India and Ors before Supreme Court of India, Secretary, Social Welfare Department is hereby nominated as the Nodal Officer for all the matters dealing with Safaikarmacharis in the State of Sikkim.

By Order.

Sd/-
(Kishore Pradhan) SCS
Additional Secretary to the Government
Social Justice Division

Memo No. 2514 /SWD/ADM

Dated: 29/12/2023

2516

Copy to:

1. Secretary, Social Welfare Department
2. Deputy Secretary to Government of India, Ministry of Social Justice & Empowerment, Department of Social Justice & Empowerment,
3. Staff Officer to Chief Secretary, Government of Sikkim,
4. File &
5. Guard File.

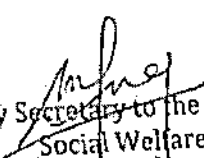
Deputy Secretary to the Government
Social Welfare Department
GOS/SWD/ADM/21-22/33/III

TRUE COPY!!!

Annexure - IV - J

GOVERNMENT OF TRIPURA
DEPARTMENT FOR WELFARE OF SCHEDULED CASTES
(P.N. Complex, Gurkhabasti, Agartala)
(Email: directorscw@gmail.com, Contact No: No. 0381-232 -3363)

No.F.S-21S (P-V)/SCW/PLG/2017 (II)/17349-50 Dated, Agartala, the 27 June, 2023.

✓ To
The Deputy Secretary (S.K. Srivastwa)
Government of India,
Department of Social Justice & Empowerment,
B-2, Ground Floor, Pt. Deendayal Antyodaya Bhawan,
CGO Complex, New Delhi-110003.

Subject:- Civil Writ Petition (PIL) No. 324 of 2020 in the matter of Dr. Balram Singh Vs Union of India and Others pending Before Supreme Court of India-regarding.

Sir,

Kindly refer to your letter No.U-12012/1/2023 (Plan) dated, 15th December, 2023 on the subject cited above, i am directed to send herewith requisite Information / Action Taken Report (ATR) of the Hon'ble Supreme Court's Order dated 20.10.2023 on the Civil Writ Petition (PIL) No. 324 of 2020 in the matter of Dr. Balram Singh Vs Union of India and Others at Annexure-I.

This is for your kind information and doing the needful, please.

Yours faithfully,

Encl : As stated.

(Asin Saha) 28/12/23
Addl. Secretary to the
Government of Tripura.

Copy to:-

1. The P.S. to the Principal Secretary, SC Welfare Department, Government of Tripura for kind information.

TRUE COPY //

28/12/23
Addl. Secretary to the
Government of Tripura.

173

Handwritten scribbles in the top right corner.

Handwritten scribbles in the bottom left corner.

Small handwritten mark in the bottom right area.

Name of State :- Tripura

Para wise Action Taken Report (ATR) of the Hon'ble Supreme Court order dated 20.10.2023 of Writ Petition (Civil) No.324 of 2020 filed by Dr. Balaram Singh Vs. Union of India & Ors.

Sl. No.	Points	Reply	Remarks
1	MS Act, 2023; MS Rules 2023 and guidelines framed by the Union are embodied in States / UTs guidelines and directions are applicable to all municipalities and local bodies [Para 96 (2)]	<ul style="list-style-type: none"> The Prohibition of Employment as Manual Scavengers and their Rehabilitation Act. and Rules, 2013 are following to all Municipalities and Local Bodies in the State of Tripura. The State Government already declared the entire State Manual Scavengers free vide issued Notification No.F.16 (4)-LSG/89 dated, 30th April, 1991. (copy enclosed) 	
2	Full rehabilitation (including employment to the next of kin, education to the wards, and skill training) of sewer workers, and those who are die [Para 96 (3)]	2 (two) workers were died due to occurrence an accident in the course of their employment in the worksite at Indranagar, Agartala, West Tripura in the year 2016. Compensation @ Rs.10.00 lakh were paid to the next kin of the victims as per Hon'ble Supreme Court Verdict on 27/03/2014 of WP (C) No.583 of 2003.	
3	Payment of compensation with increased amount i.e. Rs.30.00 lakhs for sewer deaths. In the event, dependents of any victim have not been paid such amount, the above amount shall be payable to them, hereafter as compensation [Para 96 (4)]	<ul style="list-style-type: none"> Compensation for sewer death is increased (given that the previous amount fixed i.e. 10.00 lakh) was made applicable and the current equivalent of that amount is Rs. 30.00 lakh. Payment of compensation of Rs.20.00 lakhs, in the case of sewer victims suffering disabilities, depending upon the severity of disabilities. Minimum compensation shall not be less than Rs. 10.00 lakhs. 	
4	Payment of compensation of Rs.20.00 lakhs, in the case of sewer victims suffering disabilities, depending upon the severity of disabilities. Minimum compensation shall not be less than Rs. 10.00 lakhs. [Para 96 (5)]	In this regard, the Govt. of Tripura issued Notification vide No. F.5-415(P-V)/SCW/PLG/ 2017(11)/15464-664 dated 15/12/2023. (copy enclosed):	
5	Devise suitable mechanism to ensure accountability, especially wherever sewer deaths occur in the course of contractual or "outsourced work. [Para 96 (6)]	Suitable mechanism has already in place in all ULBs in the State.	

True copy//

Sl. No.	Points	Reply	Remarks
6	Set up scholarships to ensure that the dependents of sewer victims, (who have died, or might have suffered disabilities) are given meaningful education [Para 96 (10)]	Matter will be taken up soon to the appropriate authority.	
7	Ensure establishment of State Commission for Safai Karamcharis and all Committees mentioned in MS Act, 2013 and MS Rules 2013 including State Level Monitoring Committee, State Level Survey Committee, District Vigilance Committee and District Level Survey Committee by 30.11.2023. [Para 96 (12)]	<ul style="list-style-type: none"> • The Government of Tripura had declared that Tripura is free of Scavengers vide Notification No.F.16 (4)-LSG/89 dated, 30th April, 1991. (copy enclosed) • However, Government of Tripura had reconstituted the State Level Monitoring Committee as per sub section (1) of section 26 for monitoring of implementation of the Prohibition of Employment as Manual Scavengers and their Rehabilitation Act, 2013 vide Notification No.F.5-415/ PLG/P-V/ 2017/Shadow/A/5583-681 dated, 17-07-2023. (Copy enclosed) • Constituted District Level Vigilance Committee and Sub-Division Level Vigilance Committee as per section-24 of chapter-VII for monitoring of implementation of the Prohibition of Employment as Manual Scavengers and their Rehabilitation Act, 2013. Vide Notification No.F.4-234/SCW/ STAT/2018/ 23012-112 & No. F.4-234/SCW/STAT/2018 /23113-213 dated, 01-03-2019. (Copy enclosed) • The Government of Tripura has constituted the Tripura State Commission for Safai Karamcharis as per sub section (1) of section 32 for implementation of the Prohibition of Employment as Manual Scavengers and their Rehabilitation Act, 2013. Vide Notification No.F.4-234/SCW/ STAT/ 1018, /1666-78 dated-04.05.2021. (Copy enclosed). • State and District Level Survey Committee constitution under process and it will be completed very soon. 	//True copy// 

//True copy//

175



NO.F.16(4)-LSG/89
GOVERNMENT OF TRIPURA
LOCAL SELF GOVERNMENT DEPARTMENT

Dated, Agartala, the 30th April, 91.

N O T I F I C A T I O N

It is for general information of all concerned that the carrying of night soil by head and manual scavenging have been fully abolished in Tripura. Thus Tripura is free of scavengers.

By Order,

(OM PRAKASH) 29/4/91
SECRETARY TO THE
GOVERNMENT OF TRIPURA

To

All Concerned
All Commissioner/Secretaries,
All Head of the Departments.

Copy to: The Manager, Tripura Government Press, Agartala, with request to publish the above notification in an Extraordinary issue of Tripura Gazette. 20 copies of the Gazette notification may kindly be sent to this Department in due course.

Copy also forwarded for favour of kind information to:

1. SSecretary to the Governor of Tripura, Agartala.
2. Special Assistant cum Joint Secretary to Chief Minister, Tripura.
3. Special Assistant cum Joint Secretary/Pps/Ps/Aps to Minister, _____
4. Pps/Ps/Aps/ to Minister of State _____
5. Special Assistant cum Joint Secretary to Chief Secretary, Tripura.
6. The Joint Secretary, Ministry of Welfare, Govt. of India, Shastri Bhavan, New Delhi.

(OM PRAKASH) 29/4/91
SECRETARY TO THE
GOVERNMENT OF TRIPURA.

True copy

F.No.5-415/PLG/P-V/2017/Shadow/A 5583-681
GOVERNMENT OF TRIPURA
DEPARTMENT FOR WELFARE OF SCs
TRIPURA :: AGARTALA.

Dated, 17/07/2023.

NOTIFICATION

The Governor is pleased to re-constitute the State Level Monitoring Committee for implementation of the Prohibition of Employment as Manual Scavenger and their Rehabilitation Act, 2013 as follows:-

1. The Hon'ble Minister for Welfare of Scheduled Castes, Govt. of Tripura : **Chairperson.**
2. The Principal Secretary / Secretary to the State Government, Department for Welfare of Scheduled Castes : **Member-Secretary.**
3. Sri Jitendra Majumder, Member of the Tripura Legislative Assembly : **Member**
4. Smt. Mina Rani Sarkar, Member of the Tripura Legislative Assembly : **Member.**
5. The Director General of Police : **Member.**
6. The Secretary, Government of Tripura, Home Department : **Member.**
7. The Secretary, Government of Tripura, P.R. Department : **Member.**
8. The Secretary, Urban Local Bodies : **Member.**
9. The Municipal Commissioner, Agartala Municipal Corporation : **Member.**
10. The Regional Director, Census Operation : **Member.**
11. The Station Manager, NF Railway, Agartala : **Member.**
12. The Convener, State Level Bankers Committee : **Member.**
13. Sri Tutan Das, Social Worker : **Member.**
14. Sri Dilip Das, Ex-MLA : **Member.**
15. Sri Krishnadhan Das, Ex-MLA : **Member.**
16. Sri Tapas Das, Advocate : **Member.**

The State Level Committee shall take effective measures for implementation of the "Prohibition of Employment as Manual Scavengers and their Rehabilitation Act-2013 (MS Act, 2013)" in the State. In order to effective implementation of the same issue to be considered in time for complete elimination of the inhuman practice of Manual Scavenging.

This will take immediate effect.

True copy
177

By order of the Governor
[Signature]
Under Secretary to the
Government of Tripura.

To

1. The Hon'ble Minister, Department for Welfare of Scheduled Castes, Govt. of Tripura for kind information.
2. The Prineipal Secretary / Secretary to the State Government, Department for Welfare of Scheduled Castes, Government of Trlpura for kind information.
3. Sri Jitendra Majumder, Member of the Tripura Legislative Assembly for kind information.
4. Smt. Mina Rani Sarkar, Member of the Tripura Legislative Assembly for kind information.
5. The Direetor General of Police, Tripura for kind information.
6. The Secretary, Home Department, Government of Tripura for kind information.
7. The Seeretary, P.R Department, Government of Tripura for kind information.
8. The Seeretary, Urban Loeal Bodies for kind information.
9. The Municipal Commissioner, Agartala Municipal Corporation for kind information.
10. The Regional Director, Census Operation, Tripura for kind iuformation.
11. The Station Manager, NF Railway, Agartala for kind information.
12. The Convener, State Level Bankers Committee for kind information.
13. Sri Tutan Das, Social Worker for kind information.
14. Sri Dilip Das, Ex-MLA for kind information.
15. Sri Krishnadhan Das, Ex-MLA for kind information.
16. Sri Tapas Das, Advocate for kind information.

Copy to:-

1. The Secretary to the Chief Minister, Govt. of Tripura for kind information of the Hon'ble Chief Minister.
2. The Private Secretary to the Minister for Welfare of Sch. Castes, Govt. of Tripura for kind information of the Hon'ble Minister, SCW.
3. The P.S. / P.A to the Minister _____ Govt. of Tripura for kind information of the Hon'ble Minister.
4. The PPS to the Chief Secretary, Govt. of Tripura for kind information of the Chief Secretary.
5. All Prineipal Secretaries / Commissioners / Secretaries to the Govt. of Tripura.
6. All Head of Department, _____ Govt. of ,Tripura for kind information and necessary action.
7. The District Magistrate & Coliector, West / Sepahijala / Gomati / Sonth / Khowai / Dhalai / Unakoti and North Tripura District for kind information.
8. The District Welfare Officer, West / Sepahijala / Gomati / South / Khowal / Dhalai / Unakoti and North Tripura District for kind information

178

17/11/2011
178

9. The Sub-Divisional Magistrate, Sadar / Mohanpur / Jirania / Bishalgarh / Sonamura / Jampuijala / Udaipur / Amarapur / Karbook / Belonia / Santirbazar / Sabroom / Khowai / Teliamura / Ambassa / Kamaipur / Gandacherra / Kanchanpur / Kailashahar / Kumarghat / Dharmanagar / Panlsagar and Longthorai Valley Sub-Division for information and necessary action.
10. The Chief Executive Officer / Executive Officer _____ AMC/MC/NP for information and necessary action.
11. The Block Development Officer, _____ Block for information and necessary action.
12. Ail Member of the SC Welfare Sub-Committee _____ AMC/MC/NP/ under _____ Block for information and necessary action.
13. The Manager, Tripura Government Press, Agartala for publication in the next issue of Tripura Gazette.
14. Guard File.

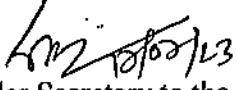
Under Secretary to the
Government of Tripura.

//True copy//
✓

GOVERNMENT OF TRIPURA
DEPARTMENT FOR WELFARE OF SCHEDULED CASTES

P.N. Complex, Gurkhabasti, Agartala

Email-directorsew@gmail.com

(Phone No. 0381-232 -3363)

No.F.5-415(P-V)/SCW/PLG/2017(II)/ 15464-664

Dated, the 15/12/2023.

NOTIFICATION

The Government of Tripura issued notification vide no.F.16 (4)-LSG/89 dated 30.04.1991 prohibiting carrying of night soil by head and thus manual scavenging had been fully abolished in Tripura. Thus Tripura is free of Manual Scavenging.

Now, it is for general information that the Hon'ble Supreme Court of India in Writ Petition (Civil) No. (S). 324 Of 2020 filed by Dr. Balaram Singh Vs. Union of India & Ors. Judgment dated 20th October, 2023 directed the Union and the States to ensure that the compensation for sewer deaths is increased (given that the previous amount fixed, i.e., Rs.10 lakh was made applicable from 1993). The current equivalent of that amount is Rs.30 lakh. This shall be amount to be paid, by the concerned agency, i.e, the Union, the Union Territory or the State as the case may be. In other words, compensation for sewer deaths shall be Rs. 30 lakh. In the event, dependents of any victim have not been paid such amount, the above amount shall be payable to them. Furthermore, this shall be the amount to be hereafter paid, as compensation.

Likewise, in the case of sewer victims suffering disabilities, depending upon the severity of disabilities, compensation shall be disbursed. However, the minimum compensation shall not be less than Rs. 10 lakh. If the disability is permanent, and renders the victim economically helpless, the compensation shall not be less than Rs.20 lakh.

(Asim Saha) 15/12/2023

Addl. Secretary to the
Government of Tripura.

Copy to:-

1. The Principal Secretary to the Chief Minister of Tripura for kind information of the Hon'ble Chief Minister.
2. The Private Secretary to the Minister for Welfare of Sch. Castes for information of the Hon'ble Minister.
3. The PS/PA to the Hon'ble Minister, _____ for information of the Hon'ble Minister.
4. The P.S. to the Chief Secretary, Govt. of Tripura for information of the Chief Secretary.
5. All Principal Secretaries/Commissioner/Secretaries, Govt. of Tripura _____ for kind information.
6. All Head of Department, Govt. of Tripura _____ for information.
7. The District Magistrate & Collector, North/Unakoti/Dhalai/Khowai/West/Sepahijala/Gomati and South Tripura District for kind information.
8. The District Welfare Officer, North/Unakoti/Dhalai/Khowai/West/Sepahijala/Gomati and South Tripura District for information.
9. The Sub-Divisional Magistrate, Dharmanagar/Panisagar/Kanchanpur/Kumarghat/Kailashahar/ Longtharai Valley/Ambassa/Kamalpur/Gandacharra/Teliamura/Khowai/Jirania/Sadar/Mohanpur/Bishalgarh/Jampuijala /Sonamnra/Udaipur/Amarpur/Karbook/Belonia/Santirbazar and Sabroom Sub-Division for information.
10. The Sub-Divisional Welfare Officer, Dharmanagar/Panisagar/Kanchanpur/Kumarghat/ Kailashahar / Longtharai Valley/ Ambassa/ Kamalpur/Gandacharra/Teliamura/Khowai /Jirania/Sadar/ Mohanpur/ Bishalgarh/Jampuijala/Sonamnra/Udaipur/Amarpur/Karbook/ Belonia/Santirbazar and Sabroom Sub-Division for information.
11. The Chief Executive Officer/ Executive Officer _____ AMC/MC/NP for information.
12. The Block Development Officer, _____ for information.
13. All Member of the SC Welfare Sub-Committee _____ AMC/MC/NP / under _____ Block for information.
14. The Manager Tripura Government Press, Agartala for publication in the next issue of Tripura Gazette.

189
15/12/2023
COPY//

Addl. Secretary to the
Government of Tripura.

No. F. 4-234/SCW/STAT/2018/ 23012-112
 GOVERNMENT OF TRIPURA
 DEPARTMENT FOR WELFARE OF SCs
 TRIPURA :: AGARTALA

Date, 1/13/2019.

NOTIFICATION

The Governor is pleased to constitute the District Level Vigilance Committee as per section-24, Chapter-VII of the Prohibition of Employment as Manual Scavengers and their Rehabilitation Act, 2013.

The District Vigilance Committee of each District consisting of the Chairperson, Member and Member-Secretary are as follows:-

1. West Tripura District
Agartala

Sl. No.	Designation	Status in the Committee
1	District Magistrate & Collector, Ex Officio)	Chairperson.
2	All MLAs belonging to Scheduled Castes.	Member
3	Superintendent of Police, Ex Officio.	Member
4	Secretary, Zilaparishad.	Member
5	Municipal Commissioner/C.E.O/E.O/Municipal Corporation/ Municipal Council /Nagar Panchayat (District Head Quarter)	Member
6	4(Four) Social Workers belonging to organizational work for the prohibition of Manual Scavenging out which 2(two) shall be women (to be nominated by DM & Collector)	Member.
7	Representative from Financial Credit Institution in the District (to be nominated by DM & Collector)	Member.
8	1(one) person to represent the Financial and Credit Institutions in the District (to be nominated by the District Magistrate).	Member
9	District Welfare Officer,	Member-Secretary.

2. North Tripura District
Dharmanagar

Sl. No.	Designation	Status in the Committee
1	District Magistrate & Collector, Ex Officio)	Chairperson.
2	All MLAs belonging to Scheduled Castes.	Member
3	Superintendent of Police, Ex Officio.	Member
4	Secretary, Zilaparishad.	Member
5	Municipal Commissioner/C.E.O/E.O/Municipal Corporation/ Municipal Council /Nagar Panchayat (District Head Quarter)	Member
6	4(Four) Social Workers belonging to organizational work for the prohibition of Manual Scavenging out which 2(two) shall be women (to be nominated by DM & Collector)	Member.
7	Representative from Financial Credit Institution in the District (to be nominated by DM & Collector)	Member.
8	1(one) person to represent the Financial and Credit Institutions in the District (to be nominated by the District Magistrate).	Member
9	District Welfare Officer,	Member-Secretary

3. South Tripura District.
Belonia

Sl. No.	Designation	Status in the Committee
1	District Magistrate & Collector, Ex Officio)	Chairperson.
2	All MLAs belonging to Scheduled Castes.	Member
3	Superintendent of Police, Ex Officio.	Member
4	Secretary, Zilaparishad.	Member
5	Municipal Commissioner/C.E.O/E.O/Municipal Corporation/ Municipal Council /Nagar Panchayat (District Head Quarter)	Member
6	4(Four) Social Workers belonging to organizational work for the prohibition of Manual Scavenging out which 2(two) shall be women (to be nominated by DM & Collector)	Member.
7	Representative from Financial Credit Institution in the District (to be nominated by DM & Collector)	Member.
8	1(one) person to represent the Financial and Credit Institutions in the District (to be nominated by the District Magistrate).	Member
9	District Welfare Officer,	Member-Secretary.

4. Dhalai District, Tripura
Ambassa

Sl. No.	Designation	Status in the Committee
1	District Magistrate & Collector, Ex Officio)	Chairperson.
2	All MLAs belonging to Scheduled Castes.	Member
3	Superintendent of Police, Ex Officio.	Member
4	Secretary, Zilaparishad.	Member
5	Municipal Commissioner/C.E.O/E.O/Municipal Corporation/ Municipal Council /Nagar Panchayat (District Head Quarter)	Member
6	4(Four) Social Workers belonging to organizational work for the prohibition of Manual Scavenging out which 2(two) shall be women (to be nominated by DM & Collector)	Member.
7	Representative from Financial Credit Institution in the District (to be nominated by DM & Collector)	Member.
8	1(one) person to represent the Financial and Credit Institutions in the District (to be nominated by the District Magistrate).	Member
9	District Welfare Officer,	Member-Secretary.

//True copy//

2
1982

**5. Unakoti District Tripura
Kailashahar**

Sl. No.	Designation	Status in the Committee
1	District Magistrate & Collector, Ex Officio)	Chairperson.
2	All MLAs belonging to Scheduled Castes.	Member
3	Superintendent of Police; Ex Officio.	Member
4	Secretary, Zilaparishad.	Member
5	Municipal Commissioner/C.E.O/E.O/Municipal Corporation/ Municipal Council /Nagar Panchayat (District Head Quarter)	Member
6	4(Four) Social Workers belonging to organizational work for the prohibition of Manual Scavenging out which 2(two) shall be women (to be nominated by DM & Collector)	Member.
7	Representative from Financial Credit Institution in the District (to be nominated by DM & Collector)	Member.
8	1(one) person to represent the Financial and Credit Institutions in the District (to be nominated by the District Magistrate).	Member
9	District Welfare Officer,	Member-Secretary.

**6. Khowai District Tripura.
Khowai**

Sl. No.	Designation	Status in the Committee
1	District Magistrate & Collector, Ex Officio)	Chairperson.
2	All MLAs belonging to Scheduled Castes.	Member
3	Superintendent of Police, Ex Officio.	Member
4	Secretary, Zilaparishad.	Member
5	Municipal Commissioner/C.E.O/E.O/Municipal Corporation/ Municipal Council /Nagar Panchayat (District Head Quarter)	Member
6	4(Four) Social Workers belonging to organizational work for the prohibition of Manual Scavenging out which 2(two) shall be women (to be nominated by DM & Collector)	Member.
7	Representative from Financial Credit Institution in the District (to be nominated by DM & Collector)	Member.
8	1(one) person to represent the Financial and Credit Institutions in the District (to be nominated by the District Magistrate).	Member
9	District Welfare Officer,	Member-Secretary.

//True copy//

**7. Sepahijala District, Tripura
Bishramganj**

Sl. No.	Designation	Status in the Committee
1	District Magistrate & Collector, Ex Officio)	Chairperson.
2	All MLAs belonging to Scheduled Castes.	Member
3	Superintendent of Police, Ex Officio.	Member
4	Secretary, Zilaparishad.	Member
5	Municipal Commissioner/C.E.O/E.O/Municipal Corporation/ Municipal Council /Nagar Panchayat (District Head Quarter)	Member
6	4(Four) Social Workers belonging to organizational work for the prohibition of Manual Seavenging out which 2(two) shall be women (to be nominated by DM & Collector)	Member.
7	Representative from Financial Credit Institution in the District (to be nominated by DM & Collector)	Member.
8	1(one) person to represent the Financial and Credit Institutions in the District (to be nominated by the District Magistrate).	Member
9	District Welfare Officer,	Member-Secretary.

**8. Gomati District, Tripura
Udaipur**

Sl. No.	Designation	Status in the Committee
1	District Magistrate & Collector, Ex Officio)	Chairperson.
2	All MLAs belonging to Scheduled Castes.	Member
3	Superintendent of Police, Ex Officio.	Member
4	Secretary, Zilaparishad.	Member
5	Municipal Commissioner/C.E.O/E.O/Municipal Corporation/ Municipal Council /Nagar Panchayat (District Head Quarter)	Member
6	4(Four) Social Workers belonging to organizational work for the prohibition of Manual Seavenging out which 2(two) shall be women (to be nominated by DM & Collector)	Member.
7	Representative from Financial Credit Institution in the District (to be nominated by DM & Collector)	Member.
8	1(one) person to represent the Financial and Credit Institutions in the District (to be nominated by the District Magistrate).	Member
9	District Welfare Officer,	Member-Secretary.

District Magistrate has a significant role to play in the implementation of the MS Act-2013.

Functions of Vigilance Committee shall be-

- (a) to advise the District Magistrate or, as the case may be, the Sub-Divisional Magistrate, on the action which needs to be taken, to ensure that the provisions of this Act, or of any rule made thereunder are properly implemented;
- (b) to oversee the economic and social rehabilitation of Manual Scavengers;
- (c) to co-ordinate the functions of all concerned agencies with a view to channelise adequate credit for the rehabilitation of Manual Scavenger;

184 • //True copy//

(d) to monitor the registration of offences under this Act and their investigation and prosecution.

This will take immediate effect.

(Ratan Biswas)
Addl. Secretary to the
Government of Tripura.

Copy to: -

1. The Principal Secretary to the Chief Minister for information of the Hon'ble Chief Minister.
2. The Private Secretary to the Minister for Welfare of Sch. Castes for information of the Hon'ble Minister.
3. The P.S/P.A. to the Minister _____ or information of the Hon'ble Minister.
4. The Hon'ble MLA, Tripura.....for information.
5. The P.S to the Chief Secretary for information of the Chief Secretary.
6. The Secretary, National Commission for Safai Karamcharis, Ministry of Social Justice & Empowerment, Govt. of India for information.
7. The Addl. Secretary, Ministry of Social Justice & Empowerment, Govt. of India for information.
8. All Principal Secretaries / Commissioner / Secretaries to the Govt. of Tripura.
9. All Head of Dept. Govt. of Tripura _____ for information and necessary action.
10. The District Magistrate & Collector, North/ Unakoti/ Dhalai/ Khowai/ West/ Sepahijal/ Gomati and South Tripura District.
11. The District Welfare Officer, North/ Unakoti/ Dhalai/ Khowai/ West/ Sepahijala/ Gomati and South Tripura.
12. The Secretary, _____ Zila Parishad for information.
13. The Sub-Divisional Magistrate, Dharmanagar/ Panisagar/ Kaichanpur/ Kumarghat/ Kailashahar/ Longthorai valley / Ambassa/ Kamalpur/ Gandachara/ Teliamura/ Khowai/ Jirania/ Sadar / Mohanpur/ Bishalgarh/ Jampuijala/ Sonamura/ Udaipur/ Amarpur/ Karbook/ Belonia/ Santirbazar/ Sabroom Sub-Division for information and necessary action.
14. The Chief Executive Officer/Executive Officer _____ AMC/MC/NP for information and necessary action.
15. The Block Development Officer _____ Block for information and Necessary action.
16. All Members of the SC Welfare Sub-Committee _____ AMC / M / NP / under _____-Block for information and necessary action.
17. The Manager, Tripura Government Press, Agartala for publication in the next issue of Tripura Gazette.
18. Guard File.

07/08
Addl. Secretary to the
Government of Tripura.

//True copy//

195

No. F. 4-234/SCW/STAT/2018/23113-213
GOVERNMENT OF TRIPURA
DEPARTMENT FOR WELFARE OF SCs
TRIPURA :: AGARTALA

Date, 1/13/2019.

NOTIFICATION

The Governor is pleased to constitute the Sub-Division Level Vigilance Committee as per section-24, Chapter-VII of the Prohibition of Employment as Manual Scavengers and their Rehabilitation Act, 2013.

The Sub-Division Vigilance Committee for each Sub-Division consisting of the Chairperson, Member and Member-Secretary are as follows:-

1. Sadar Sub-Division.
Agartala, West Tripura District

Sl. No.	Designation	Status in the Committee
1	Sub-Divisional Magistrate, Ex -Officio	Chairperson
2	Chairperson and Chief Executive Officer of Panehayat Samiti (to be nominated by the Sub-Divisional Magistrate), Ex -Officio.	Member
3	Sub-Divisional Police Officer, Ex -Officio.	Member
4	Chief Executive Officer / Executive Officer of Municipality of Sub- Divisional Head Quarter.	Member
5	2(two) Social Workers belonging to the organization working for the prohibition of Manual Scavenging and Rehabilitation of the Manual Scavengers; (to be nominated by the Sub- Divisional Magistrate), one of whom shall be woman.	Member
6	One person to represent the Financial and Credit Institutions in the Sub-Division (to be nominated by the Sub- Divisional Magistrate)	Member
7	Sub- Divisional Welfare Officer.	Member-Secretary

2. Jirania Sub-Division.
Jirania, West Tripura District

Sl. No.	Designation	Status in the Committee
1	Sub-Divisional Magistrate, Ex -Officio	Chairperson
2	Chairperson and Chief Executive Officer of Panchayat Samiti (to be nominated by the Sub-Divisional Magistrate), Ex -Officio.	Member
3	Sub-Divisional Police Officer, Ex -Officio.	Member
4	Chief Executive Officer / Executive Officer of Municipality of Sub- Divisional Head Quarter.	Member
5	2(two) Social Workers belonging to the organization working for the prohibition of Manual Scavenging and Rehabilitation of the Manual Scavengers, (to be nominated by the Sub- Divisional Magistrate), one of whom shall be woman.	Member
6	One person to represent the Financial and Credit Institutions in the Sub-Division (to be nominated by the Sub- Divisional Magistrate)	Member
7	Sub- Divisional Welfare Officer.	Member-Secretary

True copy!!

6 186

3. Mohanpur Sub-Division.
Mohanpur, West Tripura District

Sl. No.	Designation	Status in the Committee
1	Sub-Divisional Magistrate, Ex -Officio	Chairperson
2	Chairperson and Chief Executive Officer of Panchayat Samiti (to be nominated by the Sub-Divisional Magistrate), Ex -Officio.	Member
3	Sub-Divisional Police Officer, Ex -Officio.	Member
4	Chief Executive Officer / Executive Officer of Municipality of Sub-Divisional Head Quarter.	Member
5	2(two) Social Workers belonging to the organization working for the prohibition of Manual Scavenging and Rehabilitation of the Manual Scavengers, (to be nominated by the Sub-Divisional Magistrate), one of whom shall be woman.	Member
6	One person to represent the Financial and Credit Institutions in the Sub-Division (to be nominated by the Sub-Divisional Magistrate)	Member
7	Sub-Divisional Welfare Officer.	Member-Secretary

4. Khowai Sub-Division.
Khowai, Khowai Tripura District

Sl. No.	Designation	Status in the Committee
1	Sub-Divisional Magistrate, Ex -Officio	Chairperson
2	Chairperson and Chief Executive Officer of Panchayat Samiti (to be nominated by the Sub-Divisional Magistrate), Ex -Officio.	Member
3	Sub-Divisional Police Officer, Ex -Officio.	Member
4	Chief Executive Officer / Executive Officer of Municipality of Sub-Divisional Head Quarter.	Member
5	2(two) Social Workers belonging to the organization working for the prohibition of Manual Scavenging and Rehabilitation of the Manual Scavengers, (to be nominated by the Sub-Divisional Magistrate), one of whom shall be woman.	Member
6	One person to represent the Financial and Credit Institutions in the Sub-Division (to be nominated by the Sub-Divisional Magistrate)	Member
7	Sub-Divisional Welfare Officer.	Member-Secretary

//True copy//

187

7

4000 6177



5. Teliamura Sub-Division.
Teliamura, Khowai Tripura District

Sl. No.	Designation	Status in the Committee
1	Sub-Divisional Magistrate, Ex -Officio.	Chairperson
2	Chairperson and Chief Executive Officer of Panchayat Samiti (to be nominated by the Sub-Divisional Magistrate), Ex -Officio.	Member
3	Sub-Divisional Police Officer, Ex -Officio.	Member
4	Chief Executive Officer / Executive Officer of Municipality of Sub-Divisional Head Quarter.	Member
5	2(two) Social Workers belonging to the organization working for the prohibition of Manual Scavenging and Rehabilitation of the Manual Scavengers, (to be nominated by the Sub-Divisional Magistrate), one of whom shall be woman.	Member
6	One person to represent the Financial and Credit Institutions in the Sub-Division (to be nominated by the Sub-Divisional Magistrate)	Member
7	Sub-Divisional Welfare Officer.	Member-Secretary

6. Bishalgarh Sub-Division.
Bishalgarh, Sepahijala Tripura District

Sl. No.	Designation	Status in the Committee
1	Sub-Divisional Magistrate, Ex -Officio	Chairperson
2	Chairperson and Chief Executive Officer of Panchayat Samiti (to be nominated by the Sub-Divisional Magistrate), Ex -Officio.	Member
3	Sub-Divisional Police Officer, Ex -Officio.	Member
4	Chief Executive Officer / Executive Officer of Municipality of Sub-Divisional Head Quarter.	Member
5	2(two) Social Workers belonging to the organization working for the prohibition of Manual Scavenging and Rehabilitation of the Manual Scavengers, (to be nominated by the Sub-Divisional Magistrate), one of whom shall be woman.	Member
6	One person to represent the Financial and Credit Institutions in the Sub-Division (to be nominated by the Sub-Divisional Magistrate)	Member
7	Sub-Divisional Welfare Officer.	Member-Secretary

11/10/2011 True copy!!
198

7. Sonamura Sub-Division.
Sonamura, Sepahijala Tripura District

Sl. No.	Designation	Status in the Committee
1	Sub-Divisional Magistrate, Ex -Officio	Chairperson
2	Chairperson and Chief Executive Officer of Panchayat Samiti (to be nominated by the Sub-Divisional Magistrate), Ex -Officio.	Member
3	Sub-Divisional Police Officer, Ex -Officio.	Member
4	Chief Executive Officer / Executive Officer of Municipality of Sub-Divisional Head Quarter.	Member
5	2(two) Social Workers belonging to the organization working for the prohibition of Manual Scavenging and Rehabilitation of the Manual Scavengers, (to be nominated by the Sub-Divisional Magistrate), one of whom shall be woman.	Member
6	One person to represent the Financial and Credit Institutions in the Sub-Division (to be nominated by the Sub-Divisional Magistrate)	Member
7	Sub-Divisional Welfare Officer.	Member-Secretary

8. Jampuijala Sub-Division.
Jampuijala, Sepahijala Tripura District

Sl. No.	Designation	Status in the Committee
1	Sub-Divisional Magistrate, Ex -Officio	Chairperson
2	Chairperson and Chief Executive Officer of Panchayat Samiti (to be nominated by the Sub-Divisional Magistrate), Ex -Officio.	Member
3	Sub-Divisional Police Officer, Ex -Officio.	Member
4	Chief Executive Officer / Executive Officer of Municipality of Sub-Divisional Head Quarter.	Member
5	2(two) Social Workers belonging to the organization working for the prohibition of Manual Scavenging and Rehabilitation of the Manual Scavengers, (to be nominated by the Sub-Divisional Magistrate), one of whom shall be woman.	Member
6	One person to represent the Financial and Credit Institutions in the Sub-Division (to be nominated by the Sub-Divisional Magistrate)	Member
7	Sub-Divisional Welfare Officer.	Member-Secretary

//True copy//

189

9. Udaipur Sub-Division.
Udaipur, Gomati Tripura District

Sl. No.	Designation	Status in the Committee
1	Sub-Divisional Magistrate, Ex -Officio	Chairperson
2	Chairperson and Chief Executive Officer of Panchayat Samiti (to be nominated by the Sub-Divisional Magistrate), Ex -Officio.	Member
3	Sub-Divisional Police Officer, Ex -Officio.	Member
4	Chief Executive Officer / Executive Officer of Municipality of Sub- Divisional Head Quarter.	Member
5	2(two) Social Workers belonging to the organization working for the prohibition of Manual Scavenging and Rehabilitation of the Manual Scavengers, (to be nominated by the Sub- Divisional Magistrate), one of whom shall be woman.	Member
6	One person to represent the Financial and Credit Institutions in the Sub-Division (to be nominated by the Sub- Divisional Magistrate)	Member
7	Sub- Divisional Welfare Officer.	Member-Secretary

10. Amarpur Sub-Division.
Amarpur, Gomati Tripura District

Sl. No.	Designation	Status in the Committee
1	Sub-Divisional Magistrate, Ex -Officio	Chairperson
2	Chairperson and Chief Executive Officer of Panchayat Samiti (to be nominated by the Sub-Divisional Magistrate), Ex -Officio.	Member
3	Sub-Divisional Police Officer, Ex -Officio.	Member
4	Chief Executive Officer / Executive Officer of Municipality of Sub- Divisional Head Quarter.	Member
5	2(two) Social Workers belonging to the organization working for the prohibition of Manual Scavenging and Rehabilitation of the Manual Scavengers, (to be nominated by the Sub- Divisional Magistrate), one of whom shall be woman.	Member
6	One person to represent the Financial and Credit institutions in the Sub-Division (to be nominated by the Sub- Divisional Magistrate)	Member
7	Sub- Divisional Welfare Officer.	Member-Secretary

//True copy//

190

11. Karbook Sub-Division.
Karbook, Gomati Tripura District

Sl. No.	Designation	Status in the Committee
1	Sub-Divisional Magistrate, Ex -Officio	Chairperson
2	Chairperson and Chief Executive Officer of Panchayat Samiti (to be nominated by the Sub-Divisional Magistrate), Ex -Officio.	Member
3	Sub-Divisional Police Officer, Ex -Officio.	Member
4	Chief Executive Officer / Executive Officer of Municipality of Sub- Divisional Head Quarter.	Member
5	2(two) Social Workers belonging to the organization working for the prohibition of Manual Scavenging and Rehabilitation of the Manual Scavengers, (to be nominated by the Sub- Divisional Magistrate), one of whom shall be woman.	Member
6	One person to represent the Financial and Credit Institutions in the Sub-Division (to be nominated by the Sub- Divisional Magistrate)	Member
7	Sub- Divisional Welfare Officer.	Member-Secretary

12. Belonia Sub-Division.
Belonia, South Tripura District

Sl. No.	Designation	Status in the Committee
1	Sub-Divisional Magistrate, Ex -Officio	Chairperson
2	Chairperson and Chief Executive Officer of Panchayat Samiti (to be nominated by the Sub-Divisional Magistrate), Ex -Officio.	Member
3	Sub-Divisional Police Officer, Ex -Officio.	Member
4	Chief Executive Officer / Executive Officer of Municipality of Sub- Divisional Head Quarter.	Member
5	2(two) Social Workers belonging to the organization working for the prohibition of Manual Scavenging and Rehabilitation of the Manual Scavengers, (to be nominated by the Sub- Divisional Magistrate), one of whom shall be woman.	Member
6	One person to represent the Financial and Credit Institutions in the Sub-Division (to be nominated by the Sub- Divisional Magistrate)	Member
7	Sub- Divisional Welfare Officer.	Member-Secretary

//True copy//

191

13. Santirbazar Sub-Division.
Santirbazar, South Tripura District

Sl. No.	Designation	Status in the Committee
1	Sub-Divisional Magistrate, Ex -Officio	Chairperson
2	Chairperson and Chief Executive Officer of Panchayat Samiti (to be nominated by the Sub-Divisional Magistrate), Ex -Officio.	Member
3	Sub-Divisional Police Officer, Ex -Officio.	Member
4	Chief Executive Officer / Executive Officer of Municipality of Sub-Divisional Head Quarter.	Member
5	2(two) Social Workers belonging to the organization working for the prohibition of Manual Scavenging and Rehabilitation of the Manual Scavengers, (to be nominated by the Sub-Divisional Magistrate), one of whom shall be woman.	Member
6	One person to represent the Financial and Credit Institutions in the Sub-Division (to be nominated by the Sub-Divisional Magistrate)	Member
7	Sub-Divisional Welfare Officer.	Member-Secretary

14. Sabroom Sub-Division.
Sabroom, South Tripura District

Sl. No.	Designation	Status in the Committee
1	Sub-Divisional Magistrate, Ex -Officio	Chairperson
2	Chairperson and Chief Executive Officer of Panchayat Samiti (to be nominated by the Sub-Divisional Magistrate), Ex -Officio.	Member
3	Sub-Divisional Police Officer, Ex -Officio.	Member
4	Chief Executive Officer / Executive Officer of Municipality of Sub-Divisional Head Quarter.	Member
5	2(two) Social Workers belonging to the organization working for the prohibition of Manual Scavenging and Rehabilitation of the Manual Scavengers, (to be nominated by the Sub-Divisional Magistrate), one of whom shall be woman.	Member
6	One person to represent the Financial and Credit Institutions in the Sub-Division (to be nominated by the Sub-Divisional Magistrate)	Member
7	Sub-Divisional Welfare Officer.	Member-Secretary

//True copy//

192

15. Kanchanpur Sub-Division.
Kanchanpur, North Tripura District

Sl. No.	Designation	Status in the Committee
1	Sub-Divisional Magistrate, Ex -Officio	Chairperson
2	Chairperson and Chief Executive Officer of Panchayat Samiti (to be nominated by the Sub-Divisional Magistrate), Ex -Officio.	Member
3	Sub-Divisional Police Officer, Ex -Officio.	Member
4	Chief Executive Officer / Executive Officer of Municipality of Sub- Divisional Head Quarter.	Member
5	2(two) Social Workers belonging to the organization working for the prohibition of Manual Scavenging and Rehabilitation of the Manual Scavengers, (to be nominated by the Sub- Divisional Magistrate), one of whom shall be woman.	Member
6	One person to represent the Financial and Credit Institutions in the Sub-Division (to be nominated by the Sub- Divisional Magistrate)	Member
7	Sub- Divisional Welfare Officer.	Member-Secretary

16. Dharmanagar Sub-Division.
Dharamanagar, North Tripura District

Sl. No.	Designation	Status in the Committee
1	Sub-Divisional Magistrate, Ex -Officio	Chairperson
2	Chairperson and Chief Executive Officer of Panchayat Samiti (to be nominated by the Sub-Divisional Magistrate), Ex -Officio.	Member
3	Sub-Divisional Police Officer, Ex -Officio.	Member
4	Chief Executive Officer / Executive Officer of Municipality of Sub- Divisional Head Quarter.	Member
5	2(two) Social Workers belonging to the organization working for the prohibition of Manual Scavenging and Rehabilitation of the Manual Scavengers, (to be nominated by the Sub- Divisional Magistrate), one of whom shall be woman.	Member
6	One person to represent the Financial and Credit Institutions in the Sub-Division (to be nominated by the Sub- Divisional Magistrate)	Member
7	Sub- Divisional Welfare Officer.	Member-Secretary

//True copy//

193

17. Panisagar Sub-Division.
Panisagar, North Tripura District

Sl. No.	Designation	Status in the Committee
1	Sub-Divisional Magistrate, Ex -Officio	Chairperson
2	Chairperson and Chief Executive Officer of Panchayat Samiti (to be nominated by the Sub-Divisional Magistrate), Ex -Officio.	Member
3	Sub-Divisional Police Officer, Ex -Officio.	Member
4	Chief Executive Officer / Executive Officer of Municipality of Sub- Divisional Head Quarter.	Member
5	2(two) Social Workers belonging to the organization working for the prohibition of Manual Scavenging and Rehabilitation of the Manual Scavengers, (to be nominated by the Sub- Divisional Magistrate), one of whom shall be woman.	Member
6	One person to represent the Financial and Credit Institutions in the Sub-Division (to be nominated by the Sub- Divisional Magistrate)	Member
7	Sub- Divisional Welfare Officer.	Member-Secretary

18. Kailashahar Sub-Division.
Kailashahar, Unakoti District.

Sl. No.	Designation	Status in the Committee
1	Sub-Divisional Magistrate, Ex -Officio	Chairperson
2	Chairperson and Chief Executive Officer of Panchayat Samiti (to be nominated by the Sub-Divisional Magistrate), Ex -Officio.	Member
3	Sub-Divisional Police Officer, Ex -Officio.	Member
4	Chief Executive Officer / Executive Officer of Municipality of Sub- Divisional Head Quarter.	Member
5	2(two) Social Workers belonging to the organization working for the prohibition of Manual Scavenging and Rehabilitation of the Manual Scavengers, (to be nominated by the Sub- Divisional Magistrate), one of whom shall be woman.	Member
6	One person to represent the Financial and Credit Institutions in the Sub-Division (to be nominated by the Sub- Divisional Magistrate)	Member
7	Sub- Divisional Welfare Officer.	Member-Secretary

194
True copy//
19/7/13

19. Kumarghat Sub-Division.
Kumarghat, Unakoti District.

Sl. No.	Designation	Status in the Committee
1	Sub-Divisional Magistrate, Ex -Officio	Chairperson
2	Chairperson and Chief Executive Officer of Panchayat Samiti (to be nominated by the Sub-Divisional Magistrate), Ex -Officio.	Member
3	Sub-Divisional Police Officer, Ex -Officio.	Member
4	Chief Executive Officer / Executive Officer of Municipality of Sub-Divisional Head Quarter.	Member
5	2(two) Social Workers belonging to the organization working for the prohibition of Manual Scavenging and Rehabilitation of the Manual Scavengers, (to be nominated by the Sub-Divisional Magistrate), one of whom shall be woman.	Member
6	One person to represent the Financial and Credit Institutions in the Sub-Division (to be nominated by the Sub-Divisional Magistrate)	Member
7	Sub-Divisional Welfare Officer.	Member-Secretary

20. Kamalpur Sub-Division.
Kamalpur, Dhalai District.

Sl. No.	Designation	Status in the Committee
1	Sub-Divisional Magistrate, Ex -Officio	Chairperson
2	Chairperson and Chief Executive Officer of Panchayat Samiti (to be nominated by the Sub-Divisional Magistrate), Ex -Officio.	Member
3	Sub-Divisional Police Officer, Ex -Officio.	Member
4	Chief Executive Officer / Executive Officer of Municipality of Sub-Divisional Head Quarter.	Member
5	2(two) Social Workers belonging to the organization working for the prohibition of Manual Scavenging and Rehabilitation of the Manual Scavengers, (to be nominated by the Sub-Divisional Magistrate), one of whom shall be woman.	Member
6	One person to represent the Financial and Credit Institutions in the Sub-Division (to be nominated by the Sub-Divisional Magistrate)	Member
7	Sub-Divisional Welfare Officer.	Member-Secretary

//True copy//

195

25

21. Ambassa Sub-Division.
Ambassa, Dhalai District.

Sl. No.	Designation	Status in the Committee
1	Sub-Divisional Magistrate, Ex -Officio	Chairperson
2	Chairperson and Chief Executive Officer of Panchayat Samiti (to be nominated by the Sub-Divisional Magistrate), Ex -Officio.	Member
3	Sub-Divisional Police Officer, Ex -Officio.	Member
4	Chief Executive Officer / Executive Officer of Municipality of Sub-Divisional Head Quarter.	Member
5	2(two) Social Workers belonging to the organization working for the prohibition of Manual Scavenging and Rehabilitation of the Manual Scavengers, (to be nominated by the Sub-Divisional Magistrate), one of whom shall be woman.	Member
6	One person to represent the Financial and Credit Institutions in the Sub-Division (to be nominated by the Sub-Divisional Magistrate)	Member
7	Sub-Divisional Welfare Officer.	Member-Secretary

22. Longtharai Valley Sub-Division.
LTV, Dhalai District.

Sl. No.	Designation	Status in the Committee
1	Sub-Divisional Magistrate, Ex -Officio	Chairperson
2	Chairperson and Chief Executive Officer of Panchayat Samiti (to be nominated by the Sub-Divisional Magistrate), Ex -Officio.	Member
3	Sub-Divisional Police Officer, Ex -Officio.	Member
4	Chief Executive Officer / Executive Officer of Municipality of Sub-Divisional Head Quarter.	Member
5	2(two) Social Workers belonging to the organization working for the prohibition of Manual Scavenging and Rehabilitation of the Manual Scavengers, (to be nominated by the Sub-Divisional Magistrate), one of whom shall be woman.	Member
6	One person to represent the Financial and Credit Institutions in the Sub-Division (to be nominated by the Sub-Divisional Magistrate)	Member
7	Sub-Divisional Welfare Officer.	Member-Secretary

//True copy//

156

16

1900 9/11/11

**23. Gandhacharra Sub-Division.
Gandhacharra, Dhalai District.**

Sl. No.	Designation	Status in the Committee
1	Sub-Divisional Magistrate, Ex -Officio	Chairperson
2	Chairperson and Chief Executive Officer of Panchayat Samiti (to be nominated by the Sub-Divisional Magistrate), Ex -Officio.	Member
3	Sub-Divisional Police Officer, Ex -Officio.	Member
4	Chief Executive Officer / Executive Officer of Municipality of Sub- Divisional Head Quarter.	Member
5	2(two) Social Workers belonging to the organization working for the prohibition of Manual Scavenging and Rehabilitation of the Manual Scavengers, (to be nominated by the Sub- Divisional Magistrate), one of whom shall be woman.	Member
6	One person to represent the Financial and Credit institutions in the Sub-Division (to be nominated by the Sub- Divisional Magistrate)	Member
7	Sub- Divisional Welfare Officer.	Member-Secretary

Each Vigilance Committee at the Sub -Division Level shall meet at least once in every three months in regard to implementation of the M S Act-2013.

Functions of Vigilance Committee shall be-

- to advise the District Magistrate or, as the case may be, the Sub-Divisional Magistrate, on the action which needs to be taken, to ensure that the provisions of this Act, or of any rule made thereunder are properly implemented;
- to oversee the economic and social rehabilitation of Manual Scavengers;
- to co-ordinate the functions of all concerned agencies with a view to channelise adequate credit for the rehabilitation of Manual Scavenger;
- to monitor the registration of offences under this Act and their investigation and prosecution.

This will take immediate effect.

 (Ratan Biswas)
 Addl. Secretary to the
 Government of Tripura.

01/03
 2018

Copy to:-

- The Principal Secretary to the Chief Minister for information of the Hon'ble Chief Minister.
- The Private Secretary to the Minister for Welfare of Sch. Castes for information of the Hon'ble Minister.
- The P.S/P.A to the Minister _____ for information of the Hon'ble Minister.
- The P.S to the Chief Secretary for information of the Chief Secretary.
- The Secretary, National Commission for Safai Karamcharis, Ministry of Social Justice & Empowerment, Govt. of India for Information.

17 197

//True copy//

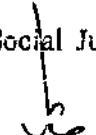
 01/03
 2018

6. The Addl. Secretary, Ministry of Social Justice & Empowerment, Govt. of India for Information.
7. All Principal Secretaries / Commissioner / Secretaries to the Govt. of Tripura.
8. All Heads of Department Govt. of Tripura _____ for information and necessary action.
9. The District Magistrate & Collector - North/ Unakoti / Dhalai/ Khowai/ West/ Sepahijala/ Gomati and South Tripura District.
10. The District Welfare Officer - North/ Unakoti/ Dhalai/ Khowai/ West/ Sepahijala/ Gomati and South Tripura.
11. The Sub-Divisional Magistrate- Dharmanagar /Panisagar/ Kanchanpur/ Kumarghat/ Kailashahar/ Longthorai valley / Ambassa/ Kamalpur/ Gandachara/ Teliamura/ Khowai/ Jirania/ Sadar/ Mohanpur/ Bishalgarh/ Jampuijala/ Sonamura/ Udaipur/ Amarpur/ Karbook/ Belonia/ Santirbazar/ Sabroom Sub-Division for information and necessary action.
12. The Sub Divisional Welfare Officer- Dharmanagar /Panisagar/ Kanchanpur/ Kumarghat/ Kailashahar/ Longthorai valley / Ambassa/ Kamalpur/ Gandachara/ Teliamura/ Khowai/ Jirania/ Sadar/ Mohanpur/ Bishalgarh/ Jampuijala/ Sonamura/ Udaipur/ Amarpur/ Karbook/ Belonia/ Santirbazar/ Sabroom Sub-Division for information and necessary action.
13. The Chief Executive Officer/Executive Officer, _____ AMC/MC/NP for information and necessary action.
14. The Block Development Officer, _____ Block for information and necessary action.
15. All Members of the SC Welfare Sub-Committee, _____ AMC/MC/NP / under -----Block for information and necessary action.
16. The Manager, Tripura Government Press, Agartala for publication in the next issue of Tripura Gazette.

 Addl. Secretary to the
 Government of Tripura.

//True copy//

198

No.F.A-234/SCW/STAT/2018/1686-78
GOVERNMENT OF TRIPURA
DEPARTMENT FOR WELFARE OF SCHEDULED CASTES
TRIPURA : : AGARTALA

Date, 04/05/2021.

NOTIFICATION

In exercise of the power conferred by sub-section (i) of section 32 of the Prohibition of Employment as Manual Scavenger and their Rehabilitation Act, 2013, (25 of 2013), the Government of Tripura hereby designates the Tripura State Commission for Safai Karamcharies appointing the following as its Chairman & Members:-

Sl. No.	Name	Designation
1.	Secretary, SC Welfare Deptt.	Chairman
2.	Director, SC Welfare Deptt. Ex-officio	Member
3.	Sri Gopal Sarkar, Betabar, Kemper Bazar, Social Activist,	Member
4.	Joint Director SC Welfare Department.	Member-Secretary.
5.	Joint Director / Deputy Director, Urban Dev. Deptt.	Member

The terms of office and conditions of the Chairman and Members shall be notified separately.

my 29.4.2021
(Animesh Das)

Deputy Secretary to the
Government of Tripura.

Copy to:

1. Principal Secretary to the Governor of Tripura.
2. P.S to the Chairman, National Commission for Safai Karamcharis, New Delhi.
3. P.S to the Chief Minister for kind information of the Hon'ble Chief Minister.
4. P.S to the Minister, SC Welfare Department, Govt. of Tripura for kind information of the Minister.
5. P.S to the Chief Secretary, Govt. of Tripura for kind information of the Chief Secretary.
6. Addl. Chief Secretary, Govt. of Tripura for kind information.
7. Principal Secretary, Govt. of Tripura for kind information.
8. All Heads of Departments for information.
9. All D.M & Collectors for information.
10. MD / CEO all PSUs/Organization Urban Local Bodies Corporations/ Govt. under taking.
11. General Manager, Printing & Stationary for kind information.

//True copy//
S

my 29.4.2021
(Animesh Das)

Deputy Secretary to the
Government of Tripura.

प्रेषक,

नन्द किशोर शर्मा,

संयुक्त सचिव,

उत्तर प्रदेश शासना।

सेवा में,

उप सचिव,

सामाजिक न्याय और अधिकारिता मंत्रालय,

भारत सरकार, नई दिल्ली।

कल्याण नियोजन प्रकोष्ठ

लखनऊ: दिनांक: 10 जनवरी, 2024

समाज कल्याण विभाग

विषय: मा0 सर्वोच्च न्यायालय में दाखिल पी0आई0एल0 रिट सं0- 324/2020 डा0 बलराम सिंह बनाम यूनियन ऑफ इण्डिया एवं अन्य के संबंध में पारित आदेश दिनांक 20.10.2023 के संदर्भ में।

महोदय,

उपर्युक्त विषयक अपने पत्र सं0- U-12012/01/2023 (Plan) दिनांक 02.01.2024, तथा समसंख्यक पत्र दिनांक 14.11.2023 पत्र सं0- U-12012/01/2023 (Plan) दिनांक 15.12.2023 तथा समसंख्यक पत्र दिनांक 14.11.2023 का कृपया संदर्भ ग्रहण करने का कष्ट करें, जिसके अन्तर्गत मा0 सर्वोच्च न्यायालय में दाखिल पी0आई0एल0 रिट सं0- 324/2020 डा0 बलराम सिंह बनाम यूनियन ऑफ इण्डिया एवं अन्य के संबंध में पारित आदेश दिनांक 20.10.2023 का अनुपालन सुनिश्चित किये जाने के संबंध में दिनांक 08.01.2024 तक अन्तरिम उपलब्ध कराये जाने की अपेक्षा की गयी है।

2- अवगत कराना है कि मा0 सर्वोच्च न्यायालय में दाखिल पी0आई0एल0 रिट सं0- 324/2020 डा0 बलराम सिंह बनाम यूनियन ऑफ इण्डिया एवं अन्य में मा0 उच्चतम न्यायालय द्वारा पारित आदेश दिनांक 20.10.2023 में दिये गये निर्देशों का अनुपालन किये जाने के संबंध में सचिव, समाज कल्याण की अध्यक्षता में दिनांक 06.12.2023 को एक बैठक आयोजित की गयी थी। उक्त बैठक का कार्यवृत्त कल्याण नियोजन प्रकोष्ठ के पत्र सं0-1015/का0नि0प्र0/26-3-2023 दिनांक 13.12.2023 (छायाप्रति संलग्न) द्वारा निर्गत करते हुए संबंधित विभागों को मा0 न्यायालय के आदेशों के अनुपालन किये जाने के संबंध में अपेक्षित कार्यवाही किये जाने हेतु निर्देशित किया गया है।

3- यह भी अवगत कराना है कि समाज कल्याण विभाग, उ0प्र0 शासन द्वारा रिट सं0- 324/2020 (पी0आई0एल0) डा0 बलराम सिंह बनाम यूनियन ऑफ इण्डिया एवं अन्य में मा0 उच्चतम न्यायालय द्वारा पारित आदेश दिनांक 20.10.2023 के पैरा- 96 के (4) एवं (5) में दिये गये निर्देशानुसार सीवर/सैप्टिक टैंक की घातक सफाई में मृत मैनुअल स्कैवेन्जर के आश्रित परिजन/विकलांग हुए मैनुअल स्कैवेन्जर को क्षतिपूर्ति दिये जाने हेतु कल्याण नियोजन प्रकोष्ठ

के पत्र सं0-1008/क0नि0प्र0/26-3-2023 दिनांक 12.12.2023 (छायाप्रति संलग्न) द्वारा संबंधित विभागो को निर्देश निर्गत कर दिये गये है।

4- उक्त के अतिरिक्त आपके उक्त समसंख्यक पत्र दिनांक 14.11.2023 की गयी अपेक्षा के क्रम में यह भी सूच्य है कि कल्याण नियोजन प्रकोष्ठ, समाज कल्याण विभाग के अधिसूचना सं0- 354-KNP/XXVI-3-2014-13(60)-2013 दिनांक 03.06.2014 (प्रति संलग्न) द्वारा उ0प्र0राज्य सफाई कर्मचारी आयोग, अधिसूचना सं0-1761/कनिप्र-26-3-2014-13(60)-2013 दिनांक 31.12.2014 (प्रति संलग्न) द्वारा स्टेट लेवल सर्वे कमेटी, डिस्ट्रिक्ट लेवल सर्वे कमेटी, अधिसूचना सं0-106 KNP/XXVI-3-2014-13(60)-2013 दिनांक 21.05.2014 (प्रति संलग्न) द्वारा राज्य मानीटरिंग ममिति, अधिसूचना सं0-689 KNP/XXVI-3-2014-13(60)-2013 दिनांक 28.05.2014 (प्रति संलग्न) द्वारा जिला निगरानी समिति तथा अधिसूचना सं0-690 KNP/XXVI-3-2014-13(60)-2013 दिनांक 28.05.2014 (प्रति संलग्न) द्वारा उप जिला स्तर निगरानी समिति के गठन संबंधी कार्यवाही पूर्व में की जा चुकी है।

5- अतः इस संबंध में मुझे यह कहने का निदेश हुआ है कि कृपया उक्त वर्णित स्थिति से अवगत होते हुए प्रकरण में अग्रेतर आवश्यक कार्यवाही करने का कष्ट करें।

संलग्नक:- यथोक्त।

भवदीय,

Digitally Signed by नन्द

किशोर शर्मा (किशोर शर्मा)

Date: 10/01/2024 10:11:54

Reason: Approved

//True copy//



13/12/2023
13/12/2023
13/12/2023
रिट पिटीशन (पीआईएल) नं०-324 आफ 2020 डा० बलराम सिंह बनाम यूनियन आफ इंडिया व अन्य में मा० उच्चतम न्यायालय द्वारा पारित आदेश दिनांक 20.10.2023 में पारित आदेशों एवं मा० राष्ट्रीय मानवाधिकार आयोग के आदेश दिनांक 31.10.2023 द्वारा दिये गये आदेशों का अनुपालन किये जाने के संबंध में दिनांक 06.12.2023 को सचिव समाज कल्याण विभाग की अध्यक्षता में आयोजित बैठक का कार्यवृत्त।

रिट पिटीशन संख्या-324/2020 डा० बलराम सिंह बनाम यूनियन आफ इंडिया व अन्य में मा० उच्चतम न्यायालय द्वारा पारित निर्णय दिनांक 20-10-2023 एवं मा० राष्ट्रीय मानवाधिकार आयोग के आदेश दिनांक 31-10-2023 में दिये गये आदेशों के अनुपालन के संबंध में विचार-विमर्श हेतु दिनांक 06-12-2023 को प्रमुख सचिव महोदय की अध्यक्षता में एक बैठक प्रस्तावित की गयी थी, जिसकी अध्यक्षता सचिव महोदय द्वारा की गयी। प्रश्नगत बैठक में निम्नलिखित अधिकारियों द्वारा प्रतिभाग किया गया:-

1. श्री राधेश्याम, प्रबन्ध निदेशक, उ०प्र० अनुसूचित जाति वित्त एवं विकास निगम लि० लखनऊ।
2. श्री नन्द किशोर शर्मा, संयुक्त सचिव, समाज कल्याण विभाग, उ०प्र० शासन।
3. श्री कुलदीप बाबू, संयुक्त सचिव, व्यायसायिक शिक्षा, उ०प्र० शासन।
4. श्री महावीर प्रसाद बघेल, संयुक्त सचिव, नगर विकास विभाग, उ०प्र० शासन।
5. श्री गिरीश कुमार, उप सचिव, पंचायतीराज विभाग।
6. डा० मोहम्मद असलम अंसारी, अपर निदेशक, स्थानीय निकाय निदेशालय।
7. श्री जे०राम, महाप्रबन्धक, उ०प्र० अनुसूचित जाति वित्त एवं विकास निगम लि० लखनऊ।
8. श्री नदीम सिद्दीकी, जिला समाज कल्याण अधिकारी, समाज कल्याण निदेशालय।
9. श्री संदीप चौहान, निदेशालय, स्थानीय निकाय, उ०प्र०।
10. श्री मनोज कुमार त्यागी, पंचायतीराज विभाग।

बैठक का शुभारम्भ करते हुए सचिव महोदय द्वारा संबंधित विभागों से विचार-विमर्श के उपरान्त निम्नवत् निर्देश दिए गये:-

क्र.सं.	मा० उच्चतम न्यायालय के आदेश	बैठक में दिये गये निर्देश
i.	The Union should take appropriate measures and frame policies, and issue directions to all statutory bodies, including corporations, railways, cantonments, as well as agencies under its control, to ensure that manual sewer cleaning is completely eradicated in a phased manner, and also issue such guidelines and directions as are essential, that any sewer cleaning work outsourced, or required to be discharged by or through contractors or agencies, do not require individuals to enter sewers, for any purpose whatsoever.	<p>इस संबंध में नगर विकास विभाग द्वारा अवगत कराया गया कि उ०प्र० में चरणबद्ध रूप से कार्य कराते हुए वर्ष 2026 तक सीवर लाइन बनाने का कार्य पूर्ण होगा। अतएव उनके द्वारा उक्त स्थिति से राष्ट्रीय मानवाधिकार आयोग को अवगत कराया जा चुका है।</p> <p>इस संबंध में विचार-विमर्श के उपरान्त सचिव महोदय द्वारा यह निर्देश दिये गये कि मा० उच्चतम न्यायालय के आदेश के अनुपालन में नगर विकास विभाग/ पंचायतीराज विभाग सक्षम स्तर से अनुमोदन प्राप्त करते हुए</p>

		अद्यतन शासनादेश जारी करेंगे, तथा तदनुसार मा0 राष्ट्रीय मानवाधिकार आयोग को अवगत करायेगे। (कार्यवाही- नगर विकास विभाग/ पंचायतीराज विभाग)
ii.	All States and Union Territories are likewise, directed to ensure that all departments, agencies, corporations, and other agencies (by whatever name called) ensure that guidelines and directions framed by the Union are embodied in their own guidelines and directions; the states are specifically directed to ensure that such directions are applicable to all municipalities, and local bodies functioning within their territories.	इस संबंध में नगर विकास विभाग/पंचायतीराज विभाग द्वारा अवगत कराया गया कि समाज कल्याण विभाग द्वारा निर्गत एम0एस0 एक्ट-2013 के संबंध में निर्गत नियमावली-2014 अधिसूचना सं0-1761/क0नि0 प्र0/26-3-2014- 13(60)-2013 को अंगीकृत (Adopt) किया जा चुका है। सचिव महोदय द्वारा निर्देश दिये गये कि मा0 उच्चतम् न्यायालय के आदेश के अनुपालन में नगर विकास विभाग एवं पंचायतीराज विभाग द्वारा संबंधित निकायों/अधिकारियों को आवश्यक निर्देश निर्गत करते हुए तदनुसार मा0 राष्ट्रीय मानवाधिकार आयोग को अवगत करायेगे। (कार्यवाही- नगर विकास विभाग/ पंचायतीराज विभाग)
iii.	The Union, State and Union Territories are directed to ensure that full rehabilitation (including employment to the next of kin, education to the wards, and skill training) measures are taken in respect of sewage workers, and those who die.	इस संबंध में पबन्ध निदेशक, अनुगम द्वारा यह अवगत कराया गया कि सीवर/ सैप्टिक टैंक की घातक सफाई में लगे मैनुअल स्कैवेजर्स को एम0एस0एक्ट-2013 की धारा-13 के अन्तर्गत उनका आई कार्ड बनाये जाने, छात्रवृत्ति दिये जाने, आवासीय भूखण्ड दिये जाने, वित्तीय सहायता दिये जाने, जीविकोपार्जन हेतु प्रशिक्षण दिये जाने इत्यादि का प्रविधान है। यह भी अवगत कराया गया कि मैनुअल स्कैवेजर्स के पुर्नवासन के संबंध में भारत सरकार की संस्था राष्ट्रीय सफाई कर्मचारी वित्त एवं विकास निगम (एन0एस0के0 एफ0डी0सी0) द्वारा एकमुश्त सहायता के रूप में रू0 40,000 की आर्थिक सहायता उपलब्ध करायी जाती है। निदेशक, समाज कल्याण के प्रतिनिधि

True copy//

//True copy//

उच्चतम न्यायालय के आदेश के क्रम में अगुआम द्वारा अवगत कराया गया कि मा 10 प्रशिक्षण दिया गया। प्रबन्ध निदेशक, तस्वदीपी एन0जी0जी0 के माध्यम से भी मैग्जल स्कैन्जर की सूची प्राप्त करते हुए किया गया है कि प्रबन्ध निदेशक, अगुआम के प्रशिक्षण दिया जाता है। उन्हें यह निर्देशित द्वारा समस्त लोगों को रोजगारपरक द्वारा यह अवगत कराया गया कि उनके संबंध में कौशल विकास विभाग के सदस्य कौशल प्रशिक्षण करने जाने के समान कल्याण द्वारा की गया।

संबंध में आवश्यक कार्यवाही निदेशक, संबंध है। प्रवेश-परीक्षा से मुक्त करने के मैग्जल स्कैन्जर के परिवार के छात्रों को अर्धीन ए0टी0एस0 आवासीय विद्यालय में करायी जाय। समान कल्याण विभाग के स्थापित कर अधीनस्थ कार्यवाही सुनिश्चित निदेशक, समान कल्याण से समन्वय छात्र को वर्गीकृत किया जाने के संबंध में स्कैन्जर परिवार के कक्षा 9 से 10 तक के को यह निर्देश दिये गये कि मैग्जल इस संबंध में प्रबन्ध निदेशक, अगुआम परिवारजन की संधा बतानी जाय।

विभाग द्वारा सेवायोजित किये गये नगर विकास विभाग एवं पंचायतीराज इस संबंध में यह निर्देश दिये गये कि उनके द्वारा निर्देश निरत किया गया है। परिवारजन का समायोजन कराये जाने हेतु धातक सफाई में मूल सफाईकर्मी के आश्रित कराया गया है कि सीवर/सैटिक टैंक की नगर विकास विभाग द्वारा यह अवगत सहायता प्रदान की जाती है।

कौशल प्रशिक्षण के दौरान रु0 3000/- की को एन0एस0के0एफ0 जी0सी0 द्वारा अवगत कराया गया कि विमुक्त स्वच्छकारी प्रबन्ध निदेशक, अगुआम द्वारा यह स्कांलरों प्रदान की जाती है।

स्कैन्जर के परिवार के-वर्गी-की द्वारा अवगत कराया गया कि मैग्जल

		<p>पुनर्वास के संबंध में एक नई नीति ब्रूनाये जाने की आवश्यकता है। सचिव महोदय द्वारा यह निर्देश दिये गये कि प्रबन्ध निदेशक, अनुगम इस संबंध में भारत सरकार से समन्वय कर एक सप्ताह में सूचना देगें।</p> <p>(कार्यवाही- नगर विकास विभाग/ पंचायतीराज विभाग/ निदेशक, समाज कल्याण/ प्रबन्ध निदेशक, अनुगम)</p>
iv	<p>The Court hereby directs the Union and the States to ensure that the compensation for sewer death is increased (given that the previous amount fixed i.e. Rs. 10lakhs) was made applicable from .1993 The current equivalent of that amount is Rs. 30lakhs. This shall be the amount to be paid, by the concerned agency i.e. the Union, the Union Territory or the State as the case may be. in other words, compensation for sewer deaths shall be Rs. 30lakhs, In the event, dependents of any victims have not paid such amount, the above amount shall be payable to them., Furthermore, this shall be the amount to be hereafter paid, as compensation.</p>	<p>सचिव महोदय द्वारा निर्देश दिये गये कि मा0 उच्चतम न्यायालये आदेशों के अनुपालन में निर्देश निर्गत किये जांय।</p> <p>(कार्यवाही कल्याण नियोजन प्रकोष्ठ, समाज कल्याण विभाग)</p>
v	<p>Likewise, in the case of sewer victims suffering disabilities, depending upon the severity of disabilities, compensation shall be disbursed. However, the minimum compensation shall not be less than Rs. 10Lakhs. If the disability is permanent and renders the victim economically helpless, the compensation shall not be less than Rs. 20lakhs.</p>	<p>सचिव महोदय द्वारा निर्देश दिये गये कि मा0 उच्चतम न्यायालय के आदेशों के अनुपालन में निर्देश निर्गत किये जांय।</p> <p>(कार्यवाही-कल्याण नियोजन प्रकोष्ठ, समाज कल्याण विभाग।)</p>

True copy"

205

<p>vi</p>	<p>The appropriate government (i.e. the Union, State or Union Territories) shall devise a suitable mechanism to ensure accountability, especially wherever sever deaths occur in the course of contractual or "outsourced" work. This accountability shall be in the form of cancellation of contract, forthwith and imposition of monetary liability, aimed at deterring the practice.</p>	<p>इस बिन्दु में यह कहा गया है कि मैनुअल स्कैवेन्जर जो कान्ट्रैक्ट के माध्यम से कार्य कर रहे हैं उनके लिए नई नीति बनायी जाय, जिसमें मृत्यु होने की दशा में उन पर आर्थिक दण्ड/ कान्ट्रैक्ट निरस्तीकरण नियम बनाये जाय। इस संबंध में यह निर्देश दिये गये कि आगामी समस्त कार्यों में मैनुअल स्कैवेन्जर की दुर्घटना की दशा में संविदा निरस्तीकरण/ आर्थिक दण्ड संबंधी प्राविधान किये जाय तथा एन0एच0आर0सी0 की आगामी बैठक में इस बिन्दु का उत्तर नगर विकास, पंचायतीराज विभाग द्वारा दिया जाय। (कार्यवाही- नगर विकास विभाग/ पंचायतीराज विभाग)</p>
<p>vii</p>	<p>The Union shall device a model contract, to be used wherever contracts are to be awarded, by it or its agencies and corporations, in the concerned enactment, such as the Contract Labour (Prohibition and Regulation Act), 1970, or any other law, which mandates the standards in conformity with the 2013Act, and rules, are strictly followed. and in the event of any mishap, the agency would lose its contract, and possibly blacklisting. This model shall also be used by all States and Union Territories.</p>	<p>इस संबंध में निर्देश दिया गया कि नगर विकास विभाग एवं पंचायतीराज विभाग द्वारा शासनादेश निर्गत किये जाय। (कार्यवाही- नगर विकास विभाग/ पंचायतीराज विभाग)</p>
<p>viii</p>	<p>The Union, State and Union Territories are hereby required to set up scholarships to ensure that the dependents of sewer victims (who have died, or might have suffered disabilities) are given meaningful education. disbursement, as well as rehabilitation measures taken, and existing and available rehabilitation policies shall be developed and launched at an early date.</p>	<p>इस संबंध में निर्देश दिये गये कि प्रबन्ध निदेश, अनुगम द्वारा निदेशक, समाज कल्याण से समन्वय कर नीति बनायी जाय। (कार्यवाही-निदेशक, समाज कल्याण/ प्रबन्ध निदेशक, अनुगम)</p>

True copy
206

ix	A portal and a dashboard containing all relevant information, including the information relating to sewer deaths and victims, and the status of compensation disbursement, as well as rehabilitation measures taken and existing and available rehabilitation policies shall be developed and launched at an early date.	सचिव महोदय द्वारा निर्देश दिये गये कि प्रबन्ध निदेशक, अनुगम द्वारा निदेशक, समाज कल्याण विभाग एवं भारत सरकार से जानकारी कर पोर्टल एवं डैश बोर्ड विकसित करने के संबंध में आवश्यक कार्यवाही की जाय। (कार्यवाही- प्रबन्ध निदेशक, अनुगम)
----	--------------------------------------------------------------------------------------------------------------------------------------------------------------------------------------------------------------------------------------------------------------------------------------------------------------------------	----------------------------------------------------------------------------------------------------------------------------------------------------------------------------------------------------------------------------------------

बैठक सधन्यवाद समाप्त हुयी।

Digitally Signed by (नन्द किशोर शर्मा)

किशोर शर्मा संयुक्त सचिव।

Date: 13-12-2023 16:19:35

Reason: Approved

उत्तर प्रदेश शासन
कल्याण नियोजन प्रकोष्ठ
समाज कल्याण विभाग

संख्या-1015 /क.नि.प्र./26-3-2023

लखनऊ: दिनांक: 13 दिसम्बर, 2023

पत्रावली कम्प्यू नं0 - 1675192

उपर्युक्त कार्यवृत्त की प्रतिलिपि निम्नलिखित को सूचनार्थ एवं आवश्यक कार्यवाही हेतु प्रेषित:-

1. सचिव, सामाजिक न्याय और अधिकारिता मंत्रालय, भारत सरकार, शास्त्री भवन, नई दिल्ली।
2. प्रमुख स्टाफ आफिसर, मुख्य सचिव, उत्तर प्रदेश शासन।
3. निजी सचिव, प्रमुख सचिव/ सचिव/ विशेष सचिव, समाज कल्याण विभाग, उ0प्र0 शासन।
4. अपर मुख्य सचिव/प्रमुख सचिव, नगर विकास विभाग एवं पंचायती राज विभाग, उ0प्र0 शासन को इस अनुरोध के साथ प्रेषित कि राष्ट्रीय मानवाधिकार आयोग की आगामी बैठक हेतु उपरोक्तानुसार कार्यवाही कराते हुए अपने से संबंधित बिन्दु की सूचना मा0आयोग को उपलब्ध कराने का कष्ट करें।
5. निदेशक, समाज कल्याण, उत्तर प्रदेश, लखनऊ।
6. प्रबन्ध निदेशक, उ0प्र0 अनुसूचित जाति वित्त एवं विकास निगम लि0, महानगर, लखनऊ।
7. बैठक में उपस्थित समस्त अधिकारीगण।
8. गार्ड फाइल।

207 //True copy//

आज्ञा से,

(नन्द किशोर शर्मा)
संयुक्त सचिव।

श्री० सर्वोच्च न्यायालय के आदेश/ समयबद्ध

संख्या- 1008 /क०नि०प्र०/26-3-2023

FILE COM. NO. 1672195

धरक,

श्री० हरिओम,

प्रमुख सचिव,

उत्तर प्रदेश शासन।

सेवा में,

1. अध्यक्ष,

नोयडा विकास प्राधिकरण,

नोयडा, गौतमबुद्ध नगर।

3. अपर मुख्य सचिव/प्रमुख सचिव/सचिव,

पंचायतीराज विभाग/नगर विकास विभाग/

आवास एवं शहरी नियोजन विभाग,

उत्तर प्रदेश शासन।

कल्याण नियोजन प्रकौष्ठ

समाल कल्याण विभाग

विषय: रिट याचिका सं०- 324/2020 श० बलराम सिंह बनाम यूनियन ऑफ इंजिनियर्स एवं अन्य सं० मा० उत्तर प्रदेश द्वारा पारित आदेश दिनांक 20-10-

2023 के क्रियान्वयन के संबंध में।

महोदय,

कृपया रिट याचिका संख्या- 583/2003 सफाई कर्मचारी आन्दोलन बनाम

यूनियन ऑफ इंजिनियर्स एवं अन्य सं० मा० उत्तर प्रदेश द्वारा पारित आदेश दिनांक

27-03-2014 के क्रियान्वयन के संबंध में कल्याण नियोजन प्रकौष्ठ, समाल कल्याण

विभाग के शासनादेश संख्या-540/क०नि०प्र०/26-3-2014-5(94)/2005 दिनांक 09

सितम्बर, 2014 का संदर्भ ग्रहण करने का कष्ट करें।

2- अद्यतन कराना है कि रिट याचिका सं०-324/2020 श० बलराम सिंह बनाम

यूनियन ऑफ इंजिनियर्स एवं अन्य सं० मा० उत्तर प्रदेश नई दिल्ली द्वारा पारित

आदेश दिनांक 20-10-2023 (प्रतिनिधि संगठन) में दिये गये निर्देशों में सीवर/ सैनिटरी

टैंक की घातक सफाई में मृत मनुजब स्कैवर्स के शोषित परिजन/विकलांग हों

10/12/2023

मैनुअल स्कैवेजर को मुआवजा दिये जाने के संबंध में बिन्दु संख्या-96 के (4) एवं (5) के अन्तर्गत निम्नलिखित निर्देश दिये गये हैं:-

96-

“.....

(4) The Court hereby directs the Union and the States to ensure that the compensation for sewer death is increased (given that the previous amount fixed i.e. ₹10 lakhs) was made applicable from .1993 The current equivalent of that amount is ₹30 lakhs. This shall be the amount to be paid, by the concerned agency i.e. the Union, the Union Territory or the State as the case may be. In other words, compensation for sewer deaths shall be ₹30 lakhs. In the event, dependents of any victims have not paid such amount, the above amount shall be payable to them. Furthermore, this shall be the amount to be hereafter paid, as compensation.

(5) Likewise, in the case of sewer victims suffering disabilities, depending upon the severity of disabilities, compensation shall be disbursed. However, the minimum compensation shall not be less than ₹10 lakhs. If the disability is permanent, and renders the victim economically helpless, the compensation shall not be less than ₹ 20 lakhs.....”

3- मा0 उच्चतम् न्यायालय द्वारा पारित उपरोक्त निर्णय के परिप्रेक्ष्य में न्याय विभाग द्वारा दिये गये बहुमूल्य परामर्श के अनुसार मा0 उच्चतम् न्यायालय द्वारा पारित आदेश /निर्देश विधि अनुसार बाध्यकारी हैं। सीवर/सैफ्टिक टैंक की सफाई के दौरान होने वाली व्यक्ति की मृत्यु के संबंध में कर्मचारी के आश्रित परिवार को क्षतिपूर्ति हेतु संबंधित नियोक्ता/ नियोजक उत्तरदायी होंगे।

4- अतः इस संबंध में मुझे यह कहने का निदेश हुआ है कि कृपया प्रश्नगत रिट याचिका संख्या-324/2020 डा0 बलराम सिंह बनाम यूनियन आफ इण्डिया एवं अन्य में मा0 उच्चतम् न्यायालय द्वारा दिनांक 20-10-2023 को पारित उपरोक्त निर्णय/निर्देशों का पूर्ण रूप से अनुपालन सुनिश्चित कराने का कष्ट करें।
संलग्नक: यथोक्त।

//True copy//

भवदीय,

209

Digitally Signed by हरिओम
Date: 21/10/2023 17:37
Reason: मुआवजा

//True copy//

210

संयुक्त सचिव।
(नन्द किशोर शर्मा)

आजा से,

9. गाई फाड़ल।
8. समस्त जिला समाज कल्याण अधिकांसी(विकास), उत्तर प्रदेश।
7. प्रबन्ध निदेशक, उ०प्र०अनुसूचित जाति विद्या एवं विकास निगम लि०, महानगर, लखनऊ।
6. समस्त जिला अधिकांसी, उत्तर प्रदेश।
5. निदेशक, पंचायतीरज विभाग, उत्तर प्रदेश, लखनऊ।
4. निदेशक, राष्ट्रीय विकास, उत्तर प्रदेश, लखनऊ।
3. निदेशक, समाज कल्याण, उत्तर प्रदेश, लखनऊ।
- नई दिल्ली।
2. संयुक्त सचिव, सामाजिक न्याय और अधिकारिता मंत्रालय, भारत सरकार शास्त्री भवन, दिल्ली।
1. सचिव, सामाजिक न्याय और अधिकारिता मंत्रालय, भारत सरकार, शास्त्री भवन नई दिल्ली।

प्रतिलिपि निम्नलिखित को सूचनाएं एवं आवश्यक कार्यवाही हेतु प्रेषित:-

संख्या- (1)/क०नि०प्र०/26-3-2023 तदिनांक

सं. 6001

REGD. NO. D. L. 11004/99



भारत का राजपत्र

The Gazette of India

असाधारण
 EXTRAORDINARY
 भाग II—खण्ड 3—उप-खण्ड (1)
 PART II—Section 3—Sub-section (1)
 प्राधिकार से प्रकाशित
 PUBLISHED BY AUTHORITY

सं. 6001 नई दिल्ली, बुधवार, दिसम्बर 12, 2013/अग्रहायण 21, 1935
 No. 6001 NEW DELHI, THURSDAY, DECEMBER 12, 2013/AGRAHAYANA 21, 1935

साप्ताहिक न्याय और अधिकारिता मंत्रालय
 (साप्ताहिक न्याय और अधिकारिता विभाग)
 अधिनियम

नई दिल्ली, 12 दिसम्बर, 2013

सं. 778(अ).—केंद्रीय सरकार हाथ से मीता उठाने वाले कर्मियों के नियोजन का प्रतिषेध और उनका पुनर्वास अधिनियम, 2013 (2013 का 25) की धारा 37 की उपधारा (1) के छ: (क) के साथ पठित धारा 36 की उप-धारा (1) और उप-धारा (2) द्वारा प्रदत्त शक्तियों का प्रयोग करते हुए निम्नलिखित नियम बनाती है, अर्थात् :-

अध्याय 1
 साधारण

1. संक्षिप्त नाम और प्रारंभ :-

(1) इन नियमों का संक्षिप्त नाम हाथ से मीता उठाने वाले कर्मियों के नियोजन का प्रतिषेध और उनका पुनर्वास विनियम, 2013 है।

(2) ये राजपत्र में प्रकाशन की शर्तों को पूरा होंगे।

2. शीर्षक :- (1) इन नियमों में, जब तक कि संदर्भ से अन्यथा अपेक्षित न हो-

(क) "अधिनियम" से हाथ से मीता उठाने वाले कर्मियों के नियोजन का प्रतिषेध और उनका पुनर्वास अधिनियम, 2013 (2013 का 25) अभिप्रेत है।

(ख) "उपरोक्त" व्यक्ति नियम 5 में निर्दिष्ट उपरकर्तों को सीमित न करते हुए जिसके अंतर्गत हाथ से या यंत्रिक रूप से प्रचलित किन्तु पलायन :-

- (1) वह जाती या उस विभाग में जो कि सेक्टर के परिवहन या प्रवाह को साफ करने का कार्य बनाने के लिए और
- (2) ऐसी जाति या वर्ग के साथ जो कि वर्गों के संदर्भ को बनाने के लिए उपयोग किए जा सकते हैं।
- (3) "नियम" और "अधिनियम" से निम्नलिखित संदर्भों के साथ नियम 11(2), नियम 11(18) और नियम 11(19) में निर्दिष्ट शक्ति अभिप्रेत है :-

5287 03/2013

212

(110)

True copy

आते हैं :

विमान कुटी में प्रवेश करने के दौरान कोई भी व्यक्ति अवस्था (वीस, डबल या थ्रीस) में मल या कोई अन्य सामग्री के संपर्क में को काम करने के लिए सभी आवश्यक उपकरण भी है जो मल वाली या मल विमान कुटी के भीतर और जहाँ मल वाली या मल विमान कुटी की सफाई में लगे हुए व्यक्तियों द्वारा रोकथाम और सफाई के संपर्क को दूर करने की गणना व्यक्तियों के अतिरिक्त "सूक्ष्म पूर्ववर्णनियों" से निवृत्त पूर्ववर्णनियों को सीमित 4 वर्षों के लिए निम्नलिखित अर्थान्त मल वाली और

कोई व्यक्ति अधिनियम है :

(ख) "सफाई कार्यवाही" या "स्वच्छता कार्यक्रम" से छूट कर "सफाई कार्य" से छूट कर "सफाई कार्य" के लिए नग्न नग्न या निर्वासित कोई व्यक्ति अधिनियम है :

(ii) धारि को दूर करना जब सफाई कार्य किया जा रहा हो ।

मल विमान कुटी के अंदर उपस्थित गैसों की परमाणु के लिए कोई सखी उपकरण भी है :

(1) पराधी को मान्य तथा को संपर्क से बचाने के लिए जो किसी चीज का कारण हो सकता है जिसके साथ सखी स्वयं उपकरण जिसकी अंतःस्वयं से चीज का संपर्क हो सकता है, और जिसके अंतर्गत मल वाली को

नाश है -

(ख) "संज्ञानात्मक सफाई" से अतिरिक्त सूक्ष्म उपकरण और सूक्ष्म पूर्ववर्णनियों अधिनियम है जो मल वाली और मल विमान कुटी को सफाई के संबंध में सफाई कार्यवाही या सफाई कार्यवाही द्वारा प्रवेश के लिए या उपकरण के लिए उपकरण कागज आदि को कार्य की विधि प्रकृति को करने के लिए आवश्यक ठीक जिसके अंतर्गत विमान 4 में निर्दिष्ट सामग्री को सीमित नहीं किया

(घ) "अधिवसित" से छूट विमानों के अतिरिक्त सफाई के प्रयोग या कर्मियों के निर्देश को स्वयं उपकरण द्वारा निर्वासित कोई अधिकारी अधिनियम है :

(ङ) "निरीक्षण" से अधिनियम की धारा 20 की उपधारा (1) के उपधारा के अनुसार सूक्ष्म स्वयं उपकरण द्वारा निर्वासित से विमान कोई व्यक्ति अधिनियम है :

(च) "प्राणिक" से छूट से मल उतारने वाले कर्मियों को अतिरिक्त सफाई के प्रयोग के लिए जिसकी स्वयं उपकरण द्वारा निर्वासित निर्वासित कोई व्यक्ति अधिनियम है :

घ. बिना से छूट से मल उतारने वाले कर्मियों को अतिरिक्त सफाई के प्रयोग के लिए ।

क. बिना से छूट से मल उतारने वाले कर्मियों को अतिरिक्त सफाई के प्रयोग के लिए ।

ख. अतिरिक्त सफाई पर आवश्यकता अधिनियम के लिए सामग्री निर्वासित करना ।

ग. अतिरिक्त सफाई पर आवश्यकता अधिनियम के लिए सामग्री निर्वासित करना ।

घ. बिना कर पर संश्लेषण विधि की सफाई और सफाई करना ।

विमान कर पर संश्लेषण सफाई के प्रयोग :

द्वारा सफाई के रूप में

1. विमान सफाई
2. उपस्थित सभी सफाई को मजदूर करने वाले विमान सफाई के प्रयोग के लिए सामग्री अधिनियम
3. विमान सफाई अधिनियम
4. मल विमान सफाई/स्वच्छता अधिनियम
5. मल विमान सफाई अधिनियम
6. मल से मल उतारने वाले कर्मियों को अतिरिक्त सफाई के प्रयोग के लिए सामग्री अधिनियम
7. अतिरिक्त सफाई के प्रयोग के लिए सामग्री अधिनियम
8. अतिरिक्त सफाई के प्रयोग के लिए सामग्री अधिनियम
9. अतिरिक्त सफाई के प्रयोग के लिए सामग्री अधिनियम
10. अतिरिक्त सफाई के प्रयोग के लिए सामग्री अधिनियम

(PART II - Sec. 20)

THE GAZETTE OF INDIA: EXTRAORDINARY

True copy

214 (53)

आरक्षण संख्या: 1761/कॉम-26-2-2014-13(60)-2013

वै किंगु एण्ड से का एगिजिड काय से प्रकृति से उरकर है वा
 (क) "संसाधन" को अर्थगत विभाग 6 से विहित प्रकृति से उरकर है वा
 (ख) "संसाधन" का अर्थगत विभाग 6 से अर्थगत प्रकृति से उरकर है वा
 (ग) "संसाधन" का अर्थगत विभाग 6 से अर्थगत प्रकृति से उरकर है वा

1-(1) यह विधायकी काय से अर्थगत प्रकृति से उरकर है वा
 (2) यह प्रकृति से उरकर है वा
 उरकर प्रकृति विधायकी, 2014 से अर्थगत है।

एण्ड से अर्थगत प्रकृति से उरकर है वा
 (क) "संसाधन" का अर्थगत विभाग 6 से अर्थगत प्रकृति से उरकर है वा
 (ख) "संसाधन" का अर्थगत विभाग 6 से अर्थगत प्रकृति से उरकर है वा

अर्थगत विभाग

आरक्षण संख्या: 1761/कॉम-26-2-2014-13(60)-2013

उरकर प्रकृति विभाग

आरक्षण संख्या: 1761/कॉम-26-2-2014-13(60)-2013

उरकर प्रकृति विभाग

अर्थगत विभाग

उरकर प्रकृति विभाग

संसाधन विभाग, उरकर प्रकृति

आरक्षण संख्या: 1761/कॉम-26-2-2014-13(60)-2013
 आरक्षण संख्या: 1761/कॉम-26-2-2014-13(60)-2013
 आरक्षण संख्या: 1761/कॉम-26-2-2014-13(60)-2013



आरक्षण संख्या: 1761/कॉम-26-2-2014-13(60)-2013

उपपर प्रदेश असाधारण गजट, 11 दिसम्बर, 2014

(1) मूल माली या मूल निगलतन सुधी से रोस्टेज के परिचयक या माली को सहायक करने या सहायक बनाने के लिए, और
(ii) ऐसी मूल या सामग्री के साथ सीधे हाथों के सम्पर्क को रोकने के लिए उपरोक्त किये जा सकें।

लिए उपरोक्त मूल सहायक एजेंसि को सहायक निम्नलिखित सार्वजनिक क्षेत्रों के रूप- निगम (7), (10) और (19) में निर्दिष्ट समिति से है :-

विषय-11

1. जिला मजिस्ट्रेट
2. उपर जिला विभागा अधिकारी (समान सहायक) एक सदस्य/सदस्य बंदेस जिला प्रबंधक, U.P. अनुसूचित जाति तथा शिवा एवं शिक्षण विभाग.

3. जिला सांख्यिकीय अधिकारी
4. संरक्षक अधिकारी, जिला नगरीय विकास प्राधिकरण
6. स्थानीय विकास का जिला स्तर का प्रांतीय अधिकारी
5. जिला पंचायतीराज अधिकारी
7. रेल प्राधिकरण का एक प्रतिनिधि
8. हाथ से मिला उठाने वाले कर्मियों और सफाई कर्मचारियों के कल्याण के लिए कार्यरत मूल संरक्षक संगठनों के अधिकारण दो प्रतिनिधि जो जिला मजिस्ट्रेट द्वारा नामनिर्दिष्ट होंगे
9. अधिकारण दो सामुदायिक प्रतिनिधि जिनमें से एक महिला होगी जो जिला मजिस्ट्रेट द्वारा नामनिर्दिष्ट होंगे।

जिला स्तर सर्वसाधारण समिति के छह सदस्य जिला स्तर पर सर्वसाधारण समिति को मानीटर और संवेक्षण करना, एवं अभिहित स्थानों पर जागरूकता अभियान के लिए सामग्री वितरित करना, म. सर्वसाधारण के सम्पर्क में स्थानीय समाचार पत्र आदि के माध्यम से प्रचार को व्यवस्था करना;

घ. अपनी अधिकारिता के अधीन अधिहित स्थानों पर अनुचित सर्वसाधारण शायद वितरित करना;
 छ. जिले के सभी शहर, नगरों और ग्रामों के लिये हाथ से मिला उठाने वाले कर्मियों की अन्तिम सूची को अनुमोदित करना;
 घ. जिले में हाथ से मिला उठाने वाले कर्मियों की अन्तिम समेकित सूची को प्रकाशित करना।

(ग) 'प्रायक' का तात्पर्य हाथ से मिला उठाने वाले कर्मियों के सर्वसाधारण या सहायक के प्रयोजन के लिए किसी स्थानीय प्राधिकरण द्वारा नियोजित कोई व्यक्ति से है;

(घ) 'निरीक्षक' का तात्पर्य अभिनियम की धारा 20 की उपधारा (i) के उपबन्ध के अनुसार तत्व संरक्षक द्वारा 'निरीक्षक' के रूप में नियुक्त कोई व्यक्ति से है;

(ग) 'ओवरसियर' का तात्पर्य इन नियमों के अधीन शक्तियों के प्रयोग या कर्तव्यों के निर्वाहन को स्थानीय प्राधिकरण द्वारा नियोजित कोई अधिकारी से है;

(घ) 'संरक्षक सचिवों' का तात्पर्य व्यक्तिगत सुरक्षा उपकरण और सुरक्षा शक्तियों से है जो मूल माली और मूल निगलतन कुंड़ों की सफाई के संबंध में सर्वसाधारण कर्मचारियों या सफाई कर्मचारियों द्वारा पहनने के लिए या उपयोग के लिये उपलब्ध कराए जाते हैं जो कार्य की विशिष्ट प्रकृति को करने के लिए आवश्यक होंगे जिसके अन्तर्गत नियम 4 में निर्दिष्ट सामग्री को सीमित नहीं किया गया है:-

(i) पदार्थों को मूल माली के सम्पर्क से बचाने के लिए जो किसी रूप का कारण हो सकती है जिसके साथ सभी संयोजन उपकरण वितरित नहीं के अन्तर्गत मूल माली या मूल निगलतन कुंड़ों के अन्तर उपस्थित माली को पहनाने के लिए कोई संवेक्षी उपकरण की है;

(ii) हाथों को दूर करना जब सफाई कार्य किया जा रहा हो।

True copy

215

(54)

सरकारी गजट, उत्तर प्रदेश

उत्तर प्रदेशीय सरकार द्वारा प्रकाशित

असाधारण

विधायी परिशिष्ट

भाग-4, खण्ड (ख)

(परिनियत आदेश)

लखनऊ, बुधवार, 21 मई, 2014

वैशाख 31, 1936 शक सम्वत्

UTTAR PRADESH SHASAN

SAMAJ KALYAN VIBHAG

Kalyan Niyojan Prakosth

पृष्ठ-149

In pursuance of the provisions of clause (3) of Article 348 of the Constitution, the Governor is pleased to order the publication of the following English translation of notification no. 106/KNP-XXVI-3-2014-13(60)-2013, dated May 21, 2014:

NOTIFICATION

No. 106/KNP-XXVI-3-2014-13(60)-2013

Dated Lucknow, May 21, 2014

IN exercise of the powers conferred by sub-section (1) of section 26 of the Prohibition of Employment as Manual Scavengers and their Rehabilitation Act, 2013 (Act no. 25 of 2013), the Governor is pleased to constitute the State Monitoring Committee consisting of the following members:—

A. In pursuance of clauses (a) to (d) of sub-section (1) of section 26 of the Act-

- | | |
|-----------------------------------------------------------------|------------------------|
| (a) The Minister for Social Welfare Department | Chairperson ex-officio |
| (b) Chairperson, State Commission for Safai Karamcharis | Member ex-officio |
| (c) Chairperson, State Commission for Scheduled Castes | Member ex-officio |
| (d) Representative of National Commission for Scheduled Castes | Member ex-officio |
| (e) Representative of National Commission for Safai Karamcharis | Member ex-officio |

B. In pursuance of clause (e) of sub-section (1) of section 26 of the Act-

- | | |
|-------------------------------------------|-------------------|
| (i) Smt. Madhu Bala Pasi (State Assembly) | Member ex-officio |
| (ii) Smt. Asha Kishor (State Assembly) | Member ex-officio |

00 RPH data 8

//True copy//

(132)

217

C. Director General of Police, Uttar Pradesh	Member ex-officio
D. Principal Secretaries of the following Departments -	
(i) Home	Member ex-officio
(ii) Panchayatiraj	Member ex-officio
(iii) Urban Development	Member ex-officio
(iv) Finance	Member ex-officio
(v) Housing Development	Member ex-officio
(vi) Nagriya Rojgar Evam Gajibi Unmulan Karyakram	Member ex-officio
(vii) Rural Development	Member ex-officio
(viii) Vocational Education and Skill Development	Member ex-officio
E. In pursuance of clause (h) of sub-section (1) of section 26 of the Act-	
(i) Mukhya Nagar Ayukt, Municipal Corporation, Lucknow	Member ex-officio
(ii) District Panchayatiraj Adhikari, Lucknow	Member ex-officio
(iii) Chief Executive Officer, Cantonment Board, Lucknow	Member ex-officio
(iv) Representative of Railway to be nominated by Chairman Railway Board	Member ex-officio
F. In pursuance of clause (i) of sub-section (1) of section 26 of the Act-	
(i) Sri Krishna Gopal Balmiki, S/o Sri Kundan Lal, Bari Chhlauli, Balmiki Basti, Post-Kayamganj, District-Farrukhabad, Pin-207502	
(ii) Sri Shailendra Balmiki, S/o Sri Jai Kumar, Anamika Road, Gulab Nagar, Tundala, District-Ferozabad.	
G. State level Head of the Covener Bank of State Level Bankers' Committee	Member ex-officio
H. Principal Secretary, Social Welfare Department	Member Secretary ex-officio
I. In pursuance of clause (j) of sub-section (1) of section 26 of the Act-	
(i) Director, Panchayatiraj Department, Uttar Pradesh	Member ex-officio
(ii) Director, Local Bodies, Uttar Pradesh	Member ex-officio
(iii) Director, State Urban Development Authority, Uttar Pradesh	Member ex-officio
(iv) Director, Social Welfare Department, Uttar Pradesh	Member ex-officio
(v) Managing Director, Uttar Pradesh Scheduled Castes Finance and Development Corporation	Member ex-officio

2. (i) The term of office of the members of State Assembly who are nominated under para B shall be co-terminus with their membership in the respective House of State Assembly.

(ii) The term of office of the social workers who are nominated under para F shall be for a period of three years from the date of publication of this notification.

By order,
SUNIL KUMAR,
Pramukh Sachiv.

पी०एस०यू०पी०-ए०पी० 100 राजपत्र (हि०)-2014-(248)-599 प्रतियां (कम्प्यूटर/टी०/आफसेट)
पी०एस०यू०पी०-ए०पी० 1 स० समाज कल्याण-2014-(247)-500 प्रतियां (कम्प्यूटर/टी०/आफसेट)

//True copy//

100 RPH data 8

(133)

218

क्रम संख्या-110(क-6)



संविधान संख्या-110(क-6)

संख्या/संख्या-110/2013-14

संविधान संख्या-110(क-6)

सरकारी गजट, उत्तर प्रदेश

उत्तर प्रदेशीय सरकार द्वारा प्रकाशित

असाधारण

विधायी परिशिष्ट

भाग-4, खण्ड (ख)

(परिनियत आदेश)

लखनऊ, बुधवार, 28 मई, 2014

खंड 7, 1936 शक संवत्

UTTAR PRADESH SIHARAN

SAMAJ KALYAN VIDHAN

Kalyan Niyojan Prakosth

पृष्ठ-152

In pursuance of the provisions of clause (3) of Article 348 of the Constitution, the Governor is pleased to order the publication of the following English translation of notification no. 689/KNP-XXVI-3-2014-13(60)-2013, dated May 28, 2014:

NOTIFICATION

No. 689/KNP-XXVI-3-2014-13(60)-2013

Dated Lucknow, May 28, 2014

In exercise of the powers conferred by sub-sections (1) and (2) of section 24 of the Prohibition of Employment as Manual Scavengers and their Rehabilitation Act, 2013 (Act no. 25 of 2013), the Governor is pleased to constitute the District Vigilance Committee for each district consisting of the following members :-

(a) the District Magistrate

Choirperson
ex-officio

(b) all members of the State Legislature belonging to the Scheduled Castes elected from the district:

Members

Provided that if a district has no member of the State Legislature belonging to the Scheduled Castes, the District Magistrate may nominate such number of other members of the State Legislature from the district, not exceeding two, as he may deem appropriate

//True copy//

उत्तर प्रदेश अधिनियम नं. 28 का. 2014

- (c) the District Superintendent of Police *Member ex-officio*
- (d) the Chief Executive Officer of the Panchayat at the district level *Member ex-officio*
- (e) the Chief Executive Officer of the Municipality at the district headquarter *Member ex-officio*
- (f) the Chief Executive Officer of any other Municipal Corporation constituted in the district *Member ex-officio*
- (g) the Chief Executive Officer of Cantonment Board, if any, situated in the district *Member ex-officio*
- (h) one representative to be nominated by the railway authority located in the district *Member*
- (i) not more than four social workers belonging to the organisation working for the prohibition of manual scavenging and rehabilitation of the manual scavengers, or, representing the scavenger community, resident in the district, to be nominated by the District Magistrate, two of whom shall be women *Members*
- (j) one person to represent the financial and credit institutions in the district, to be nominated by the District Magistrate *Member*
- (k) Additional District Development Officer (Social Welfare) *ex-officio* District Manager, Uttar Pradesh Scheduled Castes Finance and Development Corporation *Member-Secretary ex-officio*
- (l) District level officers of the Departments and agencies who, in the opinion of the District Magistrate, subject to the general orders, if any, of the State Government, have a significant role to play in the implementation of this Act, to be nominated by the District Magistrate. *Members*

2. (i) The term of office of the members of State Legislature who are nominated under clause (b) above shall be co-terminus with their membership in the respective House of the State Legislature.
- (ii) The term of office of the social workers who are nominated under clause (i) above shall be for a period of three years from the date of publication of this notification in the *Gazette*.

By order,
SUNIL KUMAR,
Pramukh Sochiv.

पी०एस०यू०पी०-ए०पी० 103 राजपत्र (हि०)-2014-(252)-599 प्रतियां (कम्प्यूटर/ई०/ऑफसेट)।
पी०एस०यू०पी०-ए०पी० 4 स० समाज कल्याण-2014-(253)-500 प्रतियां (कम्प्यूटर/ई०/ऑफसेट)।

103 RPH का 8

//True copy//

(135) 220

१२३४५६७८९०



उत्तर प्रदेश सरकार
मुख्यालय, लखनऊ

प्रदेशीय, उत्तर प्रदेश

उत्तर प्रदेश सरकार द्वारा जारी

अज्ञापन

आदेश (२०१४)

(२०१४)

दिनांक: २० मई, २०१४

२०१४

UTTAR PRADESH SHASAN

SAMAI KAI VAN VINDHAI

Kajvan Nigvan Prakash

१२३४-१२०

In pursuance of the provisions of clause (3) of Article 148 of the Constitution, the Governor is pleased to order the publication of the following English translation of notification no. 690/KMP-XXVI-3-2014-13(60).

2012, dated May 28, 2014.

NOTIFICATION

No. 690/KMP/XXVI-3-2014-13(60)-2013

Dated Lucknow, May 28, 2014

In exercise of the powers conferred by sub-sections (1) and (2) of section 24 of the Prohibition of Employment as Manual Scavengers and their Rehabilitation Act, 2013 (Act no. 25 of 2013), the Governor is pleased to constitute the Sub-Divisional Level Vigilance Committee consisting of the following members -

(a) the Sub-Divisional Magistrate

(b) the Chairpersons and the Chief Executive Officers of Panchayats at intermediate level of the Sub-Division, and where Panchayats at intermediate level do not exist, Chairpersons from two Panchayats at Village level to be nominated by the Sub-Divisional Magistrate

(c) the Sub-Divisional Officer of Police

(d) the Chief Executive Officer of the Municipality of the Sub-Divisional headquarters

Sub-Division

(f) one representative to be nominated by the railway authority located in the Sub-Division

Members ex-officio

Members ex-officio

Members ex-officio

Members ex-officio

Members ex-officio

Chairperson ex-officio

// True copy //

221

(1267)

for RPH (Sample) 2014 Date: ?

3711 वी वारीय मस. 28 दि. 2014

(8) two social workers belonging to the organization working for the provision of manual scavenging and rehabilitation of the manual scavengers, or, representing the scavenger community, resident in the Sub-Division, to be nominated by the Sub-Divisional Magistrate, one of whom shall be woman

Members

(i) an Assistant Development Officer (Social Welfare) of the Block Development situated in the Sub-Divisional Headquarters

Member-Secretary

Member

(j) District level officers of the Departments and agencies who, in the opinion of the District Magistrate, subject to the general orders, if any, of the State Government, have a significant role to play in the implementation of this Act, to be nominated by the Sub-Divisional Magistrate

ex-officio

Members

2. The term of office of the social workers who are nominated under clause (8) above shall be for a period of three years from the date of publication of this notification in the Gazette.

By order,
SUNIL KUMAR,
Pranulch Sachiv.

True copy!!!

(137) 222

(1) Ref (Samad) 2012 Dm-1

प्रमाणित प्रतिलिपि (2) - 2014 - (248) - 3000 प्रतिलिपि (मार्ग/210/प्रमाणित)।
प्रमाणित प्रतिलिपि (2) - 2014 - (248) - 3000 प्रतिलिपि (मार्ग/210/प्रमाणित)।

प्र.सं.सं-116 (अ)



उत्तर प्रदेश सरकार
समाज कल्याण विभाग
कलकत्ता नगर, उत्तर प्रदेश

भारतीय गणतंत्र, उत्तर प्रदेश

उत्तर प्रदेशीय सरकार द्वारा प्रकाशित

अभिसूचना

भारतीय गणतंत्र

सं. 354-क.न.प./XXVI-3-2014-15(60)-2013

(प्रतिभा संख्या)

दिल्ली, भारत, 3 जून, 2014

दिनांक 13.06.2014

UTTAR PRADESH SHASAN

SAMAJ KALYAN VIBHAG

Kalkatta Nagar, Uttar Pradesh

NOTIFICATION

90310-176

In pursuance of the provisions of clause (3) of Article 348 of the Constitution, the Governor is pleased to order the publication of the following English translation of notification no. 354-K.N.P./XXVI-3-2014-15(60)-2013, dated June 3, 2014:

No. 354-K.N.P./XXVI-3-2014-15(60)-2013

Dated Lucknow, June 3, 2014

In exercise of the powers conferred by sub-section (1) of section 32 of the Prohibition of Employment as Manual Scavengers and their Rehabilitation Act, 2013 (Act no. 25 of 2013), the Governor is pleased to designate the Uttar Pradesh State Commission for Safai Karamcharis to perform, within the State of Uttar Pradesh, the functions specified in sub-section (1) of section 31 of the said Act.

By order
SUNIL KUMAR,
Pravasi Sakhiv.

True copy!!!

223

(139)

प्रेषक,

बृजेश कुमार संत,
सचिव,
उत्तराखण्ड शासन।

सेवा में,

सचिव,
सामाजिक न्याय एवं अधिकारिता मंत्रालय,
भारत सरकार, नई दिल्ली।

समाज कल्याण अनुभाग-03

देहरादून, दिनांक 08 जनवरी, 2024

विषय-मा0 उच्चतम न्यायालय, नई दिल्ली में योजित रिट पिटीशन (सिविल)

संख्या-324/2020 डा0 बलराम सिंह बनाम भारत संघ व अन्य के सम्बन्ध में।

महोदय,

कृपया उपर्युक्त विषयक आपके कार्यालय के पत्र संख्या-U-12012/01/2023-(PLAN) दिनांक 15.12.2023 का सन्दर्भ ग्रहण करने का कष्ट करें, जिसके माध्यम से मा0 उच्चतम न्यायालय, नई दिल्ली में योजित रिट पिटीशन (सिविल) संख्या-324/2020 डा0 बलराम सिंह बनाम भारत संघ व अन्य में मा0 उच्चतम न्यायालय द्वारा दिनांक 20.10.2023 को प्रदत्त आदेश के प्रस्तर-96 के अनुसार 14 बिन्दुओं पर अनुपालन आख्या उपलब्ध कराये जाने की अपेक्षा की गयी है।

2. इस सम्बन्ध में अवगत कराना है कि मा0 न्यायालय द्वारा दिये गये उक्त आदेश के प्रस्तर-96 के अनुसार 14 बिन्दुओं में से बिन्दु संख्या-01, 07, 08, 09, 11 व 13 भारत सरकार से सम्बन्धित है एवं राज्य सरकार से सम्बन्धित बिन्दु संख्या-02, 03, 04, 05, 06, 10, 12 एवं 14 की बिन्दुवार अनुपालन आख्या निम्नवत् है :-

Point no. 2 All States and Union Territories are likewise, directed to ensure that all departments, agencies, corporations and other agencies (by whatever name called) ensure that guidelines and directions framed by the Union are embodied in their own guidelines and directions; the states are specifically directed to ensure that such directions are applicable to all municipalities, and local bodies functioning within their territories;

Action Taken/Status :- भारत सरकार द्वारा निर्गत दिशा-निर्देशों एवं अधिनियमों के अनुसार अग्रेत्तर कार्यवाही सम्पादित कर दी गयी है। केवल The Prohibition of Employment as Manual Scavengers and their Rehabilitation Act, 2013 की धारा 21 (Confer Powers of judicial Magistrate of First Class, on an Executive Magistrate, For the Trial of offences under the Act) के अन्तर्गत Executive Magistrate को judicial Magistrate की शक्तियां प्रदान किये जाने के सम्बन्ध में परामर्श प्रदान किये जाने हेतु मा0 उत्तराखण्ड उच्च न्यायालय से अनुरोध किया गया है।

Point no. 3 The Union, State and Union Territories are directed to ensure that full rehabilitation (including employment to the next of kin, education to the wards, and skill training) measures are taken in respect of sewage workers, and those who die;

Action Taken/Status :- राज्य सरकार द्वारा सीवर/सैप्टिक टैंक की सफाई में मृत स्थाई सफाई कर्मचारियों के आश्रितों को उत्तराखण्ड सरकारी सेवक के मृतक आश्रित को सेवायोजन नियमावली के अनुसार सेवायोजित किया जाता है।

सफाई कर्मचारियों के आश्रितों को भारत सरकार द्वारा संचालित अनुसूचित जाति पूर्व दशम छात्रवृत्ति योजना के अन्तर्गत छात्रवृत्ति प्रदान की जा रही है।

समाज कल्याण विभाग के अन्तर्गत संचालित उत्तराखण्ड बहुउद्देशीय वित्त एवं विकास निगम द्वारा सफाई कर्मचारियों व उनके आश्रितों के कौशल विकास हेतु विभिन्न व्यवसायों में प्रशिक्षण प्रदान किये जाने हेतु योजनायें संचालित की जा रही है। (विवरण संलग्न)

Point no. 4 The court hereby directs the Union and the States to ensure that the compensation for sewer deaths is increased (given that the previous amount fixed, i.e., 10 lakhs) was made applicable from 1993. The current equivalent ₹ of that amount is Rs. 30 lakhs. This shall be the amount to be paid, by the concerned agency, i.e., the Union, the Union Territory or the State as the case may be. In other words, compensation for sewer deaths shall be 30 lakhs. In ₹ the event, dependents of any victim have not been paid such amount, the above amount shall be payable to them. Furthermore, this shall be the amount to be hereafter paid, as compensation.

Action Taken/Status :- समाज कल्याण विभाग के शासनादेश संख्या-04 दिनांक 04.01.2024 (छायाप्रति संलग्न) के द्वारा सीवर/सैप्टिक टैंक की सफाई में मृत सफाई कर्मचारियों के आश्रित परिजनों को क्षतिपूर्ति के रूप में ₹30.00 लाख की धनराशि प्रदान किये जाने हेतु उनके नियोक्ता विभागों को निर्देशित कर दिया गया है।

Point no. 5 Likewise, in the case of sewer victims suffering disabilities, depending upon the severity of disabilities, compensation shall be disbursed. However, the minimum compensation shall not be less than 10 lakhs. If the disability is ₹ permanent, and renders the victim economically helpless, the compensation shall not be less than 20 lakhs.

Action Taken/Status :- समाज कल्याण विभाग के शासनादेश संख्या-04 दिनांक 04.01.2024 (छायाप्रति संलग्न) के द्वारा सीवर/सैप्टिक टैंक की सफाई के दौरान सफाई कर्मचारी के दिव्यांगता की स्थिति में न्यूनतम ₹10.00 लाख एवं स्थायी रूप से दिव्यांग हुये सफाई कर्मचारियों को न्यूनतम ₹20.00 लाख की क्षतिपूर्ति की धनराशि प्रदान किये जाने हेतु उनके नियोक्ता विभागों को निर्देशित कर दिया गया है।

//True copy//

क्रमशः.....3

225

114900 01/11/24

Point no.6 The appropriate government (i.e., the Union, State or Union Territories) shall devise a suitable mechanism to ensure accountability, especially wherever sewer deaths occur in the course of contractual or "outsourced" work. This deaths occur in the course of contractual or "outsourced" work. This accountability shall be in the form of cancellation of contract, forthwith, and imposition of monetary liability, aimed at deterring the practice.

Action Taken/Status :- उक्त निर्देशों का अनुपालन किये जाने हेतु निदेशालय, शहरी विकास विभाग, उत्तराखण्ड के पत्र संख्या-3874 दिनांक 04.01.2024 (छायाप्रति संलग्न) द्वारा सभी स्थानीय निकायों को निर्देशित कर दिया गया है।

Point no.10 The Union, State and Union Territories are hereby required to set up scholarships to ensure that the dependents of sewer victims, (who have died, or might have suffered disabilities) are given meaningful education.

Action Taken/Status :- राज्य के अन्तर्गत अस्वच्छ पेशे में कार्यरत कर्मचारियों के आश्रितों को भारत सरकार द्वारा संचालित अनुसूचित जाति पूर्व दशम छात्रवृत्ति योजना के अन्तर्गत छात्रवृत्ति प्रदान की जा रही है।

सीवर/सैण्टिक टैंक की सफाई के दौरान मृत/दिव्यांग हुए सफाई कर्मचारियों के आश्रितों को दशमोत्तर छात्रवृत्ति प्रदान किये जाने हेतु योजना का प्रकरण नीतिगत होने के दृष्टिगत वर्तमान में विचारार्थीन है।

Point no.12 The Union, State and Union Territories are hereby directed to ensure coordination with all the commissions (NCSK, NCSC, NCST) for setting up of state level, district level committees and commissions, in a time bound manner. Furthermore, constant monitoring of the existence of vacancies and their filling up shall take place.

Action Taken/Status :- उत्तराखण्ड राज्य में राज्य आयोग, राज्य स्तरीय एवं जिला स्तरीय समितियों का गठन किया जा चुका है। उक्त संस्थाओं में रिक्तियों के सापेक्ष तैनाती की सतत निगरानी की जा रही है।

Point no.14 A portal and a dashboard, containing all relevant information, including the information relating to sewer deaths, and victims, and the status of compensation disbursement, as well as rehabilitation measures taken, and existing and available rehabilitation policies shall be developed and launched at an early date.

Action Taken/Status :- सीवर मृत्यु क्षतिपूर्ति की भुगतान की स्थिति व पुनर्वास से सम्बन्धित पोर्टल व डैशबोर्ड बनाये जाने हेतु ITDA के सहयोग से शहरी विकास विभाग, पेयजल विभाग, उत्तराखण्ड जल संस्थान एवं उत्तराखण्ड बहुउद्देशीय वित्त एवं विकास निगम के स्तर से कार्यवाही की जा रही है।

संलग्न-यथोक्त।

भवदीय,

True copy

(बुजेश कुमार सांत)

सचिव।

2226

संख्या- २-१ /XVII-A-3 / 2024-13(03) / 2023, तददिनांक।

प्रतिलिपि निम्न को प्रेषित:-

1. वरिष्ठ निजी सचिव-मुख्य सचिव, उत्तराखण्ड शासन को मुख्य सचिव महोदय के संज्ञानार्थ ।
2. अपर सचिव, शहरी विकास विभाग, उत्तराखण्ड शासन को सूचनार्थ एवं आवश्यक कार्यवाही हेतु।
3. अपर सचिव, पेयजल एवं स्वच्छता विभाग, उत्तराखण्ड शासन को सूचनार्थ एवं आवश्यक कार्यवाही हेतु।
4. अपर सचिव, पंचायती राज विभाग, उत्तराखण्ड शासन को सूचनार्थ एवं आवश्यक कार्यवाही हेतु।
5. अपर सचिव, आवास विभाग, उत्तराखण्ड शासन को सूचनार्थ एवं आवश्यक कार्यवाही हेतु।
6. प्रबन्ध निदेशक, उत्तराखण्ड बहुउद्देशीय वित्त एवं विकास निगम, देहरादून को सूचनार्थ एवं आवश्यक कार्यवाही हेतु।
7. निदेशक, समाज कल्याण उत्तराखण्ड हल्द्वानी-नैनीताल को सूचनार्थ एवं आवश्यक कार्यवाही हेतु।
8. गार्ड फाईल।

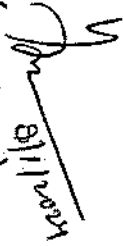
(प्रकाश चन्द्र)
अपर सचिव।

...
TRUE COPY!!

227

01(52)2014

प्रश्नक

शुभा कुमार शर्मा

राजिद

उत्तराखण्ड शासन

संघ में

2. प्रत्यक्ष निदेशक,
सिडकॉल, देहरादून।

राज्यी विकास विभाग/पंचायती राज विभाग/
औद्योगिक विकास विभाग/आवास विभाग/
पंचायत एवं स्वच्छता विभाग, उत्तराखण्ड शासन।

समाज कल्याण अनुभाग-03

देहरादून, दिनांक 04 जनवरी, 2024

विषय-मा10 उच्चतम न्यायालय में याचिका रिट याचिका (सिविल) संख्या-324/2020 जो10 बलराम सिंह बराम भारत एवं अन्य में मा10 उच्चतम न्यायालय द्वारा पारित आदेश दिनांक 20.10.2023 के सिद्धान्तों के संबंध में।

महोदय,

कृपया रिट याचिका संख्या-583/2003 संकाई कर्मचारी आन्दोलन बराम भारत संघ एवं अन्य में मा10 उच्चतम न्यायालय द्वारा पारित आदेश दिनांक 27.03.2014 के क्रम में सीवर/सेंटिक टैंक की सफाई में मुँल सफाई कर्मचारियों के आश्रित परिवार/विकलांग सफाई कर्मचारियों को ₹10.00 लाख की क्षतिपूर्ति प्रदान की जा रही है।

2. अगतन कराना है कि मा10 उच्चतम न्यायालय, नई दिल्ली में याचिका रिट याचिका (सिविल) संख्या-324/2020 जो10 बलराम सिंह बराम भारत संघ व अन्य में मा10 न्यायालय द्वारा पारित आदेश दिनांक 20.10.2023 (प्रतिनिधि संलग्न) में दिये गये निर्देशों में सीवर/सेंटिक टैंक की सफाई में मुँल सफाई कर्मचारियों के आश्रित परिवार/विकलांग सफाई कर्मचारियों को मुँलावना दिये जाने के सम्बन्ध में विन्सु संख्या-96 के प्रस्तर-04 एवं प्रस्तर-05 के अन्तर्गत निम्नलिखित निर्देश दिये गये हैं :-

(4) The court hereby directs the Union and the States to ensure that the compensation for sewer deaths is increased (given that the previous amount fixed, i.e., ₹10 lakhs) was made applicable from 1993. The current equivalent of that amount is ₹30 lakhs. This shall be the amount to be paid, by the concerned agency, i.e., the Union, the Union Territory or the State as the case may be. In other words, compensation for sewer deaths shall be ₹30 lakhs. In the event, depends of any victim have not been paid such amount, the above amount shall be payable to them. Furthermore, this shall be the amount to be here after paid, as compensation.

True copy
228

-2-

(5) Likewise, in the case of sewer victims suffering disabilities, depending upon the severity of disabilities, compensation shall be disbursed. However, the minimum compensation shall not be less than ₹10 lakhs. If the disability is permanent, and renders the victim economically helpless, the compensation shall not be less than ₹20 lakhs.

3. सीवर/सैण्टिक टैंक की सफाई के दौरान होने वाली मृत्यु के सम्बन्ध में सफाई कर्मचारी व आश्रित परिवार को क्षतिपूर्ति प्रदान किये जाने का उत्तरदायित्व सम्बन्धित नियोक्ता/नियोजक व होगा।

4. अतः इस सम्बन्ध में मुझे यह कहने का निदेश हुआ है कि प्रश्नगत रिट याचिका संख्या-324/2020 डा10 बलराम सिंह बनाम भारत संघ एवं अन्य में मा0 न्यायालय द्वारा दिनांक 20.10.2023 को पारित उपरोक्त निर्णय/निर्देशों का पूर्ण रूप से अनुपालन सुनिश्चित कराने का कष्ट करें।

संलग्न-यथोक्त।

भवदीय,

(बृजेश कुमार संत)har
Sant सचिव।
Date: 04-01-2024 13:05:06

संख्या- 04 /SOCW3/1/2024-XVII-A-3(66857), तददिनांक।

प्रतिलिपि निम्न को सूचनार्थ एवं आवश्यक कार्यवाही हेतु प्रेषित:-

1. सचिव, सामाजिक न्याय और अधिकारिता मंत्रालय, भारत सरकार, नई दिल्ली।
2. प्रबन्ध निदेशक, उत्तराखण्ड बहुउद्देशीय वित्त एवं विकास निगम, देहरादून।
3. प्रबन्ध निदेशक, पेयजल निगम, उत्तराखण्ड, देहरादून।
4. निदेशक, समाज कल्याण उत्तराखण्ड हल्द्वानी-नैनीताल।
5. निदेशक, शहरी विकास विभाग, उत्तराखण्ड।
6. निदेशक, पंचायती राज विभाग, उत्तराखण्ड।
7. समस्त जिलाधिकारी, उत्तराखण्ड।
8. मुख्य महाप्रबन्धक, उत्तराखण्ड जल संस्थान, देहरादून।
9. समस्त जिला समाज कल्याण अधिकारी, उत्तराखण्ड।
10. गार्ड फाईल।

True copy

(बृजेश कुमार संत)
सचिव।

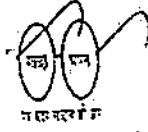

शहरी विकास निदेशालय, उत्तराखण्ड।
31/62, राजपुर रोड, देहरादून-24800

E-mail - info.uddukia@gmail.com, दूरभाष- 0135-2749541, फैक्स: 0135-2749542

संख्या-3761 /290/सूडा/शा0वि0नि0-रिट/2024,

दिनांक 05 जनवरी, 2024

सेवा में

अपर राक्षिप,
शहरी विकास विभाग,
उत्तराखण्ड, शासन।

विषय-

मा0 उच्चतम न्यायालय में योजित रिट याचिका संख्या-324/2020 डॉ0 बलराम सिंह बनाम भारत संघ व अन्य के सम्बन्ध में।

महोदय,

कृपया उपर्युक्त विषयक शहरी विकास अनुभाग-3, उत्तराखण्ड शासन के ई पत्रांक-1179847/2024, दिनांक 04 जनवरी, 2024 का सन्दर्भ ग्रहण करना चाहें, जिसके द्वारा मा0 उच्चतम न्यायालय के आदेश दिनांक 20-10-2023 के बिन्दुओं का अनुपालन सुनिश्चित करने के निर्देश दिये गये हैं।

2- उक्त के क्रम में निदेशालय के पत्रांक-3874, दिनांक 04-01-2024 (प्रति संलग्न) द्वारा समस्त नगर निकायों को अनुपालन सुनिश्चित किये जाने हेतु निर्देशित किया गया।

3- अतः मा0 उच्चतम न्यायालय के आदेश दिनांक 20-10-2023 के बिन्दुओं में विभाग से सम्बन्धित बिन्दुओं की अनुपालन आख्या निम्नवत् प्रेषित की जा रही है:-

96 (2)	All States and Union Territories are likewise, directed to ensure that all departments, agencies, corporations, and other agencies (by whatever name called) ensure that guidelines and directions framed by the Union are embodied in their own guidelines and directions; the states are specifically directed to ensure that such directions are applicable to all municipalities, and local bodies functioning within their territories;	All ULB's have been directed to ensure that, the guidelines and directions embodied in their own guidelines and directions. All the guidelines issued by Central and State Government will be strictly followed.
96 (3)	The Union, State and Union Territories are directed to ensure that full rehabilitation (including employment to the next of kin, education to the wards, and skill training) measures are taken in respect of sewage workers, and those who die;	All ULB's will ensure full rehabilitation of regular employees in respect of sewage workers and those who die.
96 (4)	The court hereby directs the Union and the States to ensure that the compensation for sewer deaths is increased. (given that the previous amount fixed, i.e., Rs. 10 lakhs) was made applicable from 1993. The current equivalent of that amount is Rs. 30 lakhs. This shall be the amount to be paid, by the concerned agency, i.e., the Union, the Union Territory, or the State as the case may be. In other words, compensation for sewer deaths shall be Rs. 30 lakhs. In the event, dependents of any victim have not been paid such amount, the above amount	The directions of state government in this regard will be complied with.

	shall be payable to them. Furthermore, this shall be the amount to be hereafter paid, as compensation.	
96 (5)	Likewise, in the case of sewer victims suffering disabilities, depending upon the severity of disabilities, compensation shall be disbursed. However, the minimum compensation shall not be less than Rs. 10 lakhs. If the disability is permanent, and renders the victim economically helpless, the compensation shall not be less than Rs. 20 lakhs.	The directions of state government in this regard will be complied with.
96 (6)	The appropriate government (i.e., the Union, State or Union Territories) shall devise a suitable mechanism to ensure accountability, especially wherever sewer deaths occur in the course of contractual or "outsourced" work. This accountability shall be in the form of cancellation of contract, forthwith, and Imposition of monetary liability, aimed at deterring the practice.	The direction has been issued to all ULB's in this regard vide letter no. 3874, dated 04.01.2024. It will be ensured that all directions are complied with.

संलग्नक-यथोपरि।

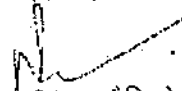
भुवदीय,

 (नितिन सिंह भदौरिया)
 निदेशक।

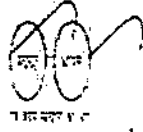
//True copy//



शहरी विकास निदेशालय, उत्तराखण्ड।

31/62, राजपुर रोड, देहरादून-24800

E mail - info.udduk@gmail.com, दूरभाष - 0135-2749541 फ़ैस. 0135-2749542

Email/Speed Post/By Hand

संख्या-3874/290/सूडा/शोविनि-रिट/2024,

दिनांक 04 जनवरी, 2024

सेवा में,

1-- समस्त नगर आयुक्त,
नगर निगम,
उत्तराखण्ड।

2-- अधिशारी अधिकारी,
नगर पालिका परिषद्/नगर पंचायत,
उत्तराखण्ड।

विषय- मा0 उच्चतम न्यायालय में योजित रिट याचिका संख्या-324/2020 डॉ0 बलराम सिंह बनाम भारत संघ व अन्य के सम्बन्ध में।

महोदय,

कृपया उपर्युक्त विषयक शहरी विकास अनुभाग-3, उत्तराखण्ड शासन के ई पत्रांक-1/179847/2024, दिनांक 04 जनवरी, 2024 (प्रति संलग्न) का सन्दर्भ ग्रहण करना चाहें, जिसके द्वारा मा0 उच्चतम न्यायालय के आदेश दिनांक 20-10-2023 के विन्दुओं का अनुपालन सुनिश्चित करने के निर्देश दिये गये हैं।

2- अतः निर्देशित किया जाता है कि शासन के पत्र दिनांक 04-01-2024 में उल्लिखित मा0 उच्चतम न्यायालय के आदेश दिनांक 20-10-2023 के प्रस्तर-96 के विन्दु-06 व 07 का प्राथमिकता के आधार पर अनुपालन सुनिश्चित करने का कष्ट करें।

3- उपरोक्त के अतिरिक्त उप सचिव, सामाजिक, न्याय और अधिकारिता मंत्रालय, भारत सरकार के पत्र दिनांक 14-11-2023 की प्रति एवं मा0 उच्च न्यायालय के आदेश दिनांक 20-10-2023 की छायाप्रति भी इस निर्देश सहित संलग्न कर प्रेषित की जा रही है कि कृपया मा0 उच्च न्यायालय के आदेश में उल्लिखित विन्दु संख्या-1 से 14 में पारित आदेशों का प्राथमिकता के आधार पर नियमानुसार अनुपालन सुनिश्चित करने का कष्ट करें।

संलग्नक-यथोपरि।

भवदीय,

(डॉ0 ललित नारायण मिश्र)

अपर निदेशक,

कृते निदेशक।

//True copy//

232

संलग्नक-यथोपरि

पत्र संख्या 2436/आधीन/बोसबि0/2023-24 दिनांक 6 जनवरी, 2024

सेवा में,

संयुक्त सचिव,

समान कक्ष, विभाग,

उतराखण्ड शासन।

विषय:- श्री0 उच्चतम न्यायालय में याचिका रिट याचिका संख्या-324/2020 जो10 बरगम सिंह बर्गम भारत सेवा व अन्य के सम्बन्ध में।

महोदय,

उपरोक्त विषयक संयुक्त सचिव, समान कक्ष, विभाग, उतराखण्ड शासन के पत्र संख्या 06 दिनांक 04.01.2024 का संदर्भ ग्रहण करने का कष्ट करे, जिसके द्वारा श्री0 उच्चतम न्यायालय में याचिका रिट याचिका संख्या 324/2020 में पारित आदेश दिनांक 20.10.2023 के विरुद्धों पर अनुपालन सुनिश्चित करने के निदेश दिए गए हैं।

2. उक्त के क्रम में निदेशालय के पत्र संख्या 2435, दिनांक 06.01.2023(आयाचिका संलग्न) द्वारा समस्त जिला प्रशासन राज आधिकारी एवं अपर मुख्य अधिकारी, जिला प्रशासन, उतराखण्ड को अनुपालन सुनिश्चित किए जाने हेतु निर्देश किया गया।

3. अतः श्री0 उच्चतम न्यायालय के आदेश दिनांक 20.10.2023 के प्रसर-96 के विरुद्धों पर विभाग से सम्बन्धित विरुद्धों की अनुपालन आख्या निम्नप्रति प्रेषित की जा रही है:-

<p>96 (2)</p> <p>All States and Union Territories are likewise, directed to ensure that all departments, agencies, corporations, and other agencies (by whatever name called) ensure that guidelines and directions framed by the Union are embodied in their own guidelines and directions; the states are specifically directed to ensure that such directions are applicable to all municipalities, and local bodies functioning within their territories;</p> <p>All DPRO's/AMA's have been directed to ensure that the guidelines and directions embodied in there own guidelines and directions issued by Central and State Government will be strictly followed.</p>	<p>96 (3)</p> <p>The Union, State and Union Territories are directed to ensure that full rehabilitation (including employment to the next of kin, education to the wards, and skill training) measures are taken in respect of sewage workers, and those who die;</p> <p>All DPRO's/AMA's will ensure full rehabilitation of regular employees in respect of sewage workers and those who die.</p>	<p>96 (4)</p> <p>The court hereby directs the Union and the States to ensure that the compensation for sewer deaths is increased (given that the previous amount fixed, i.e., Rs. 10 lakhs) was made applicable from 1993. The current equivalent of that amount is Rs. 30 lakhs. This shaft be the amount to be paid, by the concerned agency, i.e., the Union, the Union Territory, or the State as the case may be. In other words, compensation for</p>
-----------------------------------------------------------------------------------------------------------------------------------------------------------------------------------------------------------------------------------------------------------------------------------------------------------------------------------------------------------------------------------------------------------------------------------------------------------------------------------------------------------------------------------------------------------------------------------------------------------------------------------------------------------------------------	----------------------------------------------------------------------------------------------------------------------------------------------------------------------------------------------------------------------------------------------------------------------------------------------------------------------------------------------------------------------------------------------------	-------------------------------------------------------------------------------------------------------------------------------------------------------------------------------------------------------------------------------------------------------------------------------------------------------------------------------------------------------------------------------------------------------------------------------------------------------------

True copy
M. M. M.

निदेशालय पंचायतीराज, उत्तराखण्ड
डाण्डालखौण्ड, नियर आई.टी. पार्क, सहस्रधारा रोड, देहरादून

दूरभाष : 0135-2607855

director.pr.uk@gmail.com

	sewer deaths shall be Rs. 30 lakhs. In the event, dependents of any victim have not been paid such amount, the above amount shall be payable to them. Furthermore, this shall be the amount to be hereafter paid, as compensation.	
96 (5)	Likewise, in the case of sewer victims suffering disabilities depending upon the severity of disabilities, compensation shall be disbursed. However, the minimum compensation shall not be less than Rs. 10 lakhs. If the disability is permanent, and renders the victim economically helpless, the compensation shall not be less than Rs. 20 lakhs.	The directions of state government in this regard will be complied with.
96 (6)	The appropriate government (i.e., the Union, State or or Union Territories) shall devise a suitable mechanism to ensure accountability, especially wherever sewer deaths occur in the course of work. This "outsourced" contractual accountability shall be in the form of cancellation of contract, forthwith, and imposition of monetary liability, aimed at deterring the practice.	The direction has been issued to all DPRO's/AMA's in this regard vide letter no. 2435, dated 06.01.2024. It will be ensured that all directions are complied with.

संलग्न:-यथोपरि।

भवदीय,

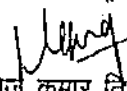
(मनोज कुमार तिवारी) 6/1/2024
उप निदेशक

प्रतिलिपि :- निम्नांकित को सूचनार्थ एवं आवश्यक कार्यवाही हेतु प्रेषित।

1. सचिव, पंचायती राज विभाग, उत्तराखण्ड शासन।

(मनोज कुमार तिवारी)
उप निदेशक

//True copy//

11/2024
23/1/24

235
True copy

	<p>The court hereby directs the Union and the States to ensure that the compensation for sewer deaths is increased (given that the previous amount fixed, i.e., Rs. 10 lakhs) was made applicable from 1993. The current equivalent of that amount is Rs. 30 lakhs. This shall be the amount to be paid by the concerned agency, i.e., the Union, the Union Territory, or the State as the case may be, in other words, compensation for sewer deaths shall be Rs. 30 lakhs. In the event, dependents of any victim have not been paid such amount, the above amount shall be payable to them. Furthermore, this shall be the amount to be paid to the</p>	96 (4)
	<p>The Union, State and Union Territories are directed to ensure that full rehabilitation (including employment to the next of kin, education to the wards, and skill training) measures are taken in respect of sewage workers, and those who die:</p>	96 (3)
	<p>All States and Union Territories are likewise, directed to ensure that all departments, agencies, corporations, and other agencies (by whatever name called) ensure that guidelines and directions framed by the Union are embodied in their own guidelines and directions; the states are specifically directed to ensure that such directions are applicable to all municipalities, and local bodies functioning within their territories;</p>	96 (2)

करना सुनिश्चित करें:-

अतः निर्दिष्ट किया जाता है कि शासन के पत्र दिनांक 04.01.2024 में उल्लिखित मा० उच्चतम न्यायालय के आदेश दिनांक 20.01.2023 के अन्तर्-96 के निम्न बिन्दुओं पर प्राथमिकता के आधार पर अनुपालन सुनिश्चित करने के निर्देश दिए गए हैं।

मा० उच्चतम न्यायालय के दिनांक 20.10.2023 के बिन्दुओं पर अनुपालन दिनांक 04.01.2024 का संदर्भ ग्रहण करने का कष्ट करें (उपरोक्त संलग्न), जिसके द्वारा मा० उच्चतम न्यायालय उपरोक्त विषयक संयुक्त सचिव, समाज कल्याण विभाग, उत्तराखण्ड शासन के पत्र संख्या 06

महोदय,

अन्य के सम्बन्ध में।

विषय:- मा० उच्चतम न्यायालय में योजित रिट याचिका संख्या-324/2020 उ० बलराम सिंह बरनाम भारत संघ व

उत्तराखण्ड।

1. भारत विना प्रवापत राज अधिकारी,
2. भारत अपर मुख्य अधिकारी,

सेवा में,

पत्र संख्या 2435/आयु/बी05810/2023-24 दिनांक 8 जनवरी, 2024

निदेशालय पंचायतीराज, उत्तराखण्ड
डाण्डालखौण्ड, नियर आई.टी. पार्क, सहस्रधारा रोड, देहरादून

दूरभाष : 0135-2607855

director.pr.uk@gmail.com

	paid, as compensation.	
96(5)	Likewise, in the case of sewer victims suffering disabilities, depending upon the severity of disabilities, compensation shall be disbursed. However, the minimum compensation shall not be less than Rs. 10 lakhs, if the disability is permanent, and renders the victim economically helpless, the compensation shall not be less than Rs. 20 lakhs.	
96(6)	The appropriate government (i.e., the Union, State or or Union Territories) shall devise a suitable mechanism to ensure accountability, especially wherever sewer deaths occur in the course of work. This "outsourced" contractual accountability shall be in the form of cancellation of contract, forthwith, and imposition of monetary liability, aimed at deterring the practice.	
96(12)	The Union, State and Union Territories are hereby directed to ensure co-ordination with all the commissions (NCSK, NCSC, NCST) for setting up of state level, district level committees and commissions, in a time bound manner. Furthermore, constant monitoring of the existence of vacancies and their filling up shall take place.	
96(14)	A portal and a dashboard, containing all relevant information, including the information relating to sewer deaths, and victims, and the status of compensation disbursement, as well as rehabilitation measures taken, and existing and available rehabilitation policies shall be developed and launched at an early date.	

संलग्न-यथोपरि।

भवदीय,

Moj
(मनोज कुमार तिवारी)
उप निदेशक

प्रतिलिपि :- निम्नांकित को सूचनार्थ एवं आवश्यक कार्यवाही हेतु प्रेषित।

1. सचिव, पंचायती राज विभाग, उत्तराखण्ड शासन।

Moj
6/1/2024
(मनोज कुमार तिवारी)
उप निदेशक

1/1/2024

236

1/1/2024

कार्यालय महाप्रबन्धक
निर्माण मण्डल (गंगा)
उत्तराखण्ड पेयजल निगम,
जागजीतपुर, पोस्ट-कनखल
हरिद्वार-249408



Office of General Manager
Construction Circle (Ganga)
Uttarakhand Pejal Nigam,
Jagjeetpur, Post-Kankhal,
Haridwar-249408

Email:-gmgangahw@gmail.com

Letter No. 42 / विविध-4 / 01 date 05-01-2024

सेवा में,

मुख्य अभियन्ता (मु०),
प्रधान कार्यालय,
उत्तराखण्ड पेयजल निगम,
देहरादून।
ई-मेल :- campcehq.upsvnn@gmail.com

विषय :- मा० सर्वोच्च न्यायालय में योजित रिट पिटीशन (सिविल), संख्या-324 / 2020 डॉ० बलराम सिंह बनाम भारत संघ व अन्य के सम्बन्ध में।

महोदय,

उपरोक्त विषयक प्रधान कार्यालय की ई-मेल दिनांक 29.12.2023 के माध्यम से प्राप्त अनु सचिव, पेयजल एवं स्वच्छता अनुभाग-1, उत्तराखण्ड शासन, देहरादून के पत्रांक 1144/31353/2023 दिनांक 26.12.2023 एवं उप सचिव, शहरी विकास अनुभाग-3, उत्तराखण्ड शासन, देहरादून के पत्रांक 176403/IV(3)-2023-8(01 बैठक)17 दिनांक 20.12.2023 के साथ संलग्न भारत सरकार के पत्रांक U-12021/1/2023-PLAN दिनांक 14.11.2023 में रिट याचिका संख्या 324 / 2020 डॉ० बलराम सिंह बनाम भारत संघ व अन्य में मा० उच्चतम न्यायालय, नई दिल्ली द्वारा पारित आदेश दिनांक 20.10.2023 के सम्बन्ध में आख्या निम्नानुसार प्रेषित है :-

बिन्दु संख्या	बिन्दु	आख्या
96 (2)	All States and Union Territories are likewise, directed to ensure that all departments, agencies, corporations and other agencies (by whatever name Called) ensure that guidelines and directions framed by the Union are embodied in their own guidelines and directions; the states are specifically directed to ensure that such directions are applicable to all municipalities, and local bodies functioning within their territories;	Uttarakhand Pejal Nigam will also ensure that guidelines and directions framed by the Union are embodied in their own guidelines and directions. All the guidelines issued by central and state government will be strictly followed.
96 (3)	The Union, State and Union Territories are directed to ensure that full rehabilitation (including employment to the next of kin, education to the wards, and skill training) measures are taken in respect of sewage workers, and those who die;	Uttarakhand Pejal Nigam will ensure full rehabilitation (including employment to the next of kin, education to the wards, and skill training) measures are taken in respect of sewage workers, and those who die.
96 (4)	The court hereby directs the Union and the States to ensure that the compensation for sewer deaths is increased (given that the previous amount fixed, i.e., Rs. 10 lakhs) was made applicable from 1993. The current equivalent of that amount is Rs. 30 lakhs. This shall be the amount to be paid, by the concerned agency, i.e., the Union, the Union Territory or the State as the case may be. In other words, compensation for sewer deaths shall be Rs. 30 lakhs. In the event, dependents of any victim have not been paid such amount, the above amount shall be payable to them. Furthermore, this shall be the amount to be hereafter paid, as compensation.	Will be ensured by Uttarakhand Pejal Nigam as per the directions of State Government.

237

True copy//

96 (5)	Likewise, in the case of sewer victims suffering disabilities, depending upon the severity of disabilities, compensation shall be disbursed. However, the minimum compensation shall not be less than Rs. 10 lakhs, if the disability is permanent, and renders the victim economically helpless, the compensation shall not be less than Rs. 20 lakhs.	Will be ensured by Uttarakhand Peyjal Nigam as per the directions of State Government.
96 (6)	The appropriate government (i.e., the Union, State or Union Territories) shall devise a suitable mechanism to ensure accountability, especially wherever sewer deaths occur in the course of contractual or "outsourced" work. This accountability shall be in the form of cancellation of contract, forthwith, and imposition of monetary liability, aimed at deterring the practice.	Will be ensured by Uttarakhand Peyjal Nigam as per the directions of State Government.
96 (10)	The Union, State and Union Territories are hereby required to set up scholarships to ensure that the dependents of sewer victims, (who have died, or might have suffered disabilities) are given meaningful education.	Will be ensured by Uttarakhand Peyjal Nigam as per the directions of State Government.
96 (12)	The Union, State and Union Territories are hereby directed to ensure co-ordination with all the commissions (NCSK, NCSC, NCST) for setting up of state level, district level committees and commissions, in a time bound manner. Furthermore, constant monitoring of the existence of vacancies and their filling up shall take place.	Action will taken by State Government to setup committees at different level.

भवदीय

(आर०के० जैन)
महाप्रबन्धक

पृष्ठांकन एवं दिनांक तदैव।

प्रतिलिपि निम्नलिखित को सूचनार्थ एवं आवश्यक कार्यवाही हेतु प्रेषित।

1. महाप्रबन्धक (प्रशासन), प्रधान कार्यालय, उत्तराखण्ड पेयजल निगम, देहरादून।
2. महाप्रबन्धक (बा०स०कार्य०/जे०जे०एम०), प्रधान कार्यालय, उत्तराखण्ड पेयजल निगम, देहरादून।

महाप्रबन्धक

//True copy//

238

प्रेषक,

निदेशक
समाज कल्याण
हल्द्वानी-नैनीताल।

सेवा में, च

सचिव
उत्तराखण्ड शासन
समाज कल्याण अनुभाग - 03
देहरादून।

पत्रांक - 2854 /स0क0/ अ0स0पे0छा0/ 2023-24

दिनांक : 05 - जनवरी, 2024

विषय - मा0 उच्चतम न्यायालय में योजित रिट याचिका (सिविल) संख्या - 324/2020 डॉ0 बलराम सिंह बनाम भारत संघ एवं अन्य में मा0 न्यायालय द्वारा पारित आदेश दिनांक 20-10-2023 के क्रियान्वयन के संबंध में।

महोदय,

कृपया उपर्युक्त विषयक शासन के पत्र संख्या 06/XVII-1-3/2024-13(03)/2023 T-C-दिनांक 04-जनवरी-2024 का संदर्भ ग्रहण करने का कष्ट करें जिसके द्वारा उपरोक्त प्रकरण से संबंधित आदेश के प्रस्तर 96 में उल्लिखित विन्दुओं पर सूचना चाही गई है।

अवगत कराना है कि राज्य में Manual Scavengers Act, 2013 का क्रियान्वयन वर्तमान में बहुउद्देशीय वित्त एवं विकास निगम द्वारा किया जा रहा है। निदेशालय स्तर से अनुसूचित जाति एवं अन्य हेतु पूर्वदेशम छात्रवृत्ति योजना का संचालन किया जा रहा है जिसमें एक घटक ऐसे छात्रों हेतु है जिनके माता-पिता अथवा अभिभावक अस्वच्छ पेशे में कार्यरत हैं किन्तु उक्त छात्रवृत्ति केवल कक्षा 9 एवं 10 के छात्रों हेतु है।

मा0 न्यायालय के आदेश के प्रस्तर 96 (10) में अस्वच्छ पेशे में कार्य के दौरान मृत हुए अथवा दिव्यांग हुए व्यक्तियों के आश्रितों को छात्रवृत्ति देने हेतु प्राविधान के संबंध में निर्देशित किया गया है। वर्तमान में ऐसे व्यक्तियों के आश्रितों हेतु पृथक से किसी भी छात्रवृत्ति योजना का संचालन निदेशालय द्वारा नहीं किया जा रहा है। अतः कृपया सूचना महोदय की सेवा में अवलोकनार्थ प्रस्तुत है।

भवदीय

(आशीष भटगाई)
निदेशक।

सचिव

//True copy//

239

मा0 उच्चतम न्यायालय में योजित रिट याचिका (सिविल) संख्या - 324/2020 डॉ0 बलराम सिंह बनाम भारत संघ एवं अन्य में मा0 न्यायालय द्वारा पारित आदेश दिनांक 20-10-2023 के क्रियान्वयन के संबंध में विवरण

• सामाजिक न्याय एवं अधिकारिता विभाग, सामाजिक न्याय एवं अधिकारिता मंत्रालय द्वारा अनुसूचित जाति के छात्रों एवं अन्य हेतु पूर्वदशम छात्रवृत्ति योजना संचालित है जिसके दिशानिर्देश वर्ष 2021-22 में जारी किए गए।

• उक्त छात्रवृत्ति के दो घटक हैं-

➤ घटक I- अनुसूचित जाति के पात्र छात्रों हेतु कक्षा 9 एवं 10 हेतु छात्रवृत्ति।

➤ घटक II- कक्षा 9 एवं 10 में अध्ययनरत ऐसे छात्रों को छात्रवृत्ति जिनके माता-पिता / अभिभावक अस्वच्छ पेशे में कार्यरत हैं। इस घटक हेतु जाति अथवा धर्म बंधन नहीं है।

• सचिव महोदय, समाज कल्याण विभाग के कार्यालय के पत्र संख्या 1082 दिनांक 11-दिसंबर-2023 के द्वारा महानिदेशक, शिक्षा विभाग एवं समस्त जिलाधिकारियों को पत्र लिखते हुए उपरोक्त छात्रवृत्ति के घटक II में उल्लिखित छात्रों के चिन्हीकरण हेतु निर्देशित किया गया है।

• अवगत कराना है कि भारत सरकार के दिशानिर्देशानुसार घटक II में ऐसे छात्रों को ही छात्रवृत्ति देय है जिनके माता-पिता / अभिभावक अस्वच्छ पेशे में कार्यरत हैं।

Component 2 : Pre-Matric scholarship for children of parents/ guardians engaged in Unclean and hazardous Occupation -

i. The students should be studying in classes I to X on full time basis

ii. Scholarship will be admissible to the children/ wards of parents/guardians who, irrespective of their caste/ religion belong to one of the following categories -

a. Persons who are Manual Scavengers as defined under section 2(I)(g) of Manual Scavengers Act 2013

b. Tanners & Flayers

c. Waste Pickers and

o Persons engaged in hazardous cleaning as defined in Section 2 (i) (d) of MS Act 2013

• वर्तमान में अस्वच्छ पेशे में कार्य करते हुए मृतक होने वाले अथवा दिव्यांग होने वाले व्यक्तियों के आश्रितों को पृथक से कोई छात्रवृत्ति योजना संचालित नहीं है।

Handwritten signature and stamp area with the text "this copy" written diagonally.

240

उत्तराखण्ड बहुउद्देशीय वित्त एवं विकास निगम लि०,
(उत्तराखण्ड सरकार का उपक्रम)

प्रधान कार्यालय- जनजाति कल्याण निदेशालय परिसर, भगतसिंह कॉलोनी, अधोईवाला,
देहरादून CIN U91990UR2001SGC026311

Website : www.ubvvn.org.in email : vikasnigam12@gmail.com

पत्रांक 1044 /बहु0नि0/एम0एस0एक्ट सूचना/2023-24
सेवा में,

दिनांक 04 जनवरी 2023

अपर सचिव,
समाज कल्याण, अनुभाग-03,
उत्तराखण्ड शासन।

विषय- मैनुवल स्कैवेन्जर्स के पुनर्वास हेतु स्वरोजगार योजना के संबन्ध में।
महोदय,

उपरोक्त विषयक से सन्दर्भित आपके कार्यालय पत्र संख्या- 475/XVII-A-3/2023-13(03)/2023 दिनांक 24 नवम्बर 2023 के क्रम में उत्तराखण्ड बहुउद्देशीय वित्त एवं विकास निगम द्वारा संचालित मैनुवल स्कैवेन्जर्स के पुनर्वास हेतु स्वरोजगार संबंधी योजनाओं का संक्षिप्त विवरण निम्नवत् है।

1. मैनुवल स्कैवेन्जर्स के पुनर्वास हेतु स्वरोजगार योजनान्तर्गत योजना प्रारम्भ से वर्ष 2023-24 तक कुल 5205 स्वच्छकार एवं उनके आश्रितों को राष्ट्रीय सफाई कर्मचारी वित्त एवं विकास निगम द्वारा कुल 2082.00 लाख की धनराशि एकमुश्त नकद सहायता (OTCA) के रूप में भुगतान की गयी है।
2. योजनान्तर्गत कुल 70 चिन्हित स्वच्छकारों को स्वयं का रोजगार स्थापित करने हेतु रु० 44.69 लाख अनुदान एवं रु० 87.67 लाख बैंक ऋण के रूप में उपलब्ध कराया गया।
3. सीवर/सैप्टिक टैंक की सफाई में मृत 09 व्यक्तियों के उत्तराधिकारियों को कुल 82.00 लाख की धनराशि का भुगतान किया गया है।
4. उक्त योजना के अन्तर्गत 176 स्वच्छकार/आश्रितों को उनके कौशल विकास हेतु विभिन्न व्यवसायों में प्रशिक्षण प्रदान किया गया है।

उक्त आख्या आपकी सेवा में प्रेषित है।

नोट- पूर्व में प्रेषित इस कार्यालय के पत्र संख्या- 256 दिनांक 22.07.2021 द्वारा बिन्दु संख्या- 02 की लाभार्थियों की संख्या- 287 स्वच्छकारों को संशोधित करते हुए पुनः 70 चिन्हित स्वच्छकार अंकित किये गये हैं।

भवदीय,

महाप्रबन्धक

241

Annex 482 - IV - M

Government of West Bengal
Backward Classes Welfare Department
Administrative Building, DJ-4, Sector-II, Salt Lake City, Kolkata-700091
www.anagrasarkalyan.gov.in

No. BCW-17099/22/2022/692239

Dated: 28.12.2023

From: J. G. Majumder
Assistant Secretary to the Govt. of West Bengal.

To: The Deputy Secretary,
Ministry of Social Justice and Empowerment,
Department of Social Justice and Empowerment, GOI

Sub: Furnishing Compliance Report on the observations as depicted in the Judgement of the Hon'ble Supreme Court of India in Writ Petition (Civil) No. 324 of 2020 filed by Dr. Balram Singh vs. Union of India & Ors.

Ref:- Letter No. U-12021/1/2023-PLAN dated 14.11.2023 of MOSJE, GOI

Sir,

in connection with the subject and reference cited above, I am directed to furnish herewith the Compliance Report on the observations as depicted in the Judgement of the Hon'ble Supreme Court of India In Writ Petition (Civil) No. 324 of 2020 filed by Dr. Balram Singh vs. Union of india & Ors. in a tabular format:-

SL No	Observation and directions of Hon'ble Court vide Order dated 20.10.2023	Action taken by the Govt. of West Bengal
3(1)	MS Act, 2013; MS Rules 2013 and guidelines framed by the Union are embodied in States/UTs guidelines and directions are applicable to all municipalities and local bodies.	Government of West Bengal is strictly abiding by the guidelines depicted in the MS Act, 2013 and MS Rules 2015.
3(2)	Full rehabilitation (including employment to the next of kin, education to the wards, and skill training) of sewage workers and those who die.	All the 96 persons identified in the first survey were provided One Time Cash Assistance, training and stipend, loan with subsidy assistance under SRMS to take up their chosen alternative occupations. All the 637 persons identified in the 2nd phase in 2019-20 were provided OTCA @Rs. 40,000/- to their Bank Account. Awareness camps are being organized to avoid health hazards and to educate the Safai Karmacharis about the use of safety devices. The ULBs availed soft loan from NSKFDC for procurement of sanitation vehicle, equipment under Swachatta Udyami Yojana (SUY).
3(3)	Payment of Compensation with increased amount i.e. Rs. 30 lakhs for sewer deaths. In the event, dependents of any victim have not been paid such amount, the above amount shall be payable to them, hereafter as compensation.	MOSJE vide Letter No. U-12021/1/2023-PLAN dated 14.11.2023 has communicated this Department regarding payment of compensation with increased amount i.e 30 lakhs for sewer deaths. MOSJE has informed that in the event, dependents of any victim have not been paid such amount, the above amount shall be payable to them, hereafter as compensation. This direction will be followed by the Govt. of West Bengal.
3(4)	Payment of compensation of Rs. 20 lakhs, in the case of sewer victims suffering disabilities, depending upon the severity of disabilities. Minimum	MOSJE vide Letter No. U-12021/1/2023-PLAN dated 14.11.2023 has communicated this Department regarding payment of compensation where it has been mentioned that payment of compensation of Rs. 20 lakhs, in the case of sewer victims suffering disabilities, depending upon the

	compensation shall not be less than Rs. 10 Lakhs.	severity of disabilities. Minimum compensation shall not be less than Rs. 10 lakhs. This direction will be followed by the Govt. of West Bengal.
3(5)	Devise suitable mechanism to ensure accountability, especially wherever sewer deaths occur in the course of contractual or "outsourced" work	The existing practice of Manual Cleaning of Swears and septic Tanks has been prohibited by the Act. ULBs & RLBS, as per requirement, are introducing Mechanization, providing safety suits, safety gears etc.. Safety gadgets like Mask, hand gloves, jackets, helmet, and safety lamps are being used. 267 nos. jetting machine and 303 nos. of cess-pools are presently in operation in the Municipal Bodies. State Govt. is contemplating to provide additional machines. Devise suitable mechanism is always followed for ensuring accountability, especially wherever sewer deaths occur in the course of contractual or "outsourced" work.
3(6)	Set up scholarships to ensure that the dependents of sewer victims (who have died, or might have suffered disabilities) are given meaningful education.	Backward Classes Welfare Department provides scholarship to all eligible applicants under the scheme "Pre-Matric Scholarship for SC students and others (Component-II)" for the children belonging to families of identified manual Scavengers or persons engaged in unclean occupation.
3(7)	Ensure establishment of State Commission for Safai Karmacharis and all committees mentioned in MS Act, 2013 and MS Rules 2013 Including State Monitoring Committee, State Level Survey Committee, District Vigilance Committee and District Level Survey Committee	West Bengal Scheduled Castes, Scheduled Tribes and Other Backward Classes Development & Finance Corporation has been designated as State Commission for Safai Karmacharis vide Notification No. 3526-BCW/6S(MC)-25/2022 dated 20.09.2022. State Monitoring Committee was constituted vide Notification No. 3248-BCW dated 31.12.2021; State and District Level Survey Committee have been notified vide No. 676-BCW/6M(MC)-03/13(Part-III) and District level Vigilance Committee has been notified vide No. 762-BCW/6M(MC)-3/13, dated 26.02.2014. (All copies of Notifications enclosed).

In this regard, this is further to inform you that with reference to D.O. No. U-12021/1/2023-PLAN dated 26.05.2023 of MOSJE, this Department has already furnished the desired report regarding implementation of various provisions of MS Act, 2013 as per prescribed proforma vide Letter No. BCW-17099/29/2022/607579 dated 13.06.2023 of this Department. However, a copy of the report is again enclosed for your ready reference.

This department also furnished the desired report on the status of manual scavenging free districts in respect of West Bengal vide this Department's Letter No. BCW-17099/22/2022/653876(Part-I) dated 07.09.2023 to MOSJE. However, a copy of the report is again enclosed for your ready reference.

Encl: As stated

Yours faithfully,

Fm
Assistant Secretary

True copy!!

243

The



Kolkata **Gazette**

सत्यमेव जयते

Extraordinary
Published by Authority

ASVINA 1]

FRIDAY, SEPTEMBER 23, 2022

[SAKA 1944

PART I—Orders and Notifications by the Governor of West Bengal, the High Court, Government Treasury, etc.

GOVERNMENT OF WEST BENGAL

Backward Classes Welfare Department

Administrative Building, DJ-4, Sector-11, Salt Lake City, Kolkata-700091

www.anagrasarkalyan.gov.in

No. 3526-BCW/6S(MC)-25/2022

Dated: 20.09.2022

NOTIFICATION

In exercise of the power conferred by sub-section (1) of section 32 of "The Prohibition of Employment as Manual Scavengers and their Rehabilitation Act, 2013" (hereinafter referred to as MS Act, 2013), the Governor is pleased to designate West Bengal Scheduled Castes, Scheduled Tribes and Other Backward Classes Development & Finance Corporation for Safai Karmacharis, to perform, within the State of West Bengal, *mutatis mutandis*, the following functions specified in sub-section (1) of section 31 of MS Act, 2013.

1. To monitor the implementation of the MS Act, 2013;
2. To enquire into complaints regarding contravention of the provisions of this Act, and to convey its findings to the concerned authorities with recommendations requiring further action, and--
3. To advise the Government of West Bengal for effective implementation of the provisions of this Act;
4. To take *suo motu* notice of matter relating to non-implementation of this Act

West Bengal Scheduled Castes, Scheduled Tribes and Other Backward Classes Development & Finance Corporation, since designated under sub-section (1) of section 32 of MS Act, 2013 shall, within the State of West Bengal, have, *mutatis mutandis*, the powers of the National Commission for Safai Karmacharis as specified in sub-section (2) of section 31 viz. West Bengal Scheduled Castes, Scheduled Tribes and Other Backward Classes Development & Finance Corporation, in the discharge of its functions under sub-section (1) of section 31, shall have the power to call for information with respect to any matter specified in that sub-section from any Government or local or other authority.

This will come into effect from the date of issuance of this notification.

By order of the Governor,

//True copy//

244

SANJAY BANSAL

Secretary to the Government of West Bengal

The

Kolkata Gazette
सत्यमेव जयते
Extraordinary
Published by Authority

MAGHA 26]

TUESDAY, FEBRUARY 15, 2022

[SAKA 1943

PART I—Orders and Notifications by the Governor of West Bengal, the High Court, Government Treasury, etc.

GOVERNMENT OF WEST BENGAL
Backward Classes Welfare Department
Administrative Building, DJ-4, Sector-II, Salt Lake City, Kolkata-700091
www.anagrasarkalyan.gov.in

NOTIFICATION

No. 3248-BCW/6M(MC)-3/13 (Pt-III), dated the 31st December, 2021.— In exercise of the power conferred by sub-section (1) of section 26 of the Prohibition of Employment As Manual Scavengers And Their Rehabilitation Act, 2013 (No. 25 of 2013) (hereinafter referred to as the said Act) and in supersession of the earlier notifications on the subject, the Governor is pleased hereby, to constitute, with immediate effect, the State Monitoring Committee, with the following members, namely:—

- (a) Janab Firhad Hakim, Minister-in-Charge, Transport and Housing Department, Government of West Bengal --
Chairperson, *ex-officio*;
- (b) Shri Bulu Chik Baraik, Minister-of-State (Independent Charge), Backward Classes Welfare & Tribal
Development Department;
- (c) Representatives of the National Commission for Scheduled Castes, and Safai Karmacharis - member,
ex-officio;
- (d) Nominees of the State Government from the State Legislature belonging to the Scheduled Caste—
- (i) Smt Asima Patra, M.L.A., Dhanekhali (SC) AC;
- (ii) Shri Swarna Kamal Saha, M.L.A., Entally AC;
- (e) The Director General of Police - member, *ex officio*;
- (f) (i) Additional Chief Secretary, Department of Home & Hill Affairs,
(ii) Additional Chief Secretary, Department of Panchayats and Rural Development, and
(iii) Principal Secretary, Urban Development & Municipal Affairs Department;

True copy//

245

- (g) (i) The Commissioner, Kolkata Municipal Corporation;
(ii) The General Manager, Eastern Railway; and
(iii) The General Manager, South Eastern Railway;
- (h) Four social workers from among the organization working for the prohibition of manual scavenging and rehabilitation of manual scavengers or representing the scavenger community resident in the State, namely—
(i) Shri Ram Pyare Ram, ex MLA;
(ii) Shri Rajpal Balmiki, representing the Safai Karmachari Andolan, recognized by the Ministry of Social Justice and Empowerment, Government of India;
(iii) Ms. Seema Figga, member of NGO "Maharishi Balmiki Seva Sangha";
(iv) Ms. Anjali Balmiki, representing the Safai Karmachari Andolan, recognized by the Ministry of Social Justice and Empowerment, Government of India;
- (i) The Convener, State Level Bankers' Committee & GM, Punjab National Bank or their representative—member, *ex officio*;
- (j) The Principal Secretary, Backward Classes Welfare Department-Member-Secretary, *ex-officio*;
- (k) The Director, State Urban Development Agency, Urban Development & Municipal Affairs Department;
- (l) The Managing Director, West Bengal Scheduled Castes, Scheduled Tribes and Other Backward Classes Development and Finance Corporation.

By order of the Governor,

DR. A. SUBBLAH

Principal Secretary to the Government of West Bengal

True copy//

246

The
Kolkata Gazette



सत्यमेव जयते

Extraordinary
Published by Authority

MAGHA 30]

THURSDAY, FEBRUARY 19, 2015

[SAKA 1936

PART I—Orders and Notifications by the Governor of West Bengal, the High Court, Government Treasury, etc.

GOVERNMENT OF WEST BENGAL
BACKWARD CLASSES WELFARE DEPARTMENT
ADMINISTRATIVE BUILDING, DJ-4, SECTOR-II, SALT LAKE, KOLKATA-700 091
Website : www.anagrasarkalyan.gov.in

NOTIFICATION

No. 676-BCW/6M (MC)-03/13 (Part. III) – the 19th February, 2015. — In exercise of the powers conferred by section 36 of the Prohibition of Employment as Manual Scavengers and their Rehabilitation Act, 2013 (25 of 2013), the Governor is pleased hereby to make the following rules, namely:—

CHAPTER I

GENERAL

1. **Short title and commencement.**— (1) These rules may be called the West Bengal Prohibition of Employment as Manual Scavengers and their Rehabilitation Rules, 2015.

(2) It shall come into force on the date of their publication in the *Official Gazette*.

2. **Definitions.**— (1) In these rules, unless the context otherwise requires,—

(a) “Act” means the Prohibition of Employment as Manual Scavengers and their Rehabilitation Act, 2013 (25 of 2013);

(b) “cleaning device” means and includes the equipments referred to in rule 5, manually or mechanically propelled and used to—

- (i) clean or enable the transport or flow of sewage in sewers septage from septic tanks; and
- (ii) avoid direct manual contact with sewage or material;

(c) “Chief Executive Officer” means—

- (i) the Municipal Commissioner, or the Commissioner, in case of the Municipal Corporation;

//True copy//

247

- (ii) the Executive Officer, in case of the Municipalities or notified area authorities or industrial township and in absence of these officers, the officials performing duties of these officers or any other officer of the Municipality concerned, as may be nominated by such officers for the purpose;
- (iii) in respect of *Panchayat* bodies,—
- (A) the *Pradhan*, in case of the *Gram Panchayat*; or
- (B) the Executive Officer in case of the *Panchayat Samiti* or *Zilla Parishad* or *Mahakuma Parishad*; or
- (C) in absence of these officers, the officials performing duties of these officers; or any other officer of the *Gram Panchayat* or *Panchayat Samiti* or *Zilla Parishad* or *Mahakuma Parishad* concerned as may be nominated by the State Government; and
- (iv) in respect of area under Gorkha Territorial Administration (GTA) in the district of Darjeeling, the Principal Secretary of Gorkha Territorial Administration and in absence of this officer, the official performing the duties of this officer or any other officer of Gorkha Territorial Administration to be nominated by the State Government;
- (d) "District Level Survey Committee" means the District Level Survey Committee consisting of—
- | | |
|---------------------------------------------------------------------------------------------------------------------------------------------------------------------------------|-------------------|
| (1) District Magistrate | Chairman; |
| (2) District Level Officer dealing with Scheduled Castes Affairs | Member-Secretary; |
| (3) District Statistical Officer | Member; |
| (4) one representative of <i>Zilla Parishad</i> | Member; |
| (5) representatives of two Municipalities/Gram Panchayats to be nominated by the District Magistrate | Member; |
| (6) District Level Officer of Municipal Affairs or Panchayat and Rural Development Department | Member; |
| (7) one representative of railway authority | Member; |
| (8) upto two representatives of Non Governmental Organizations working for Welfare of manual scavengers and <i>Safai Karmacharis</i> to be nominated by the District Magistrate | Member; |
| (9) upto two community representatives of whom one should be a woman to be nominated by the District magistrate | Member; |

for the purpose of discharging the following functions:—

- (i) to monitor and observe the survey process at District level,
- (ii) to distribute materials for awareness campaign to designated place,
- (iii) to arrange publicity through local newspapers etc. about the survey,
- (iv) to distribute translated survey material to designated place under its jurisdiction,
- (v) to approve final list of manual scavengers for all towns cities and villages in the district,
- (vi) to publish final consolidated list of the manual scavengers in the district;
- (e) "enumerator" means any person engaged by a local authority for the purpose of survey or verification of manual scavengers;
- (f) "inspector" means a person appointed as an inspector by the State Government by notification under sub section (1) of section 20 of the Act;
- (g) "overseer" means an officer engaged by a local authority to exercise the powers and perform the duties under these rules;

248
True copy

- (h) "protective gear" means personal safety gear and safety devices that are to be provided, worn or used by *safai karmacharis* or sanitary workers in respect of cleaning of sewers and septic tanks that may be necessary for the specific nature of work to be carried out including and not limited to the materials referred to under rule 4 to, -
- (i) avoid any exposure of human skin to substances which can lead to diseases along with all breathing equipment which prevents inhalation of gases which can lead to disease and also includes any sensory equipment for detection of gases present inside the sewers or septic tanks;
- (ii) avoid any injuries while carrying cleaning work;
- (i) "*Safai Karmachari*" or "Sanitation Worker" means any persons engaged in or employed for any sanitation work other than domestic work;
- (j) "safety precautions" means and includes the precautions referred to in rule 6 and necessary to reduce the risk to the person and to avoid contraction of diseases and injuries by the persons engaged in cleaning of sewers and septic tanks due to exposure to sewage or any other material in any physical state (solid, liquid or gas inside the sewers or septic tanks while entering sewers or septic tanks;
- (k) "State Level Survey Committee" means a State Level Committee consisting of
- | | |
|-------------------------------------------------------------------------------------------------------------------------------------------------------------------------------------------------------------------------------------------|-----------|
| (1) Additional Chief Secretary or Principal Secretary, nominated by the State Government | Chairman; |
| (2) Principal Secretary or Secretary dealing with Scheduled Castes, if the Committee is chaired by the Additional Chief Secretary, or Director, Scheduled Caste Welfare, if Principal Secretary, Scheduled Caste Welfare, is the Chairman | Member; |
| (3) Director, Economics and Statistics | Member; |
| (4) Secretary, Municipal Affairs Department/Panchayat & Rural Development Department | Member; |
| (5) Regional Director, Census Operations | Member; |
| (6) One representative of railway authority | Member; |
| (7) upto two representatives of Non Government Organizations working for Welfare of Manual Scavengers and <i>Safai Karmacharis</i> to be nominated by the State Government | Member; |
| (8) upto two community representatives of whom one should be a woman to be nominated by the State Government | Member; |

for the purpose of discharging the following functions, namely:-

- (i) to monitor and observe the survey process at state level;
- (ii) to distribute the materials for awareness campaign to designated place;
- (iii) to arrange publicity through local newspapers etc. about the survey;
- (iv) to distribute translated survey material to designated place under its jurisdiction;
- (v) to approve final list of manual scavengers for all towns cities and villages in the district;
- (vi) to publish final consolidated list of the manual scavengers in the district.

(2) Words and expressions used and not defined in these rules but defined in the Act, shall have the same meanings as assigned to them in the Act.

CHAPTER II

OBLIGATIONS OF EMPLOYER TOWARDS EMPLOYEES ENGAGED IN THE
CLEANING OF SEWER OR SEPTIC TANK

3. Obligations of employer towards employees engaged in cleaning of Sewer or Septic Tank.—(1) No person shall be allowed to clean a sewer manually, without the protective gear and safety devices under these rules except—

- (a) for the removal of concrete or reinforced plastic or damaged manhole door, where mechanical equipments cannot be put into operation;
- (b) for inter-linking the newly laid sewer main with the existing sewer main, in case of sewer of size of more than 300 mm diameter;
- (c) for removal of submersible pump sets fixed at the bottom of the suction wells;
- (d) for the reconstruction of the manhole or rectification of the sewer main;
- (e) for any other circumstances, when it is absolutely necessary to have manual sewage cleaning, after the Chief Executive Officer of the local authority has permitted to do so and after recording in writing the specific valid reasons for allowing such cleaning.

(2) For the purposes of clauses (c) and (d) of sub-rule (1), sewage shall be totally emptied before allowing entry of a person in the sewer.

4. Employer to provide for safety devices mandatorily.— Any person engaged to clean a sewer or a septic tank shall be provided by his employer, protective gear and safety devices like—

- (i) air compressor for blower;
- (ii) air line breathing apparatus;
- (iii) air line respirator with manually operated air blower;
- (iv) air purifier gas mask/chin corcege;
- (v) artificial respiration/reticulate;
- (vi) barrier caution tape;
- (vii) barrier cream;
- (viii) barrier cone;
- (ix) blower;
- (x) breath mask;
- (xi) breathing Apparatus;
- (xii) caution board;
- (xiii) chlorine mask;
- (xiv) emergency medical oxygen resuscitator kit;
- (xv) first aid box;
- (xvi) face mask;
- (xvii) gas monitor (4 gases);
- (xviii) guide pipe set;
- (xix) full body wader suit;
- (xx) fishing wader snit attached with boots;
- (xxi) hand gloves;
- (xxii) helmet;
- (xxiv) helmet demolishing;

1/True copy

- (xxv) lead acetate paper;
- (xxvi) life guard pad;
- (xxvii) modular airloes supply trolley system;
- (xxviii) normal face mask;
- (xxix) nylon rope ladder 5 meters;
- (xxx) nylon safety belt;
- (xxxi) pocket book;
- (xxxii) port oxy;
- (xxxiii) raincoat;
- (xxxiv) reflecting jacket;
- (xxxv) safety belt;
- (xxxvi) safety body clothing;
- (xxxvii) safety body harness;
- (xxxviii) safety goggles;
- (xxxix) safety gumboots;
- (xl) safety helmet;
- (xli) safety showers;
- (xlii) safety torch;
- (xliii) safety tripod set;
- (xliv) search light;

5. *Obligations of local authority towards employees engaged in cleaning of Sewer or Septic Tank.*—The local authority shall ensure that the following cleaning devices are used by persons engaged in cleaning sewer or septic tank which include but not limited to the following:—

- (i) sewer line cleaning bucketing machine;
- (ii) jetting machine;
- (iii) suction machine (gulley emptier) ;
- (iv) combined machine (jetting cum suction) ;
- (v) deep suction combined machine (jetting cum suction machine) ;
- (vi) manual hand operated grab bucket;
- (vii) hydraulic operated trolley mounted grab bucket;
- (viii) truck mounted motor & winch operated grab bucket machine;
- (ix) fixed Structure mounted motor & winch operated grab bucket machine;
- (x) rickshaw mounted winch & motor operated desilting machine for wet well;
- (xi) rickshaw mounted winch & auxiliary engine operated desilting machine for manhole;
- (xii) escort hydra crane mounted hydraulic winch operated grab bucket desilting machine;
- (xiii) manual rods, shovels, spades, drainage cleaning machines and steel scrapers with handles;
- (xiv) hoses and washing instruments;

6. *Employer's duty to check the cleaning devices before use.*— (1) All protective gear and safety devices under these rules shall be checked every six months and necessary repair or replacements shall be made by the employer who engages a person for cleaning a sewer or a septic tank.

(2) Comfortable bodysuits shall be made available to the worker who has to enter sewers or septic tanks for their cleaning. The employer shall provide full body suits to workers entering manholes of depth more than five feet and alternatively, partial fishing wader body suits to those entering manholes of depth less than five feet.

(3) The employer shall also ensure the following safety precautions before a person is engaged in the cleaning of a sewer or a septic tank, namely:-

- (a) a minimum of three employees shall remain present all the time of whom one shall be a supervisor;
- (b) the atmosphere within the confined space shall be tested for oxygen deficiency and toxic and combustible gases like hydrogen sulphide, carbon monoxide, methane, and gasoline vapours, through detection tests by way of :-
 - (i) lowering a detector lamp into the manhole;
 - (ii) inserting wet lead acetate paper which changes colour in the presence of hazardous gases;
 - (iii) detection of gases through gas detector masks.
- (c) before starting the cleaning under sub-rule (1) the supervisor referred to in clause (a) of sub-rule (3) shall inspect and determine if the sewer serves any industries nearby to anticipate any hazardous atmosphere that may be encountered;
- (d) the condition of metal-run ladders and the side walls of the manhole shall be checked to see if there is any danger of collapse;
- (e) traffic and pedestrian barricades are provided all the times;
- (f) a flagman should be stationed at least 50 feet ahead of a site and should be visible to incoming traffic for at least 500 feet;
- (g) regular medical check-up of sewage workers including the examination of respiratory organs, skin injuries, other occupational diseases and injuries to ensure that sewage workers afflicted with such disease or injuries do not enter sewers for cleaning;
- (h) regular vaccination against respiratory and skin diseases and other occupational diseases to which these workers are prone due to exposure to harmful substances and gases in sewers;
- (i) all employees who are present on site during cleaning work are given adequate training to familiarize with all equipments involved in cleaning work, to avoid injuries or diseases associated with such work and to take necessary steps in case of emergency arising at the place of work and the training shall be conducted every two years and the employees shall be familiarized with any changes in the method and technique with respect to the above. Standard norms set by the manufacturers or any competent authority are to be followed for training and familiarization of the employees with the operating of all such equipments;
- (j) the supervisor possesses and keeps handy the names, addresses and telephone numbers of the nearest hospitals or clinics;
- (k) Cleaning of a sewer or a septic tank shall be done:-
 - (i) only in day-light; and
 - (ii) for a duration not exceeding 90 minutes, at a stretch. There shall be a mandatory interval of 30 minutes between two stretches.
- (l) identify and close-off or re-route any lines that might carry harmful substances to or through the work area;
- (m) ensure that written operating and rescue procedures are displayed at the entry site;
- (n) if the entry is made through a top opening, use a housing device with a harness that suspends a person in an upright position and a mechanical device shall be available to retrieve personnel from vertical spaces more than five feet deep.

- (o) at least one person trained in first-aid and cardio-pulmonary re-suscitation should be made immediately available during any confined space job.
- (p) oxygen content in the manhole must be at least 19.5% in the confined space of the manhole measures at all levels (bottom, middle and top) and no person enters the manhole if oxygen level is below 19.5% and more than 21%;
- (q) ventilate the sewer line by opening at least two or three manholes on both sides where work is to be carried out;
- (r) manhole shall be opened at least one hour before the start of operation;
- (s) the opened manhole shall be properly fenced or barricaded to prevent any person, specially children, from accidentally falling into the sewer. Dummy cover with welded fabric or wire-net may be used;
- (t) all workers use the safety gear and safety devices before entering the sewer line;
- (u) the person entering the manhole or sewer line must be monitored using signal or camera or CCTV etc., through the operation period;
- (v) structural safety of manhole rungs or steps must be tested before entering the manhole;
- (w) portable aluminum ladder is available during the work period where necessary and the portable ladder is properly seated or fixed during use;
- (x) no material or tools are located near the edge which can fall into the manhole and injure the workman;
- (y) equipments used during sewer cleaning are explosion and fire-proof;
- (z) smoking open flames are prohibited inside the manhole as well as in the immediate vicinity of open manholes;
- (za) in the event of a sudden or unpredictable atmospheric change, an emergency escape breathing apparatus with at least a 10 minute air supply is worn.

7. **Precautionary measures for a person engaged in cleaning a septic tank etc.**— (1) The employer shall ensure the following safety precautions at the time when the person is engaged in the cleaning of a sewer or a septic tank—

- (a) portable fans and air blowers with batteries, in good working condition with a back up capacity of more than the estimated duration of the entry of the person in the sewer shall be carried into sewers for ventilation and a ventilation source shall be installed at the mouth of the man hole;
- (b) flashlights and communication devices such as two-way radios shall be carried into sewers;
- (c) presence of the following rescue equipment at the site—
 - (i) a tripod and harness system, or some other method ensuring maneuvering of an injured worker to the surface;
 - (ii) a basket stretcher, or similar device, shall be available for moving the injured worker to emergency transportation;
 - (iii) trained personnel shall be immediately available and first-aid facilities with instruments as given in Annexure I, shall be provided in the following manner:—
 - (A) at every work place, there shall be provided and maintained, so as to be easily accessible during working hours, not less than one first-aid box for 150 employees;
 - (B) the first-aid box shall be distinctly marked with a red cross on white background and shall contain such equipments as contained in PART A and PART B of Annexure I;
 - (C) Adequate arrangements shall be made for immediate recoument of the equipments when necessary;
 - (D) The first-aid box shall be kept in charge of a responsible person who shall always be readily available during the working hours of any work place.

- (E) A person-in-charge of the First-aid box shall be a person trained in first-aid treatment in the work places, where the number of employees employed is 150 or more.
- (F) In any work place where the number of employees employed is 500 or more and hospital facilities are not available within easy distance from the work place, first-aid post shall be established and run by a trained compounders and he shall be on duty and shall be available at all hours when the workers are at work.
- (G) Where any work places is situated in a place which is not town or city, a suitable motor transport shall be kept readily available to carry injured person or person suddenly taken ill to the nearest hospital.

(2) The employer shall ensure availability of ambulance and follow-up in close proximity.

(3) The employer shall ensure that the assigned person has life-insurance policy of at least ten lakh rupees and the premium for which shall be paid by the employer.

8. **Post cleaning safety precautions.**—The employer shall ensure the following post-cleaning safety precautions after a person engaged in the cleaning of a sewer or a septic tank comes out of the sewer or specific tank after a session of cleaning:-

- (a) to provide facilities for removal of contaminated clothing and for wash-up as well as cleaning dry clothing;
- (b) wash-up material including water soaps, hand sanitizers and medically authenticated skin cream for applying on the body for post cleaning safety;
- (c) any cut/bruises on the skin or problems with a respiratory organ suffered on account of cleaning of sewer shall be immediately cured.

CHAPTER III

INSANITARY LATRINES

9. **De-composition of human excreta.**—Human excreta shall be treated as fully decomposed when it eventually becomes stable material with no unpleasant smell and containing valuable plant nutrients.

10. **Survey of insanitary latrines.**— (1) Every local authority shall draw a suitable time schedule for carrying out survey of insanitary latrines within its jurisdiction and the publication of their list.

(2) The local authority shall take the assistance of the community leaders and non-governmental organizations working in the area for the welfare of the *Safai Karamcharis* or sanitary workers, on the existence of insanitary latrines in the area under its jurisdiction.

(3) Any complaint filed by any person including a non-governmental organization, regarding the construction, maintenance or use of insanitary latrine, shall be inquired by the local authority within fifteen days of filing the complaint.

(4) The local authority shall constitute a committee under its Chief Executive Officer with at least two members from the community of *Safai Karamcharis* or sanitary worker, one of whom shall be a woman and at least one member from the civil society group.

(5) The Committee referred to in sub-rule (4) shall plan and monitor the survey and ensure that an awareness campaign is carried out simultaneously with the survey that is conducted.

(6) The Chief Executive Officer of the local authority shall prepare an initial list of insanitary latrines existing in his jurisdiction and display the same at the notice-board of the office of the local authority and publish in two local daily newspapers, inviting the objections, specifying the date by which the objections, if any to the list, shall be received.

(7) The local authority shall cause to hold a meeting on the due date as specified to hear the complaints and objections received on the initial list and approve the final list of insanitary latrines.

(8) The final list of insanitary latrines shall be prepared and published by the local authority which shall display the same at the notice board of office of the local authority and publish in two local newspapers one of which shall be in the vernacular language.

(9) Within fifteen days of the final publication of list of insanitary latrines, the local authority shall serve a notice on the occupier of the insanitary latrine to either demolish such insanitary latrine or convert it into a sanitary latrine within a period of six months from the date of commencement of the Act.

(10) A copy of such notice referred to in sub-rule (9) shall be sent to the inspector.

(11) The notice referred to in sub-rule (9) shall include information regarding the schemes of the Central and State Government which entitle the beneficiaries to incentives for the demolition of insanitary latrines or conversion to sanitary latrines and/or other information regarding the eligibility to avail the benefits under those Schemes and the procedure for availing such benefits.

(12) The Committee referred to in sub-rule (4) shall submit the survey report to the District Magistrate, who, or any department designated by him for this purpose, in turn, shall submit the consolidated reports of all local authorities under his jurisdiction to State Level Survey Committee.

(13) The State Level Survey Committee shall furnish the report of the survey to the Central Ministry/Department dealing with the Schemes of conversion of insanitary latrines into sanitary latrines for the urban and rural areas.

(14) The eligible beneficiaries under the relevant Schemes of the Central or State Government may apply for the admissible financial assistance under such schemes.

(15) After the expiry of the period under sub-rule (9), the local authority shall have the premises of the occupier of insanitary latrine inspected.

(16) If the occupier has neither demolished nor converted the insanitary latrine into a sanitary latrine, the local authority shall order for its demolition and recover the cost from the occupier.

CHAPTER IV

SURVEY OF MANUAL SCAVENGERS

11. **Identification of the manual scavengers.**— (1) The local authority shall ensure that the persons conducting the survey of manual scavengers shall be adequately and appropriately trained by the local authority on the method and manner in which the survey shall be conducted and sensitized on the issue of manual scavenging.

(2) The State Level Survey Committee and the District Level Survey Committee shall carry out adequate campaigns at various levels especially in all such areas where insanitary latrines have been found during the survey.

(3) The local authority shall also associate community leaders or non-governmental organizations working for the welfare of *Safai Karamcharis* or sanitary workers in identification of manual scavengers.

(4) The local authority shall invite manual scavengers through awareness campaigns to declare themselves at the self declaration centre and have their details verified during a period and at places, which shall be notified by the local authority.

(5) The lists of manual scavengers, if provided by the non-governmental organizations or any other persons or agency, shall be fully verified to identify manual scavengers.

(6) In case, there is discrepancy between the data of insanitary latrines or the number of manual scavengers submitted by any person or organization, the local authority shall order a house-to-house survey of insanitary latrines by the enumerators to know the names of manual scavengers servicing those insanitary latrines.

(7) Local authority shall also make efforts to identify manual scavengers by visiting the habitations of concentration of *Safai Karamcharis*, sanitary workers or manual scavengers.

Government of West Bengal
Backward Classes Welfare Department
Writers' Buildings, Kolkata - 700 001
Website: www.anagrasarkalyan.gov.in

NOTIFICATION

No. 762-BCW/6M(MC)-3/13 the 26th February, 2014.-- In exercise of the power conferred by section 24 of the Prohibition of Employment as Manual Scavengers and their Rehabilitation Act, 2013 (25 of 2013) (hereinafter referred to as the said Act), the Governor is pleased hereby to constitute the following Vigilance Committee for each district and each sub-division to carry out the functions as mentioned in the said Act, namely:

(1) the Vigilance Committee for a district shall consist of the following members :

- (a) the District Magistrate -- Chairperson, *ex-officio*;
- (b) all members of the State Legislature belonging to the Scheduled Castes elected from the district - members :
Provided that if a district has no member of the State Legislature belonging to Scheduled Castes, the State Government may nominate such member of other members of the State Legislature from the district, not exceeding two, as it may deem appropriate.
- (c) the district Superintendent of Police - member, *ex-officio*;
- (d) the Chief Executive Officer of,
 - (i) the Panchayat at the district level - member, *ex-officio* ;
 - (ii) the Municipality of the district headquarters - member, *ex-officio* ;
 - (iii) any other Municipal Corporation constituted in the district--member, *ex-officio*;
 - (iv) Cantonment Board, if any, situated in the district - member, *ex-officio*;
- (e) one representative be nominated by the railway authority located in the district;
- (f) not more than four social workers belonging to organisation working for the prohibition of manual scavenging and rehabilitation of manual scavengers, or, representing the scavenger community, resident in the district, to be nominated by the District Magistrate, two of whom shall be woman;
- (g) one person to represent the financial and credit institutions in the district, to be nominated by the District Magistrate.
- (h) the district-level officer in-charge of the Scheduled Castes Welfare -- Member Secretary, *ex-officio*;
- (i) district-level officers of Departments and agencies who, in the opinion of the District Magistrate, subject to general orders, if any, of the State Government, have a significant role to play in the Implementation of this Act;

(2) each Vigilance Committee, constituted for a Sub-division, shall consist of the following members, namely:

- (a) the Sub-Divisional Magistrate - Chairperson, *ex-officio*;

- (b) the Chairpersons and the Chief Executive Officers of Panchayats at intermediate level of the Sub-Division, and where Panchayats at intermediate level, do not exist, Chairpersons from two Panchayats at Village level to be nominated by the Sub-Divisional Magistrate - member, *ex-officio*;
- (c) the Sub-Divisional Officer of Police - member, *ex-officio*;
- (d) the Chief Executive Officer of,-
(i) the Municipality of the Sub-Divisional headquarters - member, *ex-officio*; and
(ii) Cantonment Board, if any, situated in the Sub-Division - member, *ex-officio*;
- (e) one representative to be nominated by the railway authority located in the Sub-Division - member, *ex-officio*;
- (f) two social workers belonging to the organisation working for the prohibition of manual scavenging and rehabilitation of the manual scavengers, or representing the scavenger community resident in the Sub-Division, to be nominated by the District Magistrate; one of whom shall be woman;
- (g) one person to represent the financial and credit institutions in the Sub-Division, to be nominated by the Sub-Divisional Magistrate.
- (h) the Sub-Divisional Level officer in-charge of Scheduled Castes Welfare - Member-Secretary, *ex-officio*;
- (i) Sub-Divisional level officers of Department and agencies who, in the opinion of the Sub-Divisional Magistrate, subject to any general orders of the State Government or the District Magistrate, have a significant role to play in the implementation of this Act. - member, *ex-officio*.

(3) This notification shall come into force with immediate effect.

By order of the Governor,
Shadab
28/12/2014
Pr. Secy. to the Govt. of West Bengal.

//True copy//

257

Government of West Bengal
Backward Classes Welfare Department
Administrative Building, DJ-4, Sector-II, Salt Lake City, Kolkata-700091
www.anagrasarkalyen.gov.in

No. BCW-17099/29/2022/607579

Dated: 13.06.2023

From: Sanjay Bansal, IAS
Secretary to the Govt. of West Bengal.

To: Shri Saurabh Garg, IAS
Secretary, Ministry of Social Justice & Empowerment,
Department of Social Justice & Empowerment, Govt. of India

Sub: Report on the status of action taken in connection with the directions passed by the Hon'ble Supreme Court of India in Writ Petition (Civil) No. 324/2020 filed by Dr. Bairam Singh Vs Union of India & Ors.

Ref: This Department's earlier Communication vide No. BCW-17099/29/2022/572742 dated 27.03.2023

Sir,

In connection with the subject and reference cited above and with reference to your D.O. No. U-12021/01/2023-PLAN dated 26.05.2023, I am to enclose herewith the desired report as per prescribed proforma along with the requisite enclosures on the status of action taken towards enforcement of the provisions of the MS Act, 2013 for your kind perusal and taking necessary action.

Encl: As stated

Yours faithfully,

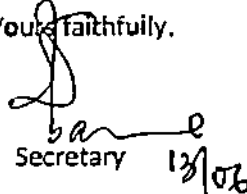
Secretary 13/06

No. BCW-17099/29/2022/607579 /1(1)

Dated: 13.06.2023

Copy forwarded for information with the enclosures as stated above to:

The Managing Director, West Bengal SC, ST & OBC Development and Finance Corporation.

Special Secretary to the Govt. of West Bengal

//True copy//

258

**Information as sought under DO No. U-12021/1/2023-Plan, Dated- 26/05/2023 of
Secretary, MOSJE**

Name of State: West Bengal

Sl No.	Name of the institution	Date of constitution or designating	Name of Commission/agency designated to act as Commission	If not, reasons thereof
1.	Constitution of State Safai Karmacharis Commission/ Designating agency (u/s 32 of MS Act, 2013)	20/09/2022	West Bengal SC, ST & OBC Development & Finance Corporation	Not applicable

Sl No.	Name of the Institution	Date of constitution	Date of last meeting	If not constituted, reasons thereof
2.	State Monitoring Committee (u/s 26 of MS Act, 2013)	31/12/2021 (last re-constituted)	08/09/2022	Not applicable
3.	District Vigilance Committee (u/s 24 of MS Act, 2013)	26/02/2014	4 meeting were held, last meeting 27.02.2023 District report collection is in progress.	Not applicable
4.	Sub-Division Vigilance Committee (u/s 24 of MS Act, 2013)	26/02/2014	9 meetings held, last meeting 23.08.2022 Sub Division report collection is in progress.	Not applicable
5.	State Level Survey Committee (Rule 2-j of MS Rules, 2013)	Notification No. 676-BCW/6M(MC)-03/13(Part - iii) dated 19-02-2015	In 2015	Not applicable
6.	District Level Survey Committee (Rule 2-c of MS Rules, 2013)	Notification No. 676-BCW/6M(MC)-03/13(Part - III) dated 19-02-2015	Howrah District Level Survey Committee meeting was held on 07.09.2021 and for other districts report collection is in progress.	Not applicable

7. Survey for identification of insanitary latrines & manual scavengers was conducted by State Urban Development Agency (SUDA) in 129 ULBs in the first phase in 2013-14 after enforcement of the MS Act 2013. Panchayat & Rural Development (P & RD) Department was entrusted with survey in the rural areas. Both the departments of the State Govt have verified that Rural and Urban Local bodies have declared their area as Open Defecation Free.
8. Since 2013, altogether 25 sewerage death cases have been reported. Out of these, compensation was paid in respect of 22 cases. Enquiry is in progress in respect of 3 cases of Nadia district which was reported in May, 2023. List of sewerage death cases are enclosed (Annexure-AA).

259

//True copy//

9. In the first round of survey conducted immediately after enforcement of the Act, 96 manual scavengers were identified in the 129 ULBs. However, no manual scavengers were identified in the rural areas. Following benefits were extended to each of the identified manual scavengers.-
- i) ID Cards in prescribed format
 - ii) One Time Cash Assistance (OTCA) @ Rs. 40,000
 - iii) Skill Training for 3 months & stipend @ Rs. 3,000 per month
 - iv) Concessional Loan with capital Subsidy under SRMS for rehabilitation in their chosen alternative occupation
 - v) Scholarships to children under Central Sector Scheme for families engaged in unclean occupations

In the second phase of survey in 2018-19 conducted in 6 districts of the State namely Darjeeling, Purba Bardhaman, Paschim Bardhaman, Howrah, North 24 Parganas & Kolkata 637 manual scavengers were identified. All of them were issued ID cards in prescribed format. Out of 637 identified persons, 533 expressed their willingness to be rehabilitated in alternative occupation through training, concessional loan & capital subsidy under the revised SRMS scheme. Accordingly, 533 loan applications were sponsored to the different bank branches. A general apathy to sanction loan applications was witnessed. The matter was discussed in the meeting of State Monitoring Committee held in September, 2022. The matter was further escalated to SLBC forum. Regional office of National Commission for SC also took up the matter with SLBC. In spite of vigorous persuasions, only 74 cases have so far been sanctioned & disbursed. NSKFDC was kept in the loop. Considering the situation, WBSCSTOBCDFC has taken a decision to rehabilitate the identified persons through NSKFDC loan & capital subsidy. In parallel, a campaign is in progress to collect information regarding skill training need & choice of alternative occupation by the identified MSs. This campaign has been taken up under instruction from NSKFDC. The entire matter is scheduled to be raised in the 9th meeting of the State Monitoring Committee.

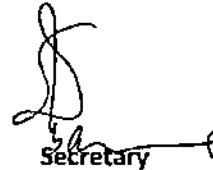

Secretary

Backward Classes Welfare Department

TRUE COPY



260

No. BCW-17099/22/2022/653876 (Part i)

Dated: 07.09.2023

From: Secretary to the Govt. of West Bengal.

To: Shri Saurabh Garg, IAS
Secretary, Ministry of Social Justice & Empowerment,
Department of Social Justice & Empowerment, Govt. of India

Sub: Furnishing report on the status of Manual Scavenging

Ref: Your D.O. Letter No. U-19014/14/2021-PLAN dated 07/07/2023

Sir,

in connection with the subject and reference cited above, I am to inform you that 15(Fifteen) districts namely Paschim Bardhaman, Jhargram, Darjeeling, Jalpaiguri, Maida, Hooghly, Murshidabad, Kailimpong, Paschim Medinipur, Aipurdwar, Birbhum, Coochbehar, Uttar Dinajpur, Dakshin Dinajpur and Kolkata in West Bengal who did not declare themselves as "Manual Scavenging Free" in West Bengal have declared themselves as "Manual Scavenging Free". Updation in the database of your district wise list on the status of manual scavenging for the above-mentioned districts may kindly be incorporated accordingly.

Yours faithfully,

Secretary 07/09



No. BCW-17099/22/2022/653876/1(6)(Part I)

Dated: 07.09.2023

Copy forwarded for information as stated above to:-

- 1) Shri. R. K. Khandelwal, IAS, Secretary, NCSK, Gol.
- 2) Smt. Yogita Swaroop, IES, Sr. Economic Adviser, MoSJE, Govt. of India.
- 3) The Principal Secretary, UDMA Department, GoWB
- 4) The Secretary, P&RD Department, GoWB
- 5) The Managing Director, WB SCSTOBC FC, GoWB
- 6) The Director, SUDA, UDMA Department, GoWB.

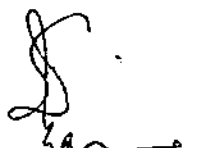
Secretary 07/09

TRUE COPY

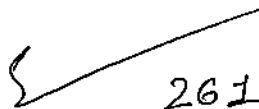
261

OUT AT ONCE
SUPREME COURT MATTER

SPEED POST

From No.SWD(RA)/MS Act/2023/ 10328

To The Director Social Welfare,
Women & Child Development
Chandigarh Administration

To

Sh.S.K.Srivastwa,
Deputy Secretary to the Government of India,
Department of Social Justice & Empowerment,
B-2 Ground Floor, Pt. Deendayal Antyodaya Bhawan,
CGO Complex, Lodhi Road,
New Delhi-110003.

Dated Chandigarh, the 29/12/23

**Subject:- Regarding Hon'ble Supreme Court Matter of WP(C)
No.324/2020 filed by Dr.Balram Singh Vs. Union of India
& Ors.**

Sir,

I am directed to refer to your DO-letter-No.U-12021/1/2023-PLAN dated 14.11.2023 and email dated 15.12.2023 regarding compliance report in respect of UT, Chandigarh on the directions of Hon'ble Supreme Court order dated 20.10.2023 passed in WP(C) No.324/2020 filed by Dr.Balram Singh Vs. Union of India & Ors. is enclosed as **ANNEXURE** for information, as desired.

Yours faithfully,



Research Officer,
for Director Social Welfare,
Women & Child Development,
Chandigarh Administration

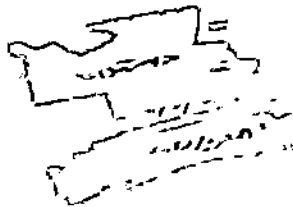

ANNEXURE

Sr. No.	Hon'ble Supreme Court directions/ observatoins given vide order dated 20.10.2023	Status/action taken report
1	MS Act, 2013; MS Rules 2013 and guidelines framed by the Union are embodied in States / UTS guidelines and directions are applicable to all municipalities and local bodies [para 96 (2)]	<p>Chandigarh being without legislature, follows the directions /instructions/guidelines issued by the Government of India/Central Govt. from time to time and are straightway implemented here in toto. These instructions are also applicable to Municipal Corporation, Chandigarh and local body of UT, Chandigarh.</p> <p>The status of implementation of Prohibition of Employment as Manual Scavengers and their Rehabilitation Act, 2013 (MS Act, 2013) is given as under:-</p> <ul style="list-style-type: none"> • All necessary notifications under the provisions of the Prohibition of Employment as Manual Scavengers and their Rehabilitation Act, 2013 (MS Act, 2013) vide notifications dated 06.04.2018 [Appendix-I] and 28.12.2023 [Appendix-II], as detailed below:- • Under Section 5(1) of the Act, The District Magistrate, UT, Chandigarh has been declared as an "Executive Authority" to exercise jurisdiction to ensure the compliance of the provisions of the Act, ibid. • Under Section 7 prohibition of persons from engagement or employment for hazardous cleaning of sewers and septic tanks. • Under Section 18, the powers has been conferred to the District Magistrate, UT, Chandigarh to ensure the provisions of the said Act are properly carried out in UT, Chandigarh. • Under Section 20, all Chief Sanitary Inspectors of Municipal Corporation has been appointed as Inspectors to ensure duties enforced under the said Act. • Under Section 21(1) & (2), the powers of Judicial Magistrate of first Class has been conferred to all the SDMs and they will act as Executive Magistrates for trial of offences under the Act. • Under Section 24, constituted a District Vigilance Committee to execute the functions defined under Section-25 of the "Prohibition of Employment as Manual Scavengers and their Rehabilitation Act, 2013" Act in Union Territory of Chandigarh. • Under Section 26, constituted a State Monitoring Committee to execute the functions defined under Section-27 of the "Prohibition of Employment as Manual Scavengers and their Rehabilitation Act, 2013" Act in Union Territory of Chandigarh. • Under Rule 11, constituted a District Level Survey Committee, to monitor and oversee the survey of manual scavengers and insanitary latrines and to execute the functions defined under the "Prohibition of Employment as Manual

//True copy//

		<p>Scavengers and their Rehabilitation Rules, 2013" in Union Territory of Chandigarh.</p> <ul style="list-style-type: none"> • Municipal Corporation Chandigarh has also implemented "The Prohibition of employment as Manual Scavengers and their rehabilitation Act 2013" in its jurisdiction as ordered by the Administrator, UT Chandigarh that no person, local authority or any agency shall engage/employ, either directly or indirectly, any person for hazardous cleaning of a sewer or a septic tank in the U.T. Chandigarh vide Notification No. RA/SWD-MS/2018/1885 dated 06.04.2018. Chandigarh Administration appointed the Deputy Commissioner, Chandigarh as the Responsible Sanitation Authority (RSA) for the UT, Chandigarh and the overall in-charge of ESRU vide Notification No.49925-FII(o)-2002/10045 dated 08.07.2022. • Further as per guidelines of govt. of India, M.C. Chandigarh deputed officers/staff to work in ESRU (Emergency Sanitation Response UNIT) SRU(Sanitation Response Unit) under RSA (Responsible Sanitation Authority) vide CMC office order No.89 dated 13.07.2022. • Further, Information Education and Communication (IEC) activities are being done to promote sanitation. Regular campaigns, awareness programmes in collaboration with RWAs, MWAs and Area Councillors are being held to motivate Safai Mitras.
2	Full rehabilitation (including employment to the next of kin, education to the wards and skill training) of sewage workers, and those who die [para 96.(3)]	As per report received from the Nodal Officer, MC, Chandigarh vide letter dated 14.12.2023 (Appendix-III), that employment has been given to the next of kin of deceased members. Further, regarding education and skill training to wards, the same has been noted for compliance.
3	Payment of compensation with increased amount i.e., 30 lakhs for sewer deaths, in the event, dependents of any victim have not been paid such amount, the above amount shall be payable to them, hereafter as compensation [para 96(4)]	As reported earlier by the Municipal Corporation, Chandigarh and O/o Chief Engineer, Chandigarh Administration, the status of compensation paid @ Rs.10.00 Lakh to the family of deceased persons had already been sent to the Ministry vide letter dated 30.06.2023 (Appendix-IV).
4	Payment of compensation of Rs.20 lakhs, in the case of sewer victims suffering in disabilities, depending upon the severity of disabilities. Minimum compensation sha not be less than 10 lakhs [para 96 (5)]	Nil information, as no such case reported till date where sewer victims suffering in disabilities. Also submitted that in UT, Chandigarh, manual cleaning of sewer has been completely stopped and maintenance of sewerage network is being done by using latest mechanical equipments/machinery.
5	Devise suitable mechanism to ensure accountability, especially wherever sewer deaths occur in the course of contractual or "outsourced" work [para 98 (8)]	Noted for compliance. Necessary instructions have been circulated to Municipal Corporation, Chandigarh vide letter dated 06.12.2013.
6	Set up scholarships to ensure	Noted for compliance and instructions have been

	that the dependents of sewer victims, (who have died, or might have suffered disabilities) are given meaningful education [para 96 (10)]	circulated to Municipal Corporation, Chandigarh vide letter dated 06.12.2013.
7	Ensure establishment of State Commission for Safai Karmacharis and all Committees mentioned in MS Act, 2013 and MS Rules 2013 including State Monitoring Committee. State Level Survey Committee, District Vigilance Committee and District Level Survey Committee by 30.11.2023 [para 96(12)]	<p>State Monitoring Committee u/s 26 and District Vigilance Committee u/s 24 of Manual Scavenger Act, 2013 and District Level Survey Committee under Rule, 11 of the Manual Scavenger Rule, 2013 have been constituted for executing the functions defined under the Manual Scavenger Act/Rules, 2013. Copy of the same is placed below at Appendix-II.</p> <p>Regarding constitution of Commission for Safai Karmacharis, the matter was taken up with the National Commission of Safai Karmacharis, New Delhi to exempt UT, Chandigarh for constitution of the State Commission in the absence of manual scavengers and insanitary latrines in UT, Chandigarh. In response, the National Commission for Safaikarmacharis suggested to designate any other agency to look after the work of State Commission as per provision of the MS Act. Therefore, accordingly, the functions of State Commission will be assigned soon to the State Monitoring Committee or District Vigilance Committee as per advice of the National Commission for SKs, New Delhi.</p>

//True copy//

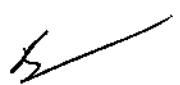

CHANDIGARH ADMINISTRATION
SOCIAL WELFARE DEPARTMENT

NOTIFICATION

No.RA/SWD-MS/2018/1879

Dated: 6/4/18

In supersession of earlier notification No.RA/SWD/2008/2072 dated 10.03.2008 and in exercise of the powers conferred by Sub-section (1) of Section 5 of the "Prohibition of Employment as Manual Scavengers and their Rehabilitation Act, 2013", the Administrator, UT, Chandigarh do hereby orders that no person shall engage in or employ for or permit to be engaged in or employed for any other person for manually carrying human excreta or construct or maintain a dry latrine in the Union Territory of Chandigarh. The Administrator, UT, Chandigarh further declares that the District Magistrate, Chandigarh shall act as 'Executive Authority' to exercise jurisdiction to ensure the compliance of the provisions of the Act, 1947, in the areas falling under U.T., Chandigarh as per provisions of the Act from the date of publication of this notification in the Official Gazette.

No.RA/SWD-MS/2018/1880

Secretary Social Welfare,
Chandigarh Administration
Dated: 6/4/18

A copy is forwarded to the District Magistrate, U.T., Chandigarh for information and necessary action.

[Signature]
Superintendent,
for Secretary Social Welfare,
Chandigarh Administration.

Dated: 6/4/18

RECORDED

No.RA/SWD-MS/2018/1881-82

A copy is forwarded to the :-
1. The Commissioner, Municipal Corporation, U.T., Chandigarh
2. The Director, Rural Development & Panchayat Office, UT, Chandigarh

for information and strict compliance.

[Signature]
Superintendent,
for Secretary Social Welfare,
Chandigarh Administration.

Dated: 6/4/18

No.RA/SWD-MS/2018/1883

A copy is forwarded to the Controller, Printing & Stationery Department, U.T., Chandigarh for information with request to publish the said notification in the next issue of Chandigarh Administration Gazette and supply 50 copies to this office for record.

[Signature]
Superintendent,
for Secretary Social Welfare,
Chandigarh Administration.

True copy

CHANDIGARH ADMINISTRATION
SOCIAL WELFARE DEPARTMENT

NOTIFICATION

No. RA/SWD-MS/2018/1885

Dated: 6/4/18

In exercise of the powers conferred under Section 7 of the "Prohibition of Employment as Manual scavengers and their Rehabilitation Act, 2013" (Central Act No.25 of 2013), the Administrator, UT, Chandigarh do hereby orders that no person, local authority or any agency shall engage/employ, either directly or indirectly, any person for hazardous cleaning of a sewer or a septic tank in the Union Territory of Chandigarh as per provisions of the Act from the date of publication of this notification in the Official Gazette.

Secretary Social Welfare,
Chandigarh Administration

No. RA/SWD-MS/2018/1886

Dated: 6/4/18

A copy is forwarded to the District Magistrate, U.T., Chandigarh for information and necessary action.

Superintendent,
for Secretary Social Welfare,
Chandigarh Administration

No. RA/SWD-MS/2018/1887-88

Dated: 6/4/18

A copy is forwarded to the :-

1. The Commissioner, Municipal Corporation, U.T., Chandigarh
2. The Director, Rural Development & Panchayat Office, UT, Chandigarh

for information and strict compliance.

Superintendent,
for Secretary Social Welfare,
Chandigarh Administration

No. RA/SWD-MS/2018/1889

Dated: 6/4/18

A copy is forwarded to the Controller, Printing & Stationery Department, U.T. Chandigarh for information with request to publish the said notification in the next issue of Chandigarh Administration Gazette and supply 50 copies to this office for record.

Superintendent,
for Secretary Social Welfare,
Chandigarh Administration

Scanned by CamScanner

//True copy//

CHANDIGARH ADMINISTRATION
SOCIAL WELFARE DEPARTMENT

NOTIFICATION

No.RA/SWD-MS/2018/1893

Dated: 6/4/18

In exercise of the powers conferred by Section 20 of the "Prohibition of Employment as Manual Scavengers and their Rehabilitation Act, 2013", the Administrator, UT, Chandigarh do hereby orders to appoint all the Chief Sanitary Inspectors working in Municipal Corporation, Union Territory, Chandigarh as Inspectors for the purpose of performing the duties enforced upon them under Section 20 of the said Act in their respective jurisdiction in UT, Chandigarh.

Secretary Social Welfare,
Chandigarh Administration

No.RA/SWD-MS/2018/1894

Dated: 6/4/18

A copy is forwarded to the District Magistrate, U.T., Chandigarh for information and necessary action.

Superintendent,
for Secretary Social Welfare,
Chandigarh Administration.

Dated: 6/4/18

No.RA/SWD-MS/2018/1895-96

A copy is forwarded to the :-

1. The Commissioner, Municipal Corporation, U.T., Chandigarh
2. The Director, Rural Development & Panchayat Office, UT, Chandigarh

for information and strict compliance.

Superintendent,
for Secretary Social Welfare,
Chandigarh Administration.

Dated: 6/4/18

No.RA/SWD-MS/2018/1897

A copy is forwarded to the Controller, Printing & Stationery Department, U.T., Chandigarh for information with request to publish the said notification in the next issue of Chandigarh Administration Gazette and supply 50 copies to this office for record.

Superintendent,
for Secretary Social Welfare,
Chandigarh Administration.

//True copy//

Scanned by CamScanner

Appendix IV

MS/Notification

CHANDIGARH ADMINISTRATION
SOCIAL WELFARE DEPARTMENT

NOTIFICATION

No.RA/SWD-MS/2018/1890

Dated: 6/4/18

In exercise of the powers conferred by Section 18 and duties under Section 19 of the "Prohibition of Employment as Manual Scavengers and their Rehabilitation Act, 2013", the Administrator, UT, Chandigarh do hereby orders that the District Magistrate, UT, Chandigarh should ensure the provisions of the said Act are properly carried out in UT, Chandigarh.

Secretary Social Welfare,
Chandigarh Administration

No.RA/SWD-MS/2018/1891

Dated: 6/4/18

A copy is forwarded to the District Magistrate, U.T., Chandigarh for information and necessary action.

Superintendent,
for Secretary Social Welfare,
Chandigarh Administration.

No.RA/SWD-MS/2018/1892

Dated: 6/4/18

A copy is forwarded to the Controller, Printing & Stationery Department, U.T., Chandigarh for information with request to publish the said notification in the next issue of Chandigarh Administration Gazette and supply 50 copies to this office for record.

Superintendent,
for Secretary Social Welfare,
Chandigarh Administration.

Scanned by CamScanner

True copy

270

CHANDIGARH ADMINISTRATION
SOCIAL WELFARE DEPARTMENT

NOTIFICATION

No.RA/SWD-MS/2018/1898

Dated: 6/4/18

In exercise of the powers conferred by Section 21(1) & Section 21(2) of the "Prohibition of Employment as Manual Scavengers and their Rehabilitation Act, 2013", and all other powers enabling him in this behalf, the Administrator, UT, Chandigarh is pleased to confer the powers of Judicial Magistrate of first Class upon the following Executive Magistrates within their respective jurisdiction in Union Territory of Chandigarh for trial of offences under the Act:-

1. Sub Divisional Magistrate (Central)
2. Sub Divisional Magistrate (East)
3. Sub Divisional Magistrate (South)

Secretary Social Welfare,
Chandigarh Administration

No.RA/SWD-MS/2018/1899

Dated: 6/4/18

A copy is forwarded to the District Magistrate, U.T., Chandigarh for information.

[Signature]
Superintendent,
for Secretary Social Welfare,
Chandigarh Administration.

No.RA/SWD-MS/2018/1900-02

Dated: 6/4/18

A copy is forwarded to all the concerned SDMs, UT, Chandigarh for information and necessary action.

[Signature]
Superintendent,
for Secretary Social Welfare,
Chandigarh Administration.

No.RA/SWD-MS/2018/1903-04

Dated: 6/4/18

A copy is forwarded to the:-

1. The Commissioner, Municipal Corporation, U.T., Chandigarh
2. The Director, Rural Development & Panchayat Office, UT, Chandigarh for information and strict compliance.

[Signature]
Superintendent,
for Secretary Social Welfare,
Chandigarh Administration.

No.RA/SWD-MS/2018/1905

Dated: 6/4/18

A copy is forwarded to the Controller, Printing & Stationery Department, U.T., Chandigarh for information with request to publish the said notification in the next issue of Chandigarh Administration Gazette and supply 50 copies to this office for record.

[Signature]
Superintendent,
for Secretary Social Welfare,
Chandigarh Administration.

True copy

**DEPARTMENT OF SOCIAL WELFARE, WOMEN & CHILD DEVELOPMENT
CHANDIGARH ADMINISTRATION**

NOTIFICATION

No.RA/MS Act/2023/ 10312

Dated: 28/12/23

In pursuance of Rule 11(2), 11(18) & 11(19) of the "Prohibition of Employment as Manual Scavengers and their Rehabilitation Rules, 2013", the Administrator, UT, Chandigarh is pleased to constitute a **District Level Survey Committee**, comprising the following, to monitor and oversee the survey of manual scavengers and insanitary latrines and to execute the functions defined under the "Prohibition of Employment as Manual Scavengers and their Rehabilitation Rules, 2013" in Union Territory of Chandigarh:-

- | | | |
|----|----------------------------------------------------------------------------------------------------------|---------------------|
| 1. | Deputy Commissioner
UT, Chandigarh | Chairperson |
| 2. | Joint Director Social Welfare
Chandigarh Administration | Member Secretary |
| 3. | Joint Commissioner,
Municipal Corporation, Chandigarh | Member |
| 4. | Research Officer,
Economics & Statistical Department,
UT, Chandigarh | Member |
| 5. | Sh.Shubham Pawar, ADEN/CDG (by designation)
Northern Railway, Ambala Cantt. | Member |
| 6. | Mr.Subhash Thakur, Head Sewermen (Retd.)
S/o Sh.Bhagwan Singh,
H.No.2348, Sector 38-C, Chandigarh. | Non-Official Member |
| 7. | Mr.Surinder Singh, Head Sewermen (Retd.)
S/o Sh.Ved Parkash, H.No.864, DMC,
Chandigarh. | Non-Official Member |
| 8. | Mr.Kamal, Head Sewermen (Retd.)
S/o Sh.Butta, H.No.1201, Ramdarbar, Ph-II,
Chandigarh. | Non-Official Member |

Dated:26.12.2023

NITIN KUMAR YADAV
Secretary Social Welfare,
Women & Child Development,
Chandigarh Administration

No.RA/MS Act/2023/ 10313

Dated: 28/12/23

A copy is forwarded to PA/DC-cum-District Magistrate, U.T., Chandigarh for information of the DC-cum-Distt. Magistrate, UT; Chandigarh please.

[Signature]

Director Social Welfare,
for Secretary Social Welfare,
Chandigarh Administration.

No.RA/MS Act/2023/ 10314

Dated: 28/12/23

A copy is forwarded to the all concerned Members and Non-Official Members for information and necessary action please.

[Signature]

Director Social Welfare,
for Secretary Social Welfare,
Chandigarh Administration.

No.RA/MS Act/2023/ 10315

Dated: 28/12/23

A copy is forwarded to the Controller, Printing & Stationery, Chandigarh Administration for information with request to publish the said notification in the next Gazette Chandigarh Administration.

[Signature]

Director Social Welfare,
for Secretary Social Welfare,
Chandigarh Administration.

//True copy//

**DEPARTMENT OF SOCIAL WELFARE, WOMEN & CHILD DEVELOPMENT
CHANDIGARH ADMINISTRATION**

NOTIFICATION

No.RA/MS Act/2023/ 10300

Dated: 28/12/23

In pursuance of Section 24 of the "Prohibition of Employment as Manual Scavengers and their Rehabilitation Act, 2013", the Administrator, UT, Chandigarh is pleased to constitute a **District Vigilance Committee**, comprising the following, to execute the functions defined under Section-25 of the "Prohibition of Employment as Manual Scavengers and their Rehabilitation Act, 2013" Act in Union Territory of Chandigarh:-

- | | | |
|-----|---------------------------------------------------------------------------------------------------------------|---------------------|
| 1. | District Magistrate
UT, Chandigarh | Chairperson |
| 2. | Medical Officer of Health,
Municipal Corporation, Chandigarh | Member |
| 3. | Sr. Superintendent of Police,
UT, Chandigarh | Member |
| 4. | Sub-Divisional Magistrate (Central)
UT, Chandigarh | Member |
| 5. | Sub-Divisional Magistrate (South)
UT, Chandigarh | Member |
| 6. | Sub-Divisional Magistrate (East)
UT, Chandigarh | Member |
| 7. | Chief Engineer
Municipal Corporation, Chandigarh | Member |
| 8. | Chief Sanitary Inspector
Municipal Corporation, Chandigarh | Member |
| 9. | Sh.Shubham Pawar, ADEN/CDG (by designation)
Northern Railway, Ambala Cantt. | Member |
| 10. | Lead Bank Manager
PNB, Chandigarh | Member |
| 11. | Director Social Welfare
Chandigarh Administration | Member Secretary |
| 12. | Company Secretary
Chandigarh Scheduled Castes Backward Classes
& Min. Fin. Dev. Corpn. Ltd., Chandigarh | Member |
| 13. | Mr.Subhash Thakur, Head Sewermen (Retd.)
S/o Sh.Bhagwan Singh,
H.No.2348, Sector 38-C, Chandigarh. | Non-Official Member |
| 14. | Mr.Surinder Singh, Head Sewermen (Retd.)
S/o Sh.Ved Parkash, H.No.864, DMC,
Chandigarh. | Non-Official Member |
| 15. | Mr.Kamal, Head Sewermen (Retd.)
S/o Sh.Butta, H.No.1201, Ramdarbar, Ph-II,
Chandigarh. | Non-Official Member |

Dated:26.12.2023

NITIN KUMAR YADAV
Secretary Social Welfare,
Women & Child Development,
Chandigarh Administration

No.RA/MS Act/2023/ 10309

Dated: 28/12/23

A copy is forwarded to PA/DC-cum-District Magistrate, U.T., Chandigarh for information of the DC-cum-Distt. Magistrate, UT, Chandigarh please.

[Signature]
Director Social Welfare,
for Secretary Social Welfare,
Chandigarh Administration.

No.RA/MS Act/2023/ 10310

Dated: 28/12/23

A copy is forwarded to the all concerned Members and Non-Official Members for information and necessary action please.

[Signature]
Director Social Welfare,
for Secretary Social Welfare,
Chandigarh Administration.

No.RA/MS Act/2023/ 10311

Dated: 28/12/23

A copy is forwarded to the Controller, Printing & Stationery, Chandigarh Administration for information with request to publish the said notification in the next Gazette Chandigarh Administration.

[Signature]
Director Social Welfare,
for Secretary Social Welfare,
Chandigarh Administration.

273
True copy

**DEPARTMENT OF SOCIAL WELFARE, WOMEN & CHILD DEVELOPMENT
CHANDIGARH ADMINISTRATION**

NOTIFICATION

No.RA/MS Act/2023/ 10316

Dated: 20/12/23

In pursuance of Section 26 of the "Prohibition of Employment as Manual Scavengers and their Rehabilitation Act, 2013", the Administrator, UT, Chandigarh is pleased to constitute a **State Monitoring Committee**, comprising the following, to execute the functions defined under Section-27 of the "Prohibition of Employment as Manual Scavengers and their Rehabilitation Act, 2013" Act in Union Territory of Chandigarh:-

1.	Adviser to the Administrator UT, Chandigarh.	Chairperson
2.	Home Secretary Chandigarh Administration	Member
3.	Secretary Social Welfare, Chandigarh Administration	Member
4.	Commissioner, Municipal Corporation -cum-Secretary Rural Development, Chandigarh.	Member
5.	Deputy Commissioner UT, Chandigarh	Member
6.	Director General of Police, UT, Chandigarh	Member
7.	Representative of National Commission for SC/ST Chandigarh.	Member
8.	Sh.Aditya Sharma, CDO (Gaz)/CDG (by designation) -cum-Dy.Director/Heritage Northern Railway, Ambala Cantt	Member
9.	Lead Bank Manager PNB, Chandigarh	Member
10.	Director Social Welfare Chandigarh Administration	Member Secretary
11.	Mr.Subhash Thakur, Head Sewermen (Retd.) S/o Sh.Bhagwan Singh, H.No.2348, Sector 38-C, Chandigarh.	Non-Official Member
12.	Mr.Surinder Singh, Head Sewermen (Retd.) S/o Sh.Ved Parkash, H.No.864, DMC, Chandigarh.	Non-Official Member
13.	Mr.Kamal, Head Sewermen (Retd.) S/o Sh.Butta, H.No.1201, Ramdarbar, Ph-II, Chandigarh.	Non-Official Member

Dated:26.12.2023

NITIN KUMAR YADAV
Secretary Social Welfare,
Women & Child Development,
Chandigarh Administration

No.RA/MS Act/2023/ 10317

Dated: 20/12/23

A copy is forwarded to PS/AA for information of the Worthy Adviser to the Administrator, UT, Chandigarh please.

[Signature]

Director Social Welfare,
for Secretary Social Welfare,
Chandigarh Administration.

Dated: 20/12/23

No.RA/MS Act/2023/ 10318

A copy is forwarded to the all concerned Members and Non-Official Members for information and necessary action please.

[Signature]

Director Social Welfare,
for Secretary Social Welfare,
Chandigarh Administration.

Dated: 20/12/23

No.RA/MS Act/2023/ 10319

A copy is forwarded to the Controller, Printing & Stationery, Chandigarh Administration for information with request to publish the said notification in the next Gazette Chandigarh Administration.

[Signature]

Director Social Welfare,
for Secretary Social Welfare,
Chandigarh Administration.

Dated: 20/12/23

True copy

274

01/15
11/22/23
11/22/23
11/22/23

F/B 23
Appendix-III

From

The Executive Engineer,
M.C.P.H. Division No. 4,
Chandigarh.

To

The Director Social Welfare,
Chandigarh Administration.

Memo No.....9429

Dated.....11/12/2023

Subject:

Writ Petition (Civil) No. 324 of 2020 filed by Dr. Balram Singh Vs. Union of India & Ors. Before Supreme Court of India- reg (Meeting notice and VC link for 15.12.2023 at 3:00 PM chaired by the Economic Advisor regarding Hon'ble Supreme Court Judgment dated 20.10.2023 inWP(C) No.324 of 2020.

Reference: Your office e-mail dated 14.12.2023.

DSW(Busy)

In this context, it is submitted that the reply in respects of points related to this office has been prepared as per detail below:-

ROI
1/2
RA

Sr. No.	Points	Reply
1.	MS Act, 2013; MS Rules 2013 and guidelines framed by the union are embodied in States/UTs guidelines and directions are applicable to all municipalities and local bodies [(para 96(2))]	<ul style="list-style-type: none"> • Municipal Corporation Chandigarh has implemented "The Prohibition of employment as Manual Scavengers and their rehabilitation Act 2013" in its jurisdiction as ordered by the Administrator, UT Chandigarh that no person, local authority or any agency shall engage/employ, either directly or indirectly, any person for hazardous cleaning of a sewer or a septic tank in the U.T. Chandigarh vide Notification No. RA/SWD-MS/2018/1885 dated 06.04.2018 • Chandigarh Administration appointed the Deputy Commissioner, Chandigarh as the Responsible Sanitation Authority (RSA) for the UT, Chandigarh and the overall in-charge of ESRU vide Notification No.49925-F11(o)-2002/10045 dated 03.07.2022. • Further as per guidelines of govt. of India, M.C. Chandigarh deputed officers/staff to work in ESRU (Emergency Sanitation Response Unit) SRU(Sanitation Response Unit) under RSA (Responsible Sanitation Authority) vide CMC office order No.89 dated 13.07.2022 • Further, it is intimated that as per Notification No. RA/SWD-MS/2018/1879 dated 06.04.2018 the Administrator, UT, Chandigarh has ordered that:- <ul style="list-style-type: none"> i) There is no engagement of person for manually carrying human excreta or construct or maintain a dry latrine in the UT Chandigarh. ii) The District Magistrate Chandigarh shall act as Executive Authority to ensure the compliance

//True copy//

275

		<p>of the Act ibid in the areas falling under the UT, Chandigarh for the Act.</p> <ul style="list-style-type: none"> • Further, Information Education and Communication (IEC) activities are being done to promote sanitation. Regular campaigns, awareness programmes in collaboration with RWAs, MWAs and Area Councillors are being held to motivate Safai Mitras • It is intimated that as per Notification No. RA/SWD-MS/2018/1879 dated 06.04.2018 the Administrator, UT, Chandigarh declared the District Magistrate Chandigarh shall act as Executive Authority to ensure the compliance of the Act ibid in the areas falling under the UT, Chandigarh for the Act. • It is intimated that as per Notification No. RA/SWD-MS/2018/1893 dated 06.04.2018, the Administrator UT Chandigarh appointed all the Chief Sanitary Inspector working in MC Chandigarh as inspector for the purpose of performing the duties enforced upon them under the Act. • it is intimated that as per Notification No. RA/SWD-MS/2018/1898 dated 06.04.2018 the Administrator UT Chandigarh conferred power of Judicial Magistrate of first class upon the Executive Magistrates within their respective jurisdiction for trial of offence under the Act.
2.	Full rehabilitation (including employment to the next of kin, education to the wards, and skill training) of sewage workers, and those who die [(para 96(3))]	It is submitted that employment has been given to the next of kin of deceased members.
3.	Payment of compensation with increased amount i.e. Rs. 30 lakhs for sewer deaths. In the event, dependents of any victim have not been paid such amount, the above amount shall be payable to them, hereafter as compensation [para 96(4)]	The payment of compensation with increased amount i.e. Rs.30 Lakhs in the event of sewer death in future. The necessary approval is required from the Competent Authority to give compensation amount i.e. Rs. 30 Lakh in future.
4.	Payment of compensation of Rs.20 lakhs, in the case of sewer victims suffering disabilities, depending upon the severity of disabilities. Minimum compensation shall not be less than Rs.10 lakhs [para 96(5)]	The payment of compensation of Rs.20 lakhs, in the case of sewer victims suffering disabilities, depending upon the severity of disabilities in future. The necessary approval is required from the Competent Authority to give compensation amount i.e. Rs. 20 Lakh in future.

276

True copy

5.	Devise suitable mechanism to ensure accountability, especially wherever sewer deaths occur in the course of contractual or "outsourced" work [para 96(6)]	Noted for compliance
6.	Set up scholarships to ensure that the dependents of sewer victims, (who have died, or might have suffered disabilities) are given meaningful education [para 96(10)]	Being a policy matter relates to Higher Authorities.
7.	Ensure establishment of State Commission for Safai Karamcharies and all committees mentioned in MS Act, 2013 and MS Rules 2013 including State Monitoring Committee, State Level Survey Committee, District Vigilance Committee and District Level Survey Committee by 30.11.2023 [para 96(12)]	Relates to Social Welfare Department, Chandigarh. However, the various other committees has already been constituted by the Social Welfare Department at Sr. No. 1 in the reply.

It is therefore requested that to compliance the order of Hon'ble Supreme Court for Writ Petition (Civil) No.324 of 2020 filed by Dr. Balram Singh Vs union of India & Ors before Supreme Court of India. The necessary approval for Sr. No. 3, 4 & 6 is required for adaptation from the Competent Authority in case of event occurs in future.

DA/-



Executive Engineer,
M.C.P.H. Division No.4,
Chandigarh

Endst. No.....

Dated.....

Copy of the above is forwarded to the Superintending Engineer, M.C.P.H. Circle Chandigarh for kind information please. A copy of meeting notice is also enclosed herewith which is scheduled to be held on 15.12.2023 at 03:00 PM through VC from Conference Room No.627, A Wing, 6th Floor, Shastri Bhawan, New Delhi to discuss the status of implementation of Hon'ble Supreme Court judgment dated 20.10.2023 in Writ Petition (Civil) No. 324 of 2020 filed by Dr. Balram Singh against Union of India and others.

DA/As above

Executive Engineer,
M.C.P.H. Division No.4,
Chandigarh

True copy"

OUT AT ONCE
SUPREME COURT MATTER

SPEED POST

From No.SWD(RA)/MS Act/2023/ 5047

To The Director Social Welfare,
Women & Child Development
Chandigarh Administration

Smt.Yogita Swaroop,
Sr. Economic Adviser,
Government of India,
Ministry of Social Justice & Empowerment,
Pandit Deendayal Antyodaya Bhawan,
CGO Complex, Lodhi Road,
New Delhi-110003.

Dated Chandigarh, the 30/06/23

**Subject:- Regarding Hon'ble Supreme Court Matter of WP(C)
No.324/2020 filed by Dr.Balram Singh Vs. Union of India
& Ors.**

Madam,

I am directed to refer to your DO letter No.U-12012/1/2023-PLAN dated 14.06.2023 regarding reply of UT, Chandigarh in respect of Hon'ble Supreme Court order dated 02.05.2023 passed in WP(C) No.324/2020. filed by Dr.Balram Singh Vs. Union of India & Ors. has been prepared and enclosed as **ANNEXURE** for information, as desired.

Yours faithfully,

Research Officer,
for Director Social Welfare,
Women & Child Development,
Chandigarh Administration

DESPATCHED

//True copy//

278

(APPENDIX-VII)

Details of prosecution ever since M.S.Act, 2013 came into force in each sewer death case

S.No.	Distriot	Name of the Deceased	Date of Death	FIR No./Date and sections	Name(s) of Accused	Current State of Investigation/Prosecution	Amount Paid to their dependents	Date
1	Chandigarh	Happy	01.04.2012	FIR No.30/01.04.2012	Sh.Baljeet Singh	--	Rs.10.00 Lakh	21.04.2012
2	Chandigarh	Satbir	21.08.2014	Nil	Nil	Nil	Rs.10.00 Lakh	--
3	Chandigarh	Dhan Singh	30.05.2015	FIR No.142 dt. 30.05.2015, Police Station-31 U/s 304-A-IPC & Section 9 of The Prohibition of Employment a Manual Scavengers and their Rehabilitation Act 2013.	1. Sukhraj Singh s/o Samon Singh age 40 yrs 2. Jaspal Kaur W/o Sukhraj Singh both r/o # 601 Vill. Dariya Chd Age-37 yrs	Acquitted on 15.12.2017	Rs.10.00 Lakh	06.12.2016
4	Chandigarh	Prem Pal	30.05.2015				Rs.10.00 Lakh	06.12.2016
5	Chandigarh	Asrafi	30.05.2015				Rs.10.00 Lakh	06.12.2016
6	Chandigarh	Sh.Jatinder	28.05.2016	FIR No 164 dated 28.05.16 u/s 304 A IPC & 9 the Prohibition of Employment a Manual Scavengers & their Rehabilitation Act 2013 PS-31, Chandigarh	1.Prithvi Raj Sharma @ Roshani S/o Lehri Ram H No. 437, Sec 46, Chd, 2.KishoriLal S/O Junda Ram H No. 1743, Aman Colony DhanasChd	Put in Court for trial on 20.05.19	Rs.10.00 Lakh	--

True copy!!

279

OUT AT ONCE
SUPREME COURT MATTER

SPEED POST

From No.SWD(RA)/MS Act/2023/ 5047

The Director Soeial Welfare,
Women & Child Development
Chandigarh Administration

To

Smt.Yogita Swaroop,
Sr. Ecopnomic Adviser,
Government of India,
Ministry of Social Justice & Empowerment,
Pandit Deendayal Antyodaya Bhawan,
CGO Complex, Lodhi Road,
New Delhi-110003.

Dated Chandigarh, the 30/06/23

**Subject:- Regarding Hon'ble Supreme Court Matter of WP(C)
No.324/2020 filed by Dr.Balram Singh Vs. Unicu of India
& Ors.**

Madam,

I am directed to refer to your DO letter No.U-12012/1/2023-PLAN dated 14.06.2023 regarding reply of UT, Chandigarh in respect of Hon'ble Supreme Court order dated 02.05.2023 passed in WP(C) No.324/2020, filed by Dr.Balram Singh Vs. Union of India & Ors. has been prepared and enclosed as **ANNEXURE** for information, as desired.

Yours faithfully,

[Signature]
Research Officer,
for Director Social Welfare,
Women & Child Development,
Chandigarh Administration

DESPATCHED

//True copy

286

(APPENDIX-VII)

Details of prosecution ever since M.S.Act, 2013 came into force in each sewer death case

S.No.	Distriot	Name of the Deceased	Date of Death	FIR No./Date and sections	Name(s) of Accused	Current State of Investigation/Prosecution	Amount Paid to their dependents	Date
1	Chandigarh	Happy	01.04.2012	FIR No.30/01.04.2012	Sh.Balject Singh	---	Rs.10.00 Lakh	21.04.2012
2	Chandigarh	Satbir	21.08.2014	Nil	Nil	Nil	Rs.10.00 Lakh	--
3	Chandigarh	Dhan Singh	30.05.2015	FIR No.142 dt. 30.05.2015, Police Station-31 U/s 304-A-IPC & Section 9 of The Prohibition of Employment a Manual Scavengers and their Rehabilitation Act 2013.	1. Sukhraj Singh s/o Samon Singh age 40 yrs	Acquitted on 15.12.2017	Rs.10.00 Lakh	06.12.2016
4	Chandigarh	Prem Pal	30.05.2015	304-A-IPC & Section 9 of The Prohibition of Employment a Manual Scavengers and their Rehabilitation Act 2013.	2. Jaspal Kaur W/o Sukhraj Singh both r/o # 601 Vili. Dariya Chd Age-37 yrs		Rs.10.00 Lakh	06.12.2016
5	Chandigarh	Asrafi	30.05.2015				Rs.10.00 Lakh	06.12.2016
6	Chandigarh	Sh.Jatinder	28.05.2016	FIR No 164 dated 28.05.16 u/s 304 A IPC & 9 the Prohibition of Employment a Manual Scavengers & their Rehabilitaticu Act 2013 PS-31, Chandigarh	1.Prithvi Raj Sharma @ Rcshani S/o Lehri Ram H No. 437, Sec 46, Chd, 2.KishoriLal S/O Junda Ram H No. 1743, Aman Colony DhanasChd	Put in Court for trial on 20.05.19	Rs.10.00 Lakh	--

"The copy" /

281

DEPARTMENT OF SOCIAL WELFARE, WOMEN & CHILD DEVELOPMENT
CHANDIGARH ADMINISTRATION

NOTIFICATION

No.RA/MS Act/2023/ 10308

Dated: 28/12/23

In pursuance of Section 24 of the "Prohibition of Employment as Manual Scavengers and their Rehabilitation Act, 2013", the Administrator, UT, Chandigarh is pleased to constitute a **District Vigilance Committee**, comprising the following, to execute the functions defined under Section-25 of the "Prohibition of Employment as Manual Scavengers and their Rehabilitation Act, 2013" Act in Union Territory of Chandigarh:-

- | | | |
|-----|---------------------------------------------------------------------------------------------------------------|---------------------|
| 1. | District Magistrate
UT, Chandigarh | Chairperson |
| 2. | Medical Officer of Health,
Municipal Corporation, Chandigarh | Member |
| 3. | Sr. Superintendent of Police,
UT, Chandigarh | Member |
| 4. | Sub-Divisional Magistrate (Central)
UT, Chandigarh | Member |
| 5. | Sub-Divisional Magistrate (South)
UT, Chandigarh | Member |
| 6. | Sub-Divisional Magistrate (East)
UT, Chandigarh | Member |
| 7. | Chief Engineer
Municipal Corporation, Chandigarh | Member |
| 8. | Chief Sanitary Inspector
Municipal Corporation, Chandigarh | Member |
| 9. | Sh.Shubham Pawar, ADEN/CDG (by designation)
Northern Railway, Ambala Cantt. | Member |
| 10. | Lead Bank Manager
PNB, Chandigarh | Member Secretary |
| 11. | Director Social Welfare
Chandigarh Administration | Member |
| 12. | Company Secretary
Chandigarh Scheduled Castes Backward Classes
& Min. Fin. Dev. Corpn. Ltd., Chandigarh | |
| 13. | Mr.Subhash Thakur, Head Sewermen (Retd.)
S/o Sh.Bhagwan Singh,
H.No.2348, Sector 38-C, Chandigarh. | Non-Official Member |
| 14. | Mr.Surinder Singh, Head Sewermen (Retd.)
S/o Sh.Ved Parkash, H.No.864, DMC,
Chandigarh. | Non-Official Member |
| 15. | Mr.Karnal, Head Sewermen (Retd.)
S/o Sh.Butta, H.No.1201, Ramdarbar, Ph-I,
Chandigarh. | Non-Official Member |

NITIN KUMAR YADAV
Secretary Social Welfare,
Women & Child Development,
Chandigarh Administration

Dated:26.12.2023

No.RA/MS Act/2023/ 10309

Dated: 28/12/23

A copy is forwarded to PA/DC-cum-District Magistrate, U.T., Chandigarh for information of the DC-cum-Distt. Magistrate, UT, Chandigarh please.

[Signature]
Director Social Welfare,
for Secretary Social Welfare,
Chandigarh Administration.

Dated: 28/12/23

No.RA/MS Act/2023/ 10310

A copy is forwarded to the all concerned Members and Non-Official Members for information and necessary action please.

[Signature]
Director Social Welfare,
for Secretary Social Welfare,
Chandigarh Administration.

Dated: 28/12/23

No.RA/MS Act/2023/ 10311

A copy is forwarded to the Controller, Printing & Stationery, Chandigarh Administration for information with request to publish the said notification in the next Gazette Chandigarh Administration.

[Signature]
Director Social Welfare,
for Secretary Social Welfare,
Chandigarh Administration.

TRUE COPY//
282

DEPARTMENT OF SOCIAL WELFARE, WOMEN & CHILD DEVELOPMENT
CHANDIGARH ADMINISTRATION

NOTIFICATION

No.RA/MS Act/2023/ 10312

Dated: 28/12/23

In pursuance of Rule 11(2), 11(18) & 11(19) of the "Prohibition of Employment as Manual Scavengers and their Rehabilitation Rules, 2013", the Administrator, UT, Chandigarh is pleased to constitute a **District Level Survey Committee**, comprising the following, to monitor and oversee the survey of manual scavengers and insanitary latrines and to execute the functions defined under the "Prohibition of Employment as Manual Scavengers and their Rehabilitation Rules, 2013" in Union Territory of Chandigarh:-

- | | | |
|----|----------------------------------------------------------------------------------------------------------|---------------------|
| 1. | Deputy Commissioner
UT, Chandigarh | Chairperson |
| 2. | Joint Director Social Welfare
Chandigarh Administration | Member Secretary |
| 3. | Joint Commissioner,
Municipal Corporation, Chandigarh | Member |
| 4. | Research Officer,
Economics & Statistical Department,
UT, Chandigarh | Member |
| 5. | Sh.Shubham Pawar, ADEN/CDG (by designation)
Northern Railway, Ambala Cantt. | Member |
| 6. | Mr.Subhash Thakur, Head Sewermen (Retd.)
S/o Sh.Bhagwan Singh,
H.No.2348, Sector 38-C, Chandigarh. | Non-Official Member |
| 7. | Mr.Surinder Singh, Head Sewermen (Retd.)
S/o Sh.Ved Parkash, H.No.864, DMC,
Chandigarh. | Non-Official Member |
| 8. | Mr.Kamal, Head Sewermen (Retd.)
S/o Sh.Butta, H.No.1201, Ramdarbar, Ph-II,
Chandigarh. | Non-Official Member |

NITIN KUMAR YADAV
Secretary Social Welfare,
Women & Child Development,
Chandigarh Administration

Dated: 26.12.2023

No.RA/MS Act/2023/ 10313

Dated: 28/12/23

A copy is forwarded to PA/DC-cum-District Magistrate, U.T., Chandigarh for information of the DC-cum-Dist. Magistrate, UT, Chandigarh please.

Director Social Welfare,
for Secretary Social Welfare,
Chandigarh Administration.

Dated: 28/12/23

No.RA/MS Act/2023/ 10314

A copy is forwarded to the all concerned Members and Non-Official Members for information and necessary action please.

Director Social Welfare,
for Secretary Social Welfare,
Chandigarh Administration.

Dated: 28/12/23

No.RA/MS Act/2023/ 10315

A copy is forwarded to the Controller, Printing & Stationery, Chandigarh Administration for information with request to publish the said notification in the next Gazette Chandigarh Administration.

Director Social Welfare,
for Secretary Social Welfare,
Chandigarh Administration.

11/11/23

DEPARTMENT OF SOCIAL WELFARE, WOMEN & CHILD DEVELOPMENT
CHANDIGARH ADMINISTRATION

NOTIFICATION

No.RA/MS Act/2023/ 10316

Dated: 20/12/23

In pursuance of Section 26 of the "Prohibition of Employment as Manual Scavengers and their Rehabilitation Act, 2013", the Administrator, UT, Chandigarh is pleased to constitute a **State Monitoring Committee**, comprising the following, to execute the functions defined under Section-27 of the "Prohibition of Employment as Manual Scavengers and their Rehabilitation Act, 2013" Act in Union Territory of Chandigarh:-

- | | | |
|-----|-----------------------------------------------------------------------------------------------------------------|---------------------|
| 1. | Adviser to the Administrator
UT, Chandigarh. | Chairperson |
| 2. | Home Secretary
Chandigarh Administration | Member |
| 3. | Secretary Social Welfare,
Chandigarh Administration | Member |
| 4. | Commissioner, Municipal Corporation
-cum-Secretary Rural Development, Chandigarh | Member |
| 5. | Deputy Commissioner
UT, Chandigarh | Member |
| 6. | Director General of Police,
UT, Chandigarh | Member |
| 7. | Representative of National Commission for SC/ST
Chandigarh. | Member |
| 8. | Sh.Aditya Sharma, CDO (Qaz)/CDG (by designation)
-cum-Dy.Director/Heritage
Northern Railway, Ambala Cantt | Member |
| 9. | Lead Bank Manager
PNB, Chandigarh | Member |
| 10. | Director-Social Welfare
Chandigarh Administration | Member Secretary |
| 11. | Mr.Subhash Thakur, Head Sewermen (Retd.)
S/o Sh.Bhagwan Singh,
H.No.2348, Sector 38-C, Chandigarh. | Non-Official Member |
| 12. | Mr.Surinder Singh, Head Sewermen (Retd.)
S/o Sh.Ved Parkash, H.No.864, DMC,
Chandigarh. | Non-Official Member |
| 13. | Mr.Kamal, Head Sewermen (Retd.)
S/o Sh.Butta, H.No.1201, Ramdarbar, Ph-II,
Chandigarh. | Non-Official Member |

NITIN KUMAR YADAV
Secretary Social Welfare,
Women & Child Development,
Chandigarh Administration

Dated:26.12.2023

No.RA/MS Act/2023/ 10317

Dated: 20/12/23

A copy is forwarded to PS/AA for information of the Werthy Adviser to the Administrator, UT, Chandigarh please.

[Signature]
Director Social Welfare,
for Secretary Social Welfare,
Chandigarh Administration.

Dated: 20/12/23

No.RA/MS Act/2023/ 10318

A copy is forwarded to the all concerned Members and Non-Official Members for information and necessary action please.

[Signature]
Director Social Welfare,
for Secretary Social Welfare,
Chandigarh Administration.

Dated: 20/12/23

No.RA/MS Act/2023/ 10319

A copy is forwarded to the Controller, Printing & Stationery, Chandigarh Administration for information with request to publish the said notification in the next Gazette Chandigarh Administration.

[Signature]
Director Social Welfare,
for Secretary Social Welfare,
Chandigarh Administration.

1/True copy//
S

284

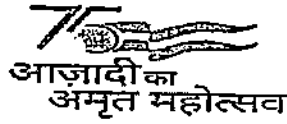

वसुधैव कुटुम्बकम्
ONE EARTH - ONE FAMILY - ONE FUTURE

केंद्र शासित प्रदेश लद्दाख प्रशासन
समाज एवं आदिवासी कल्याण विभाग
संघ राज्य सचिवालय, लद्दाख

THE ADMINISTRATION OF
UNION TERRITORY OF LADAKH,
SOCIAL & TRIBAL WELFARE
DEPARTMENT,
UT Secretariat, Ladakh.

ई-मेल/Email: stw-ladakh@ladakh.gov.in

दूरभाष/Phone No: 01982-258385

Under Secretary to GoI
Ministry of Social Justice & Empowerment
New Delhi.

Subject: Civil Writ Petition (PIL) No. 324 of 2020 In the matter of Dr. Balaram Singh VS Union of India and others pending Before Supreme Court of India- regarding.

Sir,

Kindly refer to letter No. U-12012/01/2023(Plan), dated 02.01.2024, the Action Taken Report on the observations of Hon'ble Supreme Court is reflected below:

Observations of the Hon'ble Supreme Court	Action Taken Report
MS Act, 2013; MS Rule 2013 and guidelines framed by the union are embodied in states/UTs guidelines and directions are applicable to all municipalities and local bodies [para 96(2)]	There are no manual scavengers and insanitary latrines in the municipal limits of two districts as per the report submitted by the Municipal Committees of the two districts. However, under this act, in exercise of the power conferred by section 32 of the Prohibition of Employment as Manual Scavengers and their Rehabilitation Act, 2013 (Act No. 25 of 2013), the Ladakh Administration has designated Administrative Secretary, Social and Tribal Welfare Department, UT Ladakh, as Union Territory Commission for Safai Karamcharis to perform, within the Union Territory of Ladakh, mutatis mutandis, the functions specified in sub-section (1) of section 31 of Act (copy enclosed) and has also nominated Director, Urban Local Bodies, UT of Ladakh, as the UT Level Nodal Officer under Act. (copy enclosed)
Full Rehabilitation (including employment to the next of kin, education to the wards, and skill training) of sewage workers, and those who die [para 96(3)]	Currently there aren't any manual scavengers in Municipal committees of Leh and Kargil. However, the responsibility for rehabilitation if such incidents occur in the future, has been entrusted to the concern District Magistrates of Leh and Kargil.

<p>Payment of compensation with increased amounts i.e., Rs 30 lakhs for sewer deaths. In the event, dependents of any victim have not been paid such amount, the above amount shall be payable to them, hereafter as compensation [para 96 (4)];</p>	<p>No sewer deaths have been reported in the urban areas of UT of Ladakh. However, if such sewer deaths occur in future, this clause will be appropriately considered for compensation, as submitted by the Housing & Urban Development Department of UT Ladakh.</p>
<p>Payment of compensation of Rs. 20 lakhs, in the case of sewer victims suffering disabilities, depending upon the severity of disabilities. Minimum compensation shall not be less than Rs 10 lakhs [para 96 (5)]</p>	<p>There are no manual scavengers as per the survey conducted by Municipal Committee (MC), Leh in January 2021 and Municipal Committee (MC), Kargil in April 2022. Moreover, both the MCs are using modern equipment to ensure the safety of the workers. No sewer death has been reported in the UT. If such sewer death occurs in future, there shall be appropriate compensation as per the Act.</p>
<p>Devise suitable mechanism to ensure accountability, especially wherever sewer deaths occur in the course of contractual or "outsourced" work [para 96 (6)]</p>	<p>The UT Administration through Municipal Committees have taken proper measures to provide protective equipment for the sanitary workers engaged in septic tank cleaning by procured Bandicoot robot, suction machine, rodding machine, and jetting machine to clean the septic tanks. Further, both the MCs have complied with the condition to achieve ODF+ and GFC, wherein, protecting the safety of sanitary workers is one the mandatory conditions. Further, there is a sanitation wing under Municipal Committees, having staff right from Assistant Sanitation officer, Sanitary Inspector, Sanitary Supervisor and Safai-wala with fixed responsibilities. Time to time Training of such Sanitary Workers is also conducted through NGOs and workshops. Additionally, Responsible Sanitation Authority (RSA) & Emergency Response Sanitation Unit (ESRU) established at District Level (copy enclosed). Along with State Level Nodal officer & ULB level nodal officer also has been appointed for National Action for Mechanized Sanitation Ecosystem (NAMASTE) scheme (copy enclosed).</p>
<p>Set up scholarships to ensure that the dependents of sewer victims, (who have died, or might have suffered disabilities) are given meaningful education [para 96 (10)];</p>	<p>Compliance of this clause will be considered after consultation.</p>
<p>Ensure establishment of State Commission for Safai Karamcharis and all Committees mentioned in MS Act, 2013 and MS rules 2013 including State Monitoring Committee, State Level survey</p>	<p>The Ladakh Administration vide S.O 49, dated 14 July, 2023, has designated Administrative Secretary, Social and Tribal Welfare Department, UT Ladakh, as Union Territory Commission for Safai Karamcharis to perform, within the Union Territory of Ladakh, mutatis mutandis, the functions</p>

Committee, District Vigilance Committee and District Level Survey Committee by 30.11.2023 [para 96 (12)].	specified in sub-section (1) of section 31 of Act. (copy enclosed). The State Level Monitoring Committee, District Level Vigilance Committee and Sub-division Level Vigilance Committee are in process of constitution and file is currently with GAD UT Ladakh.
-----------------------------------------------------------------------------------------------------------	---------------------------------------------------------------------------------------------------------------------------------------------------------------------------------------------------------------------------------------------------------------------

Yours sincerely, भवदीय

Encl: A/A

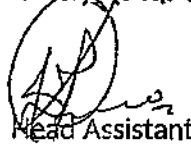
Head Assistant

Social & Tribal Welfare Dept./ समाज एवं आदिवासी कल्याण विभाग

No: M/328/2023-S&TW SEC/6144-50

Dated: 10/01/2024

Copy to:

1. Director, Social and Tribal Welfare Department, UT of Ladakh.
2. Director, Urban Local Bodies UT of Ladakh.
3. Shri S K Srivastwa, Deputy Secretary, Ministry of Social Justice & Empowerment
4. PS to Secretary, Ministry of Social Justice & Empowerment
5. PS to Adv. to the Hon'ble Lieutenant Governor, UT of Ladakh for info. of the Advisor
6. PA to Comm./Secy., Social and Tribal Welfare Department for information of Commissioner Secretary.

//True copy"

↙

287

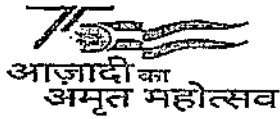

कार्येण सुखव्ययम्
ONE EARTH - ONE FAMILY - ONE FUTURE

F. No. A/246/2021-S&TW SEC-Part(2)/ 3761 - 68

केंद्र शासित प्रदेश लद्दाख प्रशासन
समाज एवं आदिवासी कल्याण विभाग
संघ राज्य सचिवालय, लद्दाख

THE ADMINISTRATION OF
UNION TERRITORY OF LADAKH,
SOCIAL & TRIBAL WELFARE
DEPARTMENT,
UT Secretariat, Ladakh.

ई-मेल/Email: stw-ladakh@ladakh.gov.in

दूरभाष/Phone No: 01982-258365

Notification

Ladakh 14th July, 2023

S.O. 49 In exercise of the power conferred by section 32 of the Prohibition of Employment as Manual Scavengers and their Rehabilitation Act, 2013 (Act No. 25 of 2013), the Administrator/ Hon'ble Lieutenant Governor, Union Territory of Ladakh hereby designate the Administrative Secretary, Social and Tribal Welfare Department, Union Territory of Ladakh, as Union Territory Commission for Safai Karamcharis to perform, within the Union Territory of Ladakh, mutatis mutandis, the functions specified in sub-section (1) of section 31 of Act.

By order of the Hon'ble Lieutenant Governor, Union Territory of Ladakh.

Sd/-

(Padma Angmo) IIS/पद्मा अंगमो,
Commissioner/ Secretary/आयुक्त/सचिव
Social & Tribal Welfare Dept./ समाज एवं आदिवासी कल्याण विभाग

Copy to:

1. All Administrative Secretaries, UT of Ladakh.
2. Deputy Commissioner/CEO, LAHDC, Leh & Kargil.
3. Director, Social & Tribal Welfare, UT of Ladakh.
4. Director, Urban Local Bodies, UT of Ladakh.
5. OSD to Hon'ble Lt. Governor, UT of Ladakh as for kind info. of Hon'ble Lt. Governor, UT of Ladakh.
6. PS to Adv. to Hon'ble Lt. Governor, UT of Ladakh for info. of Advisor, UT of Ladakh.
7. PA to Comm./Secy., S&TWD for information of Comm./Secy.

Stanzin Shakya (Ph.D.) स्तंज़िन शाक्य

OSD to Commissioner/ Secretary/आयुक्त सचिव के ओएसडी
Social & Tribal Welfare Dept./ समाज एवं आदिवासी कल्याण विभाग

//True copy//

288



सत्यमेव जयते

समृद्धि
ONE PARTH - ONE FAMILY - ONE FUTURE

संघ राज्य प्रशासन, लद्दाख

THE ADMINISTRATION OF
UNION TERRITORY OF LADAKH

सामान्य प्रशासन विभाग

GENERAL ADMINISTRATION
DEPARTMENT

F.No: A/91/2021-GAD SEC-Part(1)

ई-मेल/email:pstocomsecuti@gmail.com
gad.utladakh@ladakh.gov.in

यूटी सचिवालय/UT Secretariat

लेह/Leh, Dated: - 17.03.2023

Subject: Nomination of UT Level Nodal Officer under 'The Prohibition of
Employment as Manual Scavengers and their Rehabilitation Act 2013'.Ref. DO Letter No. U-12012/01/2023-Plan dated. 2nd March 2023 from
Secretary MoS J&E reg. Hon'ble Supreme Court judgment and directions
dated: 22.02.2023.

Order No: - 69-LA(GAD) of 2023

Dated:- 17. 03.2023

Sanction is hereby accorded to the nomination of the Director, Urban Local
Bodies, UT of Ladakh, as the UT Level Nodal Officer under the 'The Prohibition of
Employment as Manual Scavengers and their Rehabilitation Act 2013'.The Officer shall coordinate with the Nodal Officer, MoSJ&E, Gei, for the all
issues related to the aforementioned Act and directions of the Hon'ble Supreme
Court thereof.

By the order of Competent Authority.

Sd/-

(Y.M. Maraikar) IAS

Administrative Secretary

General Administration Department

Copy to the:

1. Principal Secretary H&UD Department, Ladakh.
2. Commissioner/ Secretary S&TW Department, Ladakh. The UO file No. M/328/2023-S&TW SEC is also returned herewith.
3. Shri. S.K. Srivastava Deputy Secretary to GoI, Nodal Officer, MoSJ&E.
4. Smt. Zahida Bano, JKAS, Director, Urban Local Bodies, Ladakh.
5. Private Secretary to Advisor to Hon'ble Lt. Governor for Information of Advisor to Hon'ble Lt. Governor, UT Ladakh.
6. E-office/Order file

Sonam

Digitally signed by
Sonam Chhosdon

Chhosdon

Date: 2023.03.17
17:21:12 +05'30'

(Sonam Chhosdon/ सोनम छोसडोन)

Deputy Secretary/ उप सचिव

General Administration Department

//True copy//

289 ✓

1. Deputy Commissioners, Leh and Kargil.
2. Director Urban Local Bodies, Ladakh.
3. OSD to Hon'ble Lieutenant Governor, UT, Ladakh for kind information of Hon'ble Lieutenant Governor.
4. OSD to Advisor to Hon'ble Lieutenant Governor for kind information of the Advisor.
5. Executive Officer, MC, Leh and Kargil.
6. Stock file.

Under Secretary,
Housing & Urban Development,
Department, UT, Ladakh.

//True copy//





लक्षद्वीपप्रशासन/ LAKSHADWEEP ADMINISTRATION
सामाजिककल्याणओरजनजातीयमाम लेकेनिदेशालय
(Directorate of Social Welfare & Tribal Affairs)
कवरत्ती/Kavaratti - 682 555

F.No.14/3/2019-SWTA/

Date: // .01.2024

To,

The Deputy Secretary to the Govt. of India
Ministry of Social Justice & Empowerment
Department of Social Justice & Empowerment
B-2 Ground Floor
Pt. Deendayal Antyodaya Bhawan
New Delhi-110 003

Subject:-SWTA-UTL- Furnishing of information on writ petition (civil) No. 324 of 2020
filed by Dr. Balram Sing vs Union of India & Ors Supreme Court of India-
Regarding-Reg.

Reference:- F.No.U-i2021/1/2023-Plan Dated 14.11.2023.

Sir,

Kindly see to the reference mentioned above regarding writ petition (Civil) No. 324 of
2020 filed by Dr. Balram Sing vs Union of India & Ors Supreme Court of India. Therefore, the
details pertaining to UT of Lakshadweep Administration are enclosed for further necessary
action.

Yours faithfully

Encl: As above

Special Secretary

(Social Welfare and Tribal Affairs)&

State Commissioner of PwDs

Phone No. 2314, Email ID: lk-dsw@nic.in

//True copy//

292

«Угос елтл»

लक्षदीप



भारत सरकार

349

लक्षद्वीपप्रशासन/ LAKSHADWEEP ADMINISTRATION
सामाजिककल्याणओरजनजातीयमाम लेकेनिदेशालय
(Directorate of Social Welfare & Tribal Affairs)
कवरत्ती/Kavaratti - 682 555

F.No.14/I6/2023-SWTA/

दिनांक: 05.01.2024

सेवामे,

Chief Executive Officer
District Panchayat
Kavaratti

विषय:-SWTA-UTL- Hon'ble Supreme Court direction for compliance of the order dated 20.10.2023 related to the Prohibition of Employment as Manual Scavengers and their Rehabilitation Act 2013. -Reg.

- संदर्भ:- 1. F.No.U-12021/1/2023-Plan Dated 14.11.2023.
2. Prohibition of Employment as Manual Scavengers and their Rehabilitation Act 2013 & Rules.

महोदय,

Kindly see to the reference mentioned above regarding Writ petition (Civil) No. 324 of 2020 filed by Dr. Balram Sing vs Union of India & Ors in Hon'ble Supreme Court of India and Hon'ble court vide order dated 20.10.2023 has directed for compliance of the observations communicated vide F.No. U-12021/1/2023-PLAN Dated 14.11.2023.

Therefore, you are hereby requested to comply the provisions of Prohibition of Employment as Manual Scavengers and their Rehabilitation Act 2013 and rules thereof and guidelines framed by Union of India/ UT of Lakshadweep in your jurisdiction and undertake the survey of manual scavenger in compliance of section 14 of the Prohibition of Employment as Manual Scavengers and their Rehabilitation Act 2013 and send compliance report within 15 days so that it could be submitted to Hon'ble Supreme Court of India.

Encl : As above

भवदीय,

5.1.24

Tanvir Ahmad, DANICS
Special Secretary cum Director
(Social Welfare and Tribal Affairs)&
State Commissioner of PwDs
Phone No. 2314, Email ID: lk-dsw@nic.in

Copy to:

1. PA to the Secretary (SW&TA)
2. PA to the Secretary (Panchayat)
3. Director, Panchayat

//TRUE COPY//

236

SPEED POST

MOST URGENT COURT CASE

GOVERNMENT OF PUDUCHERRY Annexure IV Q
AD WELFARE AND ST WELFARE SECRETARIAT

No.3439/ADW&STW/G5/MS-ATR/Wel/SCW-II/2023-24

dt.22.12.2023

To

✓ The Deputy Secretary,
Ministry of Social Justice and Empowerment,
Department of Social Justice and Empowerment,
B-2, Ground Floor,
Pt. Deendayal Antyodaya Bhawan,
CGO Complex,
New Delhi - 110 001.
Tele No. 011 24369841.

Sir,

Sub: ADW&STWD - The Prohibition of Employment as Manual Scavengers and their Rehabilitation Act, 2013 - Supreme Court Judgement on the Writ Petition No.324/2020 of Dr. Balram Singh, Vs Union of India & Ors. - Action taken Report - Submitted - Reg.

Ref: Your Lt.No.U-12021/1/2023-PLAN, dt.14.11.2023.

&&*

With reference to the subject mentioned above, I am directed to submit the action taken report for implementation of the "Prohibition of Employment as Manual Scavengers and their Rehabilitation Act, 2013 (MS Act, 2013), In the U.T. of Puducherry, based on the direction given by the Hon'ble Supreme Court in the Judgement of Writ Petition (Civii) Nos.324 of 2020 filed by Dr. Balram Singh, Vs Union of India & Ors. in the prescribed Annexure.

Yours faithfully,

S. e.

(S. MURUGESAN)
UNDER SECRETARY (ADW&STW)

Encl.: As above.

Copy submitted to:

1. The Chief Secretary to Govt., Chief Secretariat, Puducherry.
2. The Secretary to Govt. (Social Welfare), Chief Secretariat, Puducherry.
3. The Secretary to Govt. (Social Welfare), Chief Secretariat, Puducherry.

//True copy//
297

ANNEXURE

Sl. No.	Action Taken Points on the direction of Hon'ble Supreme Court	Reply furnished
1	<p>The Union should take appropriate measures and frame corporations, railways, cantonments, as well as agencies under its control, to ensure that manual sewer cleaning is completely eradicated in a phased manner, and also issue such guidelines and directions as are essential, that any sewer cleaning work outsourced, or required to be discharged, by or through contractors or agencies, do not require to be discharged, by or through contractors or agencies, do not require individuals to enter sewers, for any purpose whatsoever.</p>	<p>The Public Health Division of Public Works Department is maintaining the UGD in Union Territory of Puducherry. The sewer lines and its appurtenances are maintained through out sourcing by calling of tenders. In the tender a special condition for maintenance of sewer was already given ie. "The Maintenance work has to be carried out using necessary tools and plants only. Manual method of cleaning the Intercepting Chambers, manholes and other appurtenances of sewerage system is strictly prohibited".</p> <p>Also the list of essential compulsory equipments and machineries for carrying out the drainage maintenance work with safety and to keep the environment hygienic.</p> <ol style="list-style-type: none"> i. Tools and Plants and Safety Equipments ii. Jetting cum Suction Machine/Jetting and suction machine iii. Sewer Rods iv. Rodding Machine v. Scrapper vi. Manila Rope vii. Other hand tools viii. Protective glove ix. Heavy duty coat x. Knee high safe boots xi. Gasmasks xii. Portable lighting equipments xiii. Gas test equipments xlv. Inhalator xv. First Aid equipments xvi. Manually operated desilting Machine. <p>One MoA (Memorandum of Agreement) has been signed between Government of Puducherry and NSKFDC, New Delhi for procurement of Sewer maintenance Machineries (Special Equipments) on 20.12.2023. This Agreement has been signed to purchase the special equipments for cleaning the sewer lines to eradicate manual scavenging.</p>

//True copy//

Contd..p..2/-

S.L.

Sl. No.	Action Takeo Points on the direction of Hon'ble Supreme Court	Repiy furnished
2	All States and Union Territories are likewise, directed to ensure that all departments, agencies, corporations and other agencies (by whatever name called) ensure that guidelines and directions framed by the Union are embodied in their own guidelines and directions; the states are spccifically directed to ensure that such directions are applicable to all municipalities, and local bodies functioning within their territories;	Pertaining to Govt. of India. Necessary action will be taken once guidelincs is issued by the Govt. of India.
3	The Union, State and Union Territories are directed to ensure that full rehabilitation (including employment to the next of kin, education to the wards, and skill training) measures are taken in respect of sewage workers, and those who die;	For the rehabilitation of the sewage workers this division had conducted a programme of one day workshop on 20.12.2023 as "Capacity Building for Sanitary workers under Municipality / LAD and sewer cleaners who are involved in sewer cleaning system. Details of rules and regulations, provision for rehabilitation and safety to sanitary workers are clearly explained to the participants.
4	The court hereby directs the Union and the States to ensure that the compensation for sewer deaths is increased (given that the previous amount fixed. i.e., Rs.10 lakhs) was made applicable from 1993. The current equivalent of that amount is Rs.30 lakhs. This shall be the amount to be paid, by the concerned agency, i.e., the Union, the Union Territory or the State as the case may be. In other words, compensation for sewer deaths shall be Rs.30 lakhs. In the event, dependents of any victim have not been paid such amount, the above amount shall be payable to them. Furthermore, this shall be the amount to be hereafter paid, as compensation.	Guidelincs has been framed and sent for consideration to the Government for amending the rules in compliance with the Judgement.
5	Likewise, in the case of sewer victims snffering disabilities, depending upon the severity of disabilities, compensation shall be disbursed. However, the minimum compensation shall not be less than Rs.10 lakhs. If the disability is permanent, and renders the victim economically helpless, the compensation shall not be less than Rs.20 lakhs. 11/400 610711	

Sl. No.	Action Taken Points on the direction of Hon'ble Supreme Court	Reply furnished
6	<p>A) The appropriate government (i.e., the Union, State or Union Territories) shall devise a suitable mechanism to ensure accountability, especially wherever sewer deaths occur in the course of contractual or "outsourced" work. This accountability shall be in the form of cancellation of contract, forthwith, and imposition of monetary liability, aimed at deterring the practice.</p>	<p>Under the Contract Labour (Regulation and Abolition) Act, of 1970, every establishment in which twenty or more workmen are employed or were employed on any day of the preceding twelve months as contract labour as per Section 5 and to which establishment this Act applies, Principal Employer must register before the Registering Authority and the names of the contractor through whom the workers are engaged.</p> <p>On registration, the contractors must obtain the Licence before the Licencing Authority in terms of sub-section (1) Section 12 of the Act and a licence under sub-section (1) may contain such conditions including conditions as to hours of work, fixation of wages and other essential amenities in respect of contract labour.</p> <p>As per Section 14, the Licencing Officer may revoke or suspend the licence if the licence granted under Section 12 has been obtained by misrepresentation or suppression of any material fact, or the holder of a licence has, without reasonable cause, failed to comply with the conditions subject to which the licence has been granted or has contravened any of the provisions of this Act or the rules made thereunder:</p> <p>As per Section 24, If any person contravenes any of the provisions of this Act or of any rules made thereunder for which no other penalty is elsewhere provided, he shall be punishable with imprisonment for a term which may extend to three months, or with a fine which may extend to one thousand rupees, or with both.</p> <p>Further, the Outsourcing agencies engaged in such works will be monitored for strict compliance with the Contract Labour (Prohibition and Regulation Act), 1970 for Registration of the Principal Employer and the Licence of the contractors.</p>

Contd...p..4/-

//True copy//

300

S.L

True copy

Sl. No.	Action Taken Points on the direction of Hon'ble Snpreme Court	Reply furnished
	<p><i>B) The Union shall devlce a model contract, to be used wherever contracts are to be awarded, by it or its agencies and corporations, in the concerned enactment, sueh as the Contract Labour (Prohibition and Regnlation Act), 1970, or any other law, which mandates the standards – in conformity with the 2013 Act, and rules, are strictly followed, and In the event of any mishap, the agency would lose its contract, and posslby blacklisting. This model shall also be used by all States and Union Territories.</i></p>	<p>No such model contract has been issued by the Ministry of Labour and Employment.</p> <p>According to the Standard Operating Procedure (SOP) for Cleaning of Sewers and Septic Tanks issued by the Ministry of Housing and Urban Affairs, an Individual shall always hire/employ the cleaning workers only through their ULBs or Authorized Agencies/designated agencies by ULB. The ULBs and the Authorized Agencies/designated agencies by ULB will be inspected for any violations of the provisions of the Prohibition of Employment as manual scavengers and their Rehabilitation Act, 2013 and appropriate action will be taken to cancel the contract.</p> <p>The Authority under the Employees Compensation Act will adhere to the directions issued by the Hon'ble Supreme Court while passing the Award on such cases for deaths/accidents.</p>

11/29/00 09:17:11

301

True copy!! Contd..p..5/-
J. L.

Sl. No.	Action Taken Points on the direction of Hon'ble Supreme Court	Reply furnished
7	The Union shall device a model contract, to be used wherever contracts are to be awarded, by it or its agencies and corporations, in the concerned euactment, such as the Contract Labour (Prohibition and Regulation Act), 1970, or any other iaw, which mandates the standards – in conformity with the 2013 Act, and ruiels, are strictly followed, and in the event of any mishap, the ageucy would lose its contract, and possibly blacklisting. This model shall also be used by all States and Union Territories.	Pertaining to Govt. of India. Necessary action will be taken once guidelines is issued by the Govt. of India
8	The NCSK, NCSC, NCST are the Secretary, Union Territory of Social Justice and Empowerment, shall, within 3 months from today, draw modalities for the conduct of a National Survey. The Survey shall be ideally conducted and completed in the next one year.	
9	To ensure that the survey does not suffer the same fate as the previous ones, appropriate models shall be prepared to educate and train all concerned committees.	
10	The Union, State and Union Territories are hereby required to set up scholarships to ensure that the dependents of sewer victims, (who have died, or might have suffered disabilities) are given meaningful education.	Through the National Scholarship Portal (NSP), Scholarships are provided to the dependents of Manual Scavengers sewer victims under Pre-Matric Scholarship[component-II] irrespective of caste.
11	The National Legal Services Authority (NALSA) shall also be part of the consultations, toward framing the aforesald policies. It shall also be involved, in co-ordination with state and district legal services committees, for the planning and implementation of the survey. Furthermore, the NALSA shall frame appropriate modeis (in the ight of its experience in reiation to other modeis for disbursement of compensation to victims of crime) for easy disbursement of compensation <i>WJ SUTTA</i>	Pertaining to Govt. of India. Necessary action will be taken once guidelines is issued by the Govt. of India

//True copy//

Contd..p.6/-

✓
302

SM

Si. No.	Action Taken Points on the direction of Hon'ble Supreme Court	Reply furnished
12	The Union, State and Union Territories are hereby directed to ensure co-ordination with all the commissions (NCSK, NCSC, NCST) for setting up of state level, district level committees and commissions, in a time bound manner. Furthermore, constant monitoring of the existence of vacancies and their filling up shall take place.	State Level, District Level and Sub-Divisional Level Monitoring Committee were already being constituted. Further, proposal was already sent to Govt. for constituting the State Level Survey Committee & District Level Survey Committee within 1 month of time.
13	NCSK, NCSC, NCST and the Union government are required to co-ordinate and prepare training and education modules, for information and use by district and state level agencies, under the 2013 Act.	Pertaining to Govt. of India. Necessary action will be taken once guidelines is issued by the Govt. of India.
14	A portal and a dashboard, containing all relevant information, including the information relating to sewer deaths, and victims, and the status of compensation disbursement, as well as rehabilitation measures taken, and existing and available rehabilitation policies shall be developed and launched at an early date.	NIC has been asked to develop a portal and a dashboard, containing all relevant information, including the information relating to sewer deaths, and victims, and the status of compensation disbursement, rehabilitation measures taken etc. within 3 months of time.

S.W
(S. MURUGESAN)
UNDER SECRETARY (ADW&STW)

True copy

Annexure -TV -R

GOVERNMENT OF ODISHA
ST & SC DEVELOPMENT, M & BCW DEPARTMENT

No. 1559 /SSD, dated:- Bhubaneswar, the 19th January, 2024
STSCD-SCP-MEET-0003-2021

From

Sri Laxman Kumar Mallick,
Director, SC Welfare.

To

The Deputy Secretary to Govt. of India
B-2, Ground Floor, Pt. Deendayal Antyodaya Bhawan,
CGO Complex, New Delhi-110003
Email: shivastwa.sk@nic.in & manojik.jha@nic.in

Sub:- Compliance to the direction of Hon'ble Supreme Court in Writ Petition Civil No. 324/2020 filed by Dr. Balarama Singh Vs. Union of India & others.

Sir,

With reference to your letter No.U12012/01/2023(plan) dt.15.12.2023 on the subject cited I am directed to send herewith necessary compliance and the action taken report on the direction of the Hon'ble Supreme Court in Writ Petition Civil No.324/2020 filed by Dr.Balarama Singh Vs. Union of India & others for necessary action at your end. Further the undersigned is the Nodal Officer on behalf of ST&SC Development M&BCW Department, Govt of Odisha for the above Supreme Court Write Petition.

The contact details are as follows;

Name : Sri Laxman Kumar Mallick
Designation: Director, SC Welfare
Mobile No : 9437179399
Email : lkmallick.67@gmail.com

Yours faithfully,

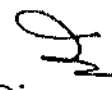
Director, SC Welfare.

True copy
18900 01/1/24

Memo No. 1560 /SSD Date. 19.01.2024

Copy forwarded to the OSD to the Chief Secretary with reference to their OSWAS diary No.45094 dtd.18.11.2023 for kind information of the Chief Secretary.

[Signature]
Director, SC Welfare. 19/1/2024

//True copy//
305

STATUS OF IMPLEMENTATION OF THE VARIOUS PROVISION OF THE PROHIBITION OF EMPLOYMENT AS MANUAL SCAVENGERS AND THEIR REHABILITATION ACT 2013 BY GOVT OF ODISHA

Ref: (1) Judgement dated 20.10.2023 of Hon'ble Supreme Court passed in Writ Petition (Civil) No. 324 /2020 filed by Dr Balram Singh vrs Union of India & Ors. in their judgement dated 20.10.2023

(2) Letter No. U-12021/1/2023-PLAN dated 14.11.2023 of the Ministry of Social Justice and Empowerment

Hon'ble Supreme Court in their order dated 20.10.2023 passed in WP (C) No 324/ 2020 Dr Balram Singh vrs Union of India & Ors have directed all States/UTs to take necessary action in compliance of their observation. The observations communicated in their letter No. U-12021/1/2023-PLAN dated 14.11.2023 and action already taken /proposed thereon are reproduced below:

Sl. No.	Observation of Hon'ble SC	Status of Compliance
1	MS Act, 2013; MS Rules, 2013 and guidelines framed by the Union are embodied in States/UTs guidelines and directions are applicable to all Municipalities and local bodies [Para 96(2)]	<p>Key initiatives already taken by the State Government which subsumes compliance with the aforesaid directions of Hon'ble Supreme Court are reproduced below:</p> <p>Following enactment of Prohibition of Employment as Manual Scavenger and their Rehabilitation Act, 2013 (the Act) and notification of the Rules thereunder, important Notifications /instructions/advisories issued by the State Government for implementing the provisions of the Act. are enumerated below:</p> <p>(a) The ST & SC Development, Minorities & Backward Classes Welfare Department have, vide Notification No.7462 dated 17.04.2017 issued u/s 7 of the Act, prohibited manual scavenging and employment of any person in such activities. The said notification has been circulated among all Urban Local Bodies by H&UD Department Govt of Odisha Letter No.9321 dated 28.04.2017 for strict enforcement of prohibition norms. ULBs were instructed vide letter No. 23449 dated 17.10.2017 to undertake a special drive for enforcing prohibition and bringing to book employers / contractors forcing workmen to perform manual scavenging ,</p> <p>(b) On the advice of the Central Monitoring Committee constituted under the Act, all ULBs and contractors have been asked vide Department (H&UD) Lt No.479 dated 06.01.2018 to (i) adopt mechanical means to clean septic tanks and sewers, (ii) incorporate suitable clauses in the tender document</p>

True copy
 306

		<p>mandating issue of safety gear and equipment to the workmen engaged in sanitation operations and ensuring use of safety equipment. (iii) incorporate a condition in the tender document binding the contractor to pay a compensation of Rs.10 lakh in addition to compensation paid by the state government in case of death of a worker while cleaning septic tank and sewers without safety gear and devices. (iv) identify persons servicing erstwhile insanitary latrines (presently converted to sanitary latrines) and include them in the list of identified manual scavengers. Revision as per the subsequent orders of the Hon'ble Supreme court has already been made and explained in subsequent paras.</p> <p>(c) The Manual on Sewerage and Sewage Treatment System 2013 published by the MoHUA and the Standard Operating Procedure for Cleaning of Sewers and Septic Tanks, 2018 brought out by the CPHEEO on the World Toilet Day on 19.11.2018 have been circulated among the ULBs for strict enforcement vide Lt No.5303 dated 08.03.2019 to eliminate manual scavenging and reduce occupational hazards.</p> <p>(d) On the advice of the MoHUA, Emergency Response Sanitation Units have been set up in all the urban local bodies vide Notifications No.2116 dated 27.01.2020, Notification No.19930 dated 22.12.2020 and Notification No. 1712 dated 20.01.2023. Deputy Commissioners of the Corporations and Executive Officers of Municipalities and NACs have been declared as Responsible Sanitation Authorities u/s 18 of the Act to head ERSU. A detailed advisory on constitution and functioning of ERSU, roles and responsibilities of individual members of the Unit, role of the PSSOs and Sanitation Workers, PPE, safety equipment and other mechanical appliances required for undertaking various cleaning operation, safety norms / precautions to be observed, end-to-end procedure to be followed for handling emergency sanitation requests, creating public awareness and redressal of public grievances etc have been circulated among ULBs vide this Department Letter No.9363 dated 07.05.2021 for guidance and compliance.</p> <p>(e) The State Government, on its own have introduced a dedicated scheme, namely "Garima" for the welfare of the Core</p>
--	--	------------------------------------------------------------------------------------------------------------------------------------------------------------------------------------------------------------------------------------------------------------------------------------------------------------------------------------------------------------------------------------------------------------------------------------------------------------------------------------------------------------------------------------------------------------------------------------------------------------------------------------------------------------------------------------------------------------------------------------------------------------------------------------------------------------------------------------------------------------------------------------------------------------------------------------------------------------------------------------------------------------------------------------------------------------------------------------------------------------------------------------------------------------------------------------------------------------------------------------------------------------------------------------------------------------------------------------------------------------------------------------------------------------------------------------------------------------------------------------------------------------------------------------------------------------------------------------------------------------------------------------------------------------------------------------------------------------------------------------------------------------------------------------------------------------------------------------------------------------------------------------------------------------------------------------------------------------------------------------------------------------------------------------------------------------------------------------------------------------------------------------------------------------------------------------------------------------------------------------------------------------------------------------------------------------

True copy
307
11/05/2021

		<p>Sanitation Workers who are exposed to faecal matter while working in hazardous circumstances. Their safety, security and dignity are the core concerns which are sought to be addressed through the said scheme. The strategy adopted under the scheme include development and enforcement of safety standards, (2) institutionalisation of safe sanitation practices. (3) making such workers financially sound. Important steps taken so far include – (1) formulation of SOP for regulation of hazardous cleaning operations (2) mandatory provision of safety equipment for the Core Sanitation Workers by the employer; (3) provision for better wages by including them in the skilled categories. (4) providing allowance in consideration of the risks associated with their work, (5) providing disablement compensation available under the ESI scheme. Other welfare benefits include provision of mobile set, mobility support and grant for construction of pucca house, capacity building, free medical care and education grant for covering expenses upto post-graduate degree courses.</p>
2	<p>Full rehabilitation (including employment to the next of kin, education to the wards, and skill training) of sewage workers and those who die [Para 96(3)]</p>	<p>Based on the survey held in the year 1997-98, 35049 number of identified scavengers and their dependants have been rehabilitated under the National Scheme for Liberation and Rehabilitation of Scavengers (NSLRS). Of the scavengers identified, 15260 were rehabilitated and the rest 6979 were imparted skill development training.</p> <p>Repeated surveys were taken up at different periods of time at the instance of the Govt of India. Surveys were conducted in 2006-07 followed by re-census in 2011 and again in 2013 with a view to rehabilitating them under the Self Employment Scheme under Rehabilitation of Manual Scavengers (SRMS). During the period from 1992-93 till March, 2006, 14077 nos of identified persons have been rehabilitated under the said scheme. After introduction of the PEMS Act, 2013, 237 identified manual scavengers (data uploaded in the website www.mssurvey.nic.in) have been rehabilitated under NSRLS. One time cash assistance @ Rs.40000/- has been provided to 230 manual scavengers. Subsidised loan has been provided to 98 identified manual scavengers and 22</p>

True copy
30/8

		dependents for their self-employment through income generating projects. Skill development training has been imparted to 58 eligible dependents to make them eligible for self employment / employment.
3	Payment of compensation with increased amount i.e. Rs.30 lakhs for sewer death. In the event, dependents of any victim has not been paid such amount, the above amount shall be payable to them, hereafter as compensation, [Para 96(4)]	<p>Pursuant to the orders dated 27.03.2023 of Hon'ble Supreme Court in WP (C) No.324/2020 filed by Dr Balram Singh vrs Others, the State Government in H&UD Department have enhanced the amount of compensation payable to the families of the sewer victims as follows:</p> <p>In the event of sewer death (death during sewer/ septic tank cleaning) the compensation amount shall be Rs.30.00 lakh.</p> <p>Relevant Notification No.1233 dated 12.01.2024 issued by the State Government in H&UD Department is enclosed.</p>
4	Payment of compensation of Rs.20 lakhs, in the case of sewer victims suffering disabilities, depending upon the severity of disabilities. Minimum Compensation shall not be less than Rs.10 lakhs [Para 96(5)]	<p>Vide Notification No.1233 dated 12.01.2024 issued by the State Government in H&UD Department pursuant to the orders dated 27.03.2023 of Hon'ble Supreme Court in WP(C) No.324/2020 filed by Dr Balram Singh vrs Others, the following structure of compensation in the case of disability has been fixed:</p> <p>(a) If the disability is permanent, total and renders the victim economically helpless, the amount of compensation shall not be less than Rs.20.00 lakh</p> <p>(b) If the disability is partial but permanent, the amount of compensation shall not be less than Rs.15.00 lakh</p> <p>(c) If the disability is temporary, the amount of compensation shall not be less than Rs.10.00 lakh</p>
5	Devise suitable mechanism to ensure accountability, especially wherever sewer deaths occur in the course of contractual or "outsourced" work [Para 96(6)]	<p>Sections-8 and Section-9 of the PEMSAR Act provide for imposition of penalty and / or fine for contraventions of the provisions under Section-5, Section-6 or Section-7 of the Act.</p> <p>In order to enforce compliance by the PSSOs, the State Government have framed a model agreement to be signed between the ULB / Agency and the PSSO. Para 6 and 7 of the model agreement provides for imposition of fines / penalty for violation of the contract terms or non-compliance with the provisions of the PEMSAR Act, 2013. Besides, Para 9 of the model agreement provides for termination of</p>

True copy
309

		<p>contract / agreement for violation of the provisions of the Act or other contractual obligations spelt out therein. All ULBs and para-statal agencies employing PSSOs for cleaning and maintenance of sewer systems and septic tanks have been directed to rescind the existing agreements and replace them with the new contract as per the prescribed model agreement vide this Department Letter No.12076 dated 13.06.2023. As part of the model agreement, the PSSOs are required to give an undertaking in prescribed form to the effect that it has understood the contents of various guidelines, advisories, SOPs notifications issued by the MoHUA and the State Government in matters connected with safe cleaning and maintenance of sewer and septic tanks and that non-adherence to safety protocols will attract punishment under the Act. For monitoring registration of offences under the Act, district level / sub-divisional level Vigilance Committees have been notified by the ST, SC Dev Department vide Notification No.22232 dated 20.12.2019.</p>
6	<p>Set up scholarships to ensure that the dependents of sewer victims, (who have died or might have suffered disabilities) are given meaningful education [Para 96(10)]</p>	<p>As already stated in Sl.1(e) above, the State Government has introduced a dedicated scheme "Garima" for the welfare of the Core Sanitation Workers and their families. The scheme provides for educational grants to the children of the Core Sanitation Workers covering the cost of their tuition fees, hostel and ancillary expenses relating to education up to post graduate degree courses. Further, State Govt is providing scholarship to all the SCs/ST's students of the State.</p>
7.	<p>Ensure establishment of State Commission of Safai Karmacharis and all Committees mentioned in MS Rules, 2013 including State Monitoring Committee, State Level Survey Committee, District Vigilance Committee and District Level Survey Committee by 30.11.2023 [Para 96(t2)]</p>	<p>The State Govt vide ST & SC Development, M&BCW Department Notification No.12982 dated 04.07.2023 declared the Managing Director, OSFDC as State Authority to monitor implementation of the MS Act in the State and also constituted State Level Monitoring Committee, State Level Survey Committee, District Level Survey Committee vide Notification No.18644 dt 17.07.2014 and District Vigilance Committee & Sub-Divisional Level Vigilance Committee vide Notification No.22232/SSD dt.21.12.2019</p>

//True copy//

310



Government of Odisha
Housing & Urban Development Department

File No. HUD-SANT-CASEOP-0003-2023 No. 1233 /HUD, Dated 12-01-2024

NOTIFICATION

Pursuant to the order dated 27.03.2014 of the Hon'ble Supreme Court passed in Contempt Petition No.132/2012 arising out of WP(C) No.583/2003, the amount of compensation payable to the family of the deceased in the event of death while cleaning sewers, was fixed at Rs. 10.00 lakh each. Now, Hon'ble Supreme Court, in their judgement dated 23.10.2023 pronounced in WP(C) No.324/2020 filed by Dr Balram Singh vrs Others, have directed the states to ensure that the compensation amount payable in the event of sewer deaths is increased to Rs. 30 lakh and in case of sewer victims suffering disabilities, the minimum compensation amount shall not be less than Rs 10 lakhs in any case. If, however, the disability is permanent and renders the victim economically helpless, the compensation amount shall not be less than Rs 20 lakhs.

Now, therefore, in obedience to the judgement dated 23.10. 2023 of Hon'ble Supreme Court, Government have been pleased to enhance the amount of compensation payable in the manner as specified below:

(a) In the event of sewer death (death during sewer/ septic tank cleaning) , the compensation amount shall be Rs 30 lakhs;

(b) (i) For the purpose of determining the amount of compensation to the victims of sewer and septic tank accidents, classification of injuries as per Schedule I of the EC Act, 1923 i.e., " Permanent total disablement", "Permanent partial disablement" and "Temporary disablement" shall be adopted.

(ii) In case accidents occur while undertaking sewer / septic tank cleaning which render the victim permanently total disabled and economically helpless, the amount of compensation shall not be less than Rs 20 lakhs and shall be inclusive of payments due and admissible under EC Act.

(iii) In case of accidents attributable to sewer/ septic tank cleaning leading the victim to permanent partial disablement, the amount of compensation shall not be less than Rs 15 lakhs and shall be inclusive of payments due and admissible under EC Act.

(iv) In case of accidents attributable to sewer/ septic tank cleaning leading the victim to temporary disablement, the amount of compensation shall not be less than Rs 10 lakhs and shall be inclusive of payments due and admissible under EC Act.

(v) In case, the quantum of compensation as specified in (ii), (iii) and (iv) above are different from what is admissible under the EC Act, the victim shall be entitled for the

Final copy //
311

higher amount.

(v) In case the amount of compensation as per the above specifications (ii, iii and iv) becomes more than the amount admissible under EC Act, the differential amount shall be met from the Corpus Fund set up under the scheme "Garima".

(c) The rates of compensation as specified at (a) and (b) above shall be applicable with effect from 20.10.2023 i.e., from the date of the judgement of Hon'ble Supreme Court pronounced in WP(C) No.324/2021. However in the event dependents of any victim have not been paid such amount, the above amount shall be payable to them.

ORDER

Ordered that the Notification be published in the Extraordinary issue of the Odisha Gazette for general information.

By order of the Governor

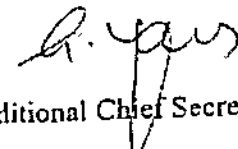
Additional Chief Secretary

Memo No. 1284 / HUD; Dated. 12-01-2024

Copy forwarded to the Director, Printing, Stationeries & Publication, Odisha, Madhupatna, Cuttack, PIN-753010 (Soft copy by e-mail to deputydirectorpp@rediffmail.com) with a request to publish this Notification in the extraordinary issue of the Odisha Gazette and supply 50(fifty) spare copies to this Department.

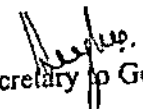
Additional Secretary to Government &
Additional Mission Director, SBM (Urban)
Date: 12-01-2024

Memo No. 1235 / HUD.

Copy forwarded to the Commissioners of all Municipal Corporations/ Executive Officers of all Municipalities and N.A.Cs for information and necessary action.

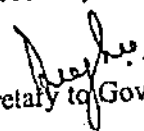
Additional Secretary to Government &
Additional Mission Director, SBM (Urban)

Memo No. 1236 / HUD.

Copy forwarded to the CEO, WATCO / EIC, OWSSB/ EIC, PHEO for information and necessary action.

Additional Secretary to Government &
Additional Mission Director, SBM (Urban)

//True copy//

Memo No. 1,34 HUD

Date: 12-01-2024

Copy forwarded to all the Departments of Government/ all Collectors/ all Project Directors, District Urban Development Agencies for information and necessary action.

[Signature]
Additional Secretary to Government &
Additional Mission Director, SBM (Urban)

1 True copy
✓



Annexure - IV - S
Municipal Administration
and Water Supply (ME-II)
Department, Secretariat,
Chennai-600 009.

Letter No.11088/ME-2/2023 -4, dated:24.01.2024

From

Dr. D. Karthikeyan, I.A.S.,
Principal Secretary to Government.

To

The Secretary,
Government of India,
Ministry of Social Justice and Empowerment,
Department of Social Justice and Empowerment,
New Delhi 110 003.(w.e)

The Joint Registrar(Law),
NHRC, New Delhi.(w.e)

The Secretary, NCSKC,
New Delhi.(w.e)

Sir,

Sub: Supreme Court of India - W.P.(C)No.324/2020 filed by Dr.Balram Singh Vs. Union of India & others - Orders passed by the Hon'ble Supreme Court of India, dated 20.10.2023 - Action Taken/Compliance Report - sent - Regarding.

- Ref:**
1. Order of the Supreme Court of India dated 20.10.2023 passed in W.P.(Civil)No.324 of 2020.
 2. Your File No.12012/01/2023 (PLAN), Ministry of Social Justice and Empowerment, Department of Social Justice, and Empowerment, Government of India, dated 22.12.2023.
 3. G.O.(MS).No.5 Municipal Administration and Water Supply(ME-II) Department dated 23.01.2024.

I am to invite your attention to the references first and second cited and to enclose a copy of the reference 3rd cited.

True copy//

2. I am sending herewith the Action Taken Report in the prescribed format on the directions of Honourable Supreme Court of India, order dated 20.10.2023 filed by Dr.Balram Singh in W.P.(C) No.324 of 2020 as far as Government of Tamil Nadu is concerned.

Yours faithfully,

24/01/2024

for Principal Secretary to Government.

Copy to:-

The Director of Municipal Administration,
Chennai-600 028. (w.e)

The Managing Director,
Chennai Metropolitan Water Supply and Sewerage Board,
Chennai-600 002. (w.e)

//True copy//

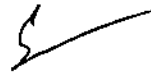

Format for seeking information from State Government / UTs

Name of the State – Tamil Nadu

Actionable Points of Judgment of Hon'ble Supreme Court of India on 20.10.2023 in Writ Petition
(Civil) No.324/2020 filed by Dr. Balram Singh Vs Union of India & Ors.

Sl. No.	Directions of Hon'ble Supreme Court	Action By	Action Taken
1.	The Union should take appropriate measures and frame policies, and issue directions, to all statutory bodies, including corporations, railways, cantonments, as well as agencies under its control, to ensure that manual sewer cleaning is completely eradicated in a phased manner, and also issue such guidelines and directions as are essential, that any sewer cleaning work outsourced, or required to be discharged, by or through contractors or agencies, do not require individuals to enter sewers, for any purpose whatsoever;	Union	<p>It is submitted that the State of Tamilnadu has taken appropriate measures for safe cleaning of septic tanks by machineries to avoid human entry and for this purpose necessary Standard Operating procedures (SoP) have been prepared separately for District Collectors/concerned authorized official, event of post accident, service seeker and desludging operators and this will also be notified in the Gazette shortly.</p> <p>Further, all the septic tank cleaning operations are carried out through mechanized operations for which the following machineries are put into use by the Chennai Metropolitan Water Supply and Sewerage Board in respect</p>

			<p>of Chennai and in other Urban Local Bodies by Director of Municipal Administration and Director of Town Panchayat.</p> <table border="0"> <tr> <td>i. Jet Rodding Machines</td> <td>244</td> </tr> <tr> <td>ii. Desilting Machines</td> <td>376</td> </tr> <tr> <td>iii. Jetting cum suction Machines</td> <td>76</td> </tr> <tr> <td>iv. Super Sucker machines and grab bucket machines</td> <td>60</td> </tr> <tr> <td>v. Robotic sewer cleaning machines</td> <td>14</td> </tr> <tr> <td style="text-align: right;">Total</td> <td>770</td> </tr> </table>	i. Jet Rodding Machines	244	ii. Desilting Machines	376	iii. Jetting cum suction Machines	76	iv. Super Sucker machines and grab bucket machines	60	v. Robotic sewer cleaning machines	14	Total	770
i. Jet Rodding Machines	244														
ii. Desilting Machines	376														
iii. Jetting cum suction Machines	76														
iv. Super Sucker machines and grab bucket machines	60														
v. Robotic sewer cleaning machines	14														
Total	770														
2.	All States and Union Territories are likewise, directed to ensure that all departments, agencies, corporations and other agencies (by whatever name called) ensure that guidelines and directions framed by the Union are embodied in their own guidelines and directions; the states are specifically directed to ensure that such directions are applicable to all municipalities, and local bodies functioning within their territories;	All States and Union Territories	It is submitted that as per the directions of the Hon'ble Supreme Court of India, Guidelines and directions framed by the Union will be incorporated in the own guidelines of the State of Tamil Nadu and it will be ensured that those are applicable to all Municipalities and local bodies												
3.	The Union, State and Union Territories are directed to ensure that full rehabilitation (including employment to the next of kin, education to the wards, and skill training)	Union, State and Union Territories	It is submitted that the Hon'ble Chief Minister of Tamilnadu announced the scheme of "Sanitation Workers Development Scheme" for the safety, security and welfare of sanitation workers engaged in												

17
 317
 317



ABSTRACT

The Prohibition of Employment as Manual Scavengers and their Rehabilitation Act, 2013 (Central Act 25 of 2013) - Orders of the Hon'ble Supreme Court of India in WP (Civil) No.324/2020 - Enhancement of compensation amount to the legal heirs of the victims of sewerage / septic tank works in case of death from Rs.15 lakh to Rs.30 lakh - Orders - Issued.

MUNICIPAL ADMINISTRATION & WATER SUPPLY (ME.II) DEPARTMENT

G.O.(Ms)No.5

Dated: 23.01.2024

திருவள்ளூர் ஆண்டு 2055

சோபகிருது, தை - 09

Read:

1. The Prohibition of Employment as Manual Scavengers and their Rehabilitation Act, 2013 (Central Act 25 of 2013).
2. Orders of the Supreme Court of India in W.P.(Civil)No.583 of 2003 filed by Safai Karamcharis Andolan and others Vs Union of India and others, dated 27.03.2014.
3. Interim orders of the Hon'ble first bench of Madras High Court, in its order dated 10.11.2021, in a batch case comprising of W.P.Nos.17380/2017,31345/2014 and W.P(MD)No.24243 of 2017 filed by Safai Karamchari Andolan, Change India and others, Dated 10.11.2021.
4. G.O.(Ms).No.83, Municipal Administration and Water Supply (MA-2) Department, dated 07.06.2022.
5. Order of the Supreme Court of India in WP(Civil). No.324/2020 dated 20.10.2023.
6. From the Director of Municipal Administration letter Roc.No.17380/ 2017/H1, dated 08.11.2023.

ORDER:

The Government is very cencious of the provisions of the 'Prohibition of Employment as Manual Scavengers and their Rehabilitation Act 2013' and is committed for implementing the same in letter and spirit.

2. The Hon'ble Supreme Court of India In W.P.(Civil)No.583 of 2003 filed by Safal Karamcharis Andolan and others Vs Union of India

True copy!!

318

and others, in its order dated 27.03.2014, inter-alia had issued the following directions:

"Identify the families of all persons who have died in sewerage work (manholes, septic tanks) since 1993 and award compensation of Rs. 10 lakhs for each such death to the family members depending on them."

3. As per the above directions of the Hon'ble Supreme Court, in respect of awarding the above said compensation, the following procedures are followed:-

- i. If the victim of a sewer/septic tank work is a person engaged by the Urban Local Bodies, a compensation of Rs. 10 lakh is being paid to the legal heirs of the deceased by the Urban Local Bodies.
- ii. If the victim of a sewer/septic tank work is a person engaged by a private person or contractor, the compensation amount shall be settled by the concerned employer, to the legal heirs of the deceased.
- iii. If the concerned private employer does not have the capacity to pay the entire compensation amount, the balance amount shall be settled by the concerned local bodies / by the Principal employer from their own fund, to the legal heirs of the deceased.
- iv. If the victim of a sewer/septic tank work is a person employed by the local bodies / Principal employer if any, the concerned local bodies / Principal employer shall pay the compensation amount from their own sources to the legal heirs of the deceased.

4. In the Government Order fourth read above, Government issued orders for enhancement of compensation amount to the legal heirs of the victims of sewerage / septic tank works in case of death from Rs.10 lakh to Rs.15 lakh, and for subsequent enhancement at the rate of Rs.1.5 lakh once in every three years duly following the procedures mentioned at para 3 above as per the directions of the Hon'ble High Court of Madras in the reference third read above.

5. In the reference fifth read above, the Supreme Court of India in its order dated 20.10.2023 in W.P(Civil)No.324 of 2020 among others has delivered the following directions:-

xxx xxx

- 96 (4) The Court hereby directs the Union and States to ensure that the compensation for sewer death is increased (given that the previous amount fixed i.e., Rs.10 lakh) was made applicable from 1993. The current equivalent of that amount is Rs.30 lakh. This shall be the amount to

be paid, by the concerned agency, i.e., the Union, the Union Territory or the State as the case may be. In other words, compensation for sewer deaths shall be Rs.30 lakh. In the event, departments of any victim have not been paid such amount, the above amount shall be payable to them. Furthermore, this shall be the amount to be hereafter paid, as compensation.

96(5) Likewise, in the case of sewer victims suffering disabilities, depending upon the severity of disabilities, compensation shall be disbursed. However, the minimum compensation shall not be less than Rs.10 lakh. If the disability is permanent and renders the victim economically helpless, the compensation shall not be less than Rs.20 lakh.

96(14) A portal and a dashboard, containing all relevant information, including the information relating to sewer deaths, and victims, and the status of compensation disbursement, as well as rehabilitation measures taken, and existing and available rehabilitation policies shall be developed and launched at an early date.

6. In the letter sixth read above, the Director of Municipal Administration has sent a proposal to enhance the compensation to the legal heirs of the victims of sewer/septic tank workers in case of death from Rs.15 lakh to Rs.30 lakh and to fix the compensation of Rs.20 Lakh for the cases of permanent disablements arising from sewer/septic tank operations and a compensation of Rs.10 Lakh for other forms of disablement.

7. The Government after careful examination of the proposal of the Director of Municipal Administration and in compliance of the Hon'ble Supreme Court's directions have decided to accept it and accordingly hereby orders to enhance the compensation amount in respect of sewer/septic tank workers' death from Rs.15 lakh to Rs.30 lakh and in the case of sewer/septic tank victims suffering disabilities, depending upon the severity of disabilities, fixes the compensation however the minimum compensation shall not be less than Rs.10 lakh and if the disability is permanent and renders the victim economically helpless, the compensation shall not be less than Rs.20 lakh shall be awarded based on the procedures mentioned below:-

- (a) If the victim of a sewer/septic tank work is a person engaged by the Urban Local Bodies, then the compensation amount shall be paid by the Urban Local Bodies, to the legal heirs of the victim/deceased.

//True copy//

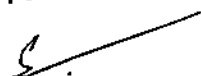

- (b) If the victim of a sewer/septic tank work is a person engaged by a private person/association/contractor/employer, then the compensation amount shall be paid by the concerned person/association/contractor/employer, to the legal heirs of the victim/deceased.
- (c) If the concerned private person/association/contractor/ employer is not able to settle the full compensation amount immediately, the balance unsettled amount which the private person/association/contractor/employer could not settle immediately shall be paid by the concerned local bodies / Principal Employer from their own fund, to the legal heirs of the victim/ deceased and the amount shall be recovered from the private person/ association/contractor/employer later and credited to the local bodies fund.
- (d) The concerned District Collectorate shall be responsible for recovering the compensation amount paid by the Local bodies /Principal Employer from the private person/association/ contractor/ employer under the Tamil Nadu Revenue Recovery Act.

8. The Government also directs the Director of Municipal Administration to develop and launch a portal and dashboard containing all relevant information, including the information relating to sewer / septic tank deaths, victims, the status of compensation disbursement and the rehabilitation details.

9. This order issues with the concurrence of the Finance Department vide file No.11088/Finance (Infra-III)/23, dated 10.01.2024.

(BY ORDER OF THE GOVERNOR)

**D. KARTHIKEYAN
PRINCIPAL SECRETARY TO GOVERNMENT.**

To

The Additional Chief Secretary/Commissioner,
Greater Chennai Corporation, Chennai-600 003.

The Managing Director,
Chennai Metropolitan Water Supply and Sewerage Board,
Chennai-600 002.

The Director of Town Panchayats, Chennai-600 028.

The Director of Municipal Administration, Chennai- 600 028.

The Managing Director,
Tamil Nadu Water Supply and Drainage Board, Chennai-600 005.

The Principal Secretary to Government,

Rural Development & Panchayat Raj Department, Chennai-600 009.

The Secretary to Government,

321

//True copy//
✓

Social Welfare and Women Empowerment Department, Chennai-9.
 The Secretary to Government,
 Adi Dravidar & Tribal Welfare Department, Chennai-600 009.
 The Director of Rural Development and Panchayat Raj,
 Panagal Building, Chennai-600 015.
 The Director, Adi Dravidar Welfare, Chennai-600 005.
 The Director,
 Tamil Nadu Adi Dravidar Housing and Development Corporation
 Limited, Chennai-600 018.
 The Director, Tribal Welfare, Chennai-600 005.
 The Member-Secretary,
 Tamil Nadu State Commission for the Scheduled Castes and
 Scheduled Tribes, Chennai-600 006.
 All District Collectors.
 All Regional Directors of Municipal Administration / Additional Directors
 of Town Panchayats of Urban Local Bodies.
 (Through the Director of Municipal Administration/
 Director of Town Panchayats).
 All Commissioners/Executive Officers of Urban Local Bodies.
 (Through the Director of Municipal Administration/
 Director of Town Panchayats).
 The Government Pleader, High Court of Madras, Chennai- 600 104.
Copy to:
 The Secretary, National Commission for Social Karamcharis,
 'B' Wing, 4th Floor, Lok Nayak Bhawan, Khan Market,
 New Delhi- 110 003.
 The Chairman, National Commission for Human Rights, Block-C, G.P.O.
 Complex, INA, New Delhi - 110 023.
 The Secretary, National Commission for Schedule Castes (Tamil Nadu),
 2nd Floor, Block-5, Shastri Bhawan, Chennai-600006.
 The Office of the Hon'ble Chief Minister, Chennai-600 009.
 The Office of the Hon'ble Minister for Municipal Administration,
 Chennai-600 009.
 The Office of the Hon'ble Minister for Finance and Human Resource
 Management, Chennai-600 009.
 The Office of the Hon'ble Minister for Municipal Administration,
 Chennai-600 009.
 The Office of the Hon'ble Minister for Law, Chennai-600 009.
 The Principal Private Secretary to Chief Secretary to Government,
 Chennai-600 009.
 The Senior Principal Private Secretary to the Principal Secretary to
 Government, Finance Department, Chennai-600 009.
 The Principal Private Secretary to Principal Secretary to Government,
 Municipal Administration and Water Supply Department,
 Chennai-600 009.
 The Senior Private Secretary to the Secretary to Government,
 Law Department, Chennai - 600 009.
 The Law (MAWS-Scrutiny) Department, Chennai-600 009.

//True copy//

The Finance (Infra-III) Department, Chennai-600 009.
The Municipal Administration and Water Supply (MA-III/ME.III/MW/
OP.II) Department, Secretariat, Chennai - 600 009.
SF/SC.

// FORWARDED BY ORDER //

D. V. V. V.
23.01.2024
SECTION OFFICER

//True copy//

✓

Annexure-IV-T

0194-2506067/2506279
0191-2579126/2542759

email: socialwelfare.admt@gmail.com



Union Territory of Jammu and Kashmir
Social Welfare Department
Civil Secretariat, J&K.

Shri S.K. Srivastwa,
Deputy Secretary to the Government of India,
Department of Social Justice and Empowerment,
Ministry of Social Justice and Empowerment,
New Delhi.

No: SWD-LIT/57/2023-02

Dated: 19.01.2024

Subject: - Civil Writ Petition (PI.) No. 324 of 2020 In the matter of Dr. Balaram Singh vs Union of India and Others pending Before Supreme Court of India-regarding.

Sir,

I am directed to refer your letter No. U-12012/01/2023 (Plan) dated 02.01.2024 wherein the department was directed to furnish the Action Taken Report (ATR) in compliance of observations of the order dated 20.10.2023 of Hon'ble Supreme Court regarding the subject cited above. In this regard, I am directed to enclose the point wise reply of the observations as Annexure "A" to this letter for kind of information.

Yours faithfully,

(Sanjay Pandita)

Under Secretary to the Government,
Social Welfare Department

//True copy//

324

6	Set up scholarships to ensure that the dependents of sewer victims (who have died, or might have suffered disabilities) are given meaningful education [para96(10)];	The Pre-matric & Post-matric scholarships scheme for the children of those whose parents or engaged in unclean occupation is already being implemented by the Government of J&K. However, no sewer deaths have been reported in J&K
7	Ensure establishment of State Commission for Safai Karmacharis and all Committees mentioned in MS Act, 2013 and MS Rules 2013 including State Monitoring Committee, State Level Survey Committee, District Vigilance Committee and District Level Survey Committee by 30.11.2023 [para 96 (12)].	Vide S.O.98 dated.23 rd February, 2023, the Government of Jammu & Kashmir has designated the Commissioner, Municipal Corporation Jammu and Commissioner, Municipal Corporation Srinagar as the authorities within Division Jammu and Kashmir. The process of constitution of various UT, District and Sub Division Level Committees has already been initiated and the proposal is under consideration in General Administration Department, J&K.

//True copy//

Annexure "A"

S.No	Observations of Hon'ble Supreme Court	Action Taken Report (ATR)
1	Manual Scavenging Act, 2013; Manual Scavenging Rules, 2013 and guidelines framed by the Union are embodied in States/UTs & Kashmir by virtue of implementation of J&K Re-organization Act, 2019, the guidelines applicable to all municipalities and local bodies [para 96 (2)];	Since the Prohibition of Employment as Manual Scavengers and Rules, 2013 have been extended in the UT Jammu & Kashmir by virtue of implementation of J&K Re-organization Act, 2019, the guidelines framed by the Union are being implemented and followed in letter and spirit across the UT of J&K.
2	Full rehabilitation (including employment to the next of kin, education to the wards, and skill training) of sewage workers, and those who die [para 96 (3)];	The practice of Manual scavenging is not prevalent in UT of J&K. No case of death of Manual Scavengers or who died while doing the sewage work have ever been reported till date in any of the Districts of J&K.
3	Payment of compensation with increased amount i.e., {30 lakhs for sewer deaths. In the event, dependents of any victim have not been paid such amount, the above amount shall be payable to them, here after as compensation [para 96 (4)];	No such case has been reported till date.
4	Payment of compensation of Rs. 20 lakhs, in the case of sewer victims suffering disabilities, depending upon the severity of disabilities. Minimum compensation shall not be less than {10 lakhs [para 96 (5)];	No such case has been reported till date.
5	Devise suitable mechanism to ensure accountability, especially wherever sewer deaths occur in the course of contractual or outsourced "work [para 96 (6)];	No such case has been reported till date.

//True copy//

S



संचालनालय, नगरीय प्रशासन एवं विकास, म.प्र., भोपाल
Directorate, Urban Administration & Development, M.P., Bhopal

Annexure-IV-U

Palika Bhawan, Near 6 No. Bus Stop
Shivaji Nagar, Bhopal - 462016
Tel. 0755-2558796, 2554083
Email:- Hlmanshu.singh@mpurban.gov.in
Website: www.mnurban.gov.in

S. No.: SBM/2024/1828

Bhopal, Date: 25/01/2024

To,

Shri. S.K. Srivastwa
Deputy Secretary
Department of Social Justice and Empowerment
Ministry of Social Justice and Empowerment
Government of India
New Delhi

Subject: Civil Writ Petition (PIL) No. 324 of 2020 in the matter of Dr. Balram Singh VS Union of India and others pending before Supreme Court of India - regarding.

Respected Sir,

This has reference to Letter No. U-12021/1/2023-PLAN dated 14.11.2023 received from Deputy Secretary, Ministry of Social Justice and Empowerment, Government of India, New Delhi regarding Judgement dated 20.10.2023 of Hon'ble Supreme Court in Writ Petition (Civil) No. 324 of 2020 filed by Dr. Balram Singh VS Union of India and others and the requirement of action taken by state on the observations of the Hon'ble Supreme Court.

Please find attached with this letter the action taken report with required annexures.

Encl. - As above

(Shivam Verma)

Mission Director,
Swachh Bharat Mission (U)
Directorate of Urban Administration & Development,
Government of Madhya Pradesh

D. No.: SBM/2024/1829

Bhopal, Date: 29/01/2024

Copy to:-

1. Chief Secretary, Government of Madhya Pradesh.
2. Principal Secretary, GoMP, Urban Development and Housing Department.
3. Commissioner, Urban Administration and Development, MP.

Mission Director,

Swachh Bharat Mission (U)
Directorate of Urban Administration & Development,
Government of Madhya Pradesh

//True copy//

327

**Action taken by Madhya Pradesh state on the directions of
Hon'ble Supreme Court's order dated 20.10.2023**

- A. MS ACT, 2013; MS Rules 2013 and guidelines framed by the union are embodied in states/ UTs guidelines and directions are applicable to all municipalities and local bodies [para 96(2)]; (Annexure 1)
1. State has notified vid Gazette Notification No. F-12-32-2013-4-XXV, dated 05-02-2015, in exercise to the powers conferred by sub-section (1) of section 36 of the Prohibition of Employment as Manual Scavengers and their Rehabilitation Act, 2013 (No. 25 of 2013), the state government, makes rule.
 2. State has notified vid Gazette Notification No. F-12-32-2013-4-XXV-4, dated 2-09-2014, in exercise of the powers conferred by sub-section (1) section 21 of the Prohibition of Employment as Manual Scavengers and their Rehabilitation Act, 2013 (No. 25 of 2013), the state government, hereby, confer the powers of a Judicial Magistrate of the first class for the trial of offences under the said act to the sub-divisional magistrate and he shall be deemed for the purpose of the code of criminal procedure, 1973 (No. 1 of 1974) to be a Judicial Magistrate of first class.
 3. State has notified vid Gazette Notification No. F-12-32-2013-4-XXV-3, dated 2-09-2014, appoints all health officers of Municipal Corporations, Nagar Palika, Nagar Panchayat as inspectors for the purpose of this act.
 4. State has notified vid Gazette Notification No. F-12-32-2013-4-XXV-2, dated 2-09-2014 for conferment of powers and impose such duties on local authority and district magistrate to ensure provisions of the act.
 5. State has notified vid Gazette Notification No. F-12-32-2013-4-XXV-4, dated 15-09-2014 to designate a Madhya Pradesh State Scheduled Caste Commission as an appropriate authority, within state, to perform mutatis mutandis, the functions specified in sub-section (1) of 31.
 6. State has notified vid Gazette Notification No. F-12-32-2013-XXV-1, dated 2-09-2014, in exercise of the powers conferred by section 7 of the PEMSRA- Act 2013, prohibits the engagement or employment of the persons either directly or indirectly of hazardous cleaning of sewers and septic tanks.
 7. State has notified vid Gazette Notification No. F-12-32-2013-4-XXV-4, dated 29-09-2014, in exercise of the powers conferred by section 24 (1) of the PEMSRA- Act 2013, for constitution of Sub-divisional Vigilance Committee.

119900
True COPY

8. State has notified vid Gazette Notification No. F-12-32-2013-XXV-4, dated 29-09-2014, in exercise of the powers conferred by section 26 of the PEMSRA- Act 2013, for constitution of State Monitoring Committee.
 9. State has notified vid Gazette Notification No. F-12-32-2013-XXV-4, dated 29-09-2014, in exercise of the powers conferred by section 11 (2) and 14 of the PEMSRA- Act 2013, constitute State Survey Committee for monitoring of survey for manual scavengers.
 10. State has notified vid Gazette Notification No. F-12-32-2013-XXV-5, dated 2-09-2014, in exercise of the powers conferred by sub-section (2) of section 4 of the PEMSRA- Act 2013, empowers all Municipalities and all Municipal Corporations to construct adequate number of sanitary community latrines, by 06-12-2015 to eliminate the practice of open defecation in their jurisdictions
 11. State has setup Responsible Sanitation Authority (RSA) 52 district HQ ULBs, chaired by the respective District Collector. The RSA under the administrative chairmanship of the district collector functions, for all the ULBs covered under the designated district in the State to ensure that:
 - i. No person is engaged or employed as Manual Scavenger.
 - ii. No one constructs, maintains, uses insanitary latrines.
 - iii. Identified MS are rehabilitated.
 - iv. Persons contravening the provisions of Sections 5,6 or 7 are investigated and prosecuted under the provisions of MS Act.
 12. To address the demand towards manual intervention, the State has set up Emergency Response Sanitation Unit (ERSU) across 52 district HQ ULBs, chaired by respective Commissioner/ CMO and each ESRU serves to demands from respective ULBs within the district jurisdiction: (Annexure 4)
 - i. The ESRU is responsible to meet sanitation emergency requests within their district's jurisdiction which consists of especially trained Sewer Entry Professionals (SEPs).
 - ii. The SEPs have been provided with 9 safety gears which includes Safety Tripod Set, Nylon Rope ladder, Blower with Air Compressor, Gas Monitor (4 Gases), Full body Wader Suit, Gas Mask, Breathing Apparatus, Safety body Harness, Air Line Breathing Apparatus. This is to ensure that no body part of the sanitary worker remains exposed while undertaking hazardous cleaning.
- B. Full rehabilitation (including employment to the next kin, education to the wards, and skill training) of sewage workers, and those who die (para 96(3));**
1. In accordance with "The Prohibition of Employment as Manual Scavengers and their Rehabilitation Act, 2013" (herein after referred as the Act of 2013), the State had Identified 506 Manual Scavengers. Based on the available provisions, these identified scavengers were provided

//True copy//
329

with skill trainings for self-employment along with Rs. 40,000/- each for the sustainability of their immediate livelihood.

2. As per the guidelines issued under Safaimitra Suraksha Challenge of Swachh Survekshan under Swachh Bharat Mission:
 - a. ULBs and Cities have ensured as well as registered erstwhile manual scavengers enumerated by MoSJE, also provided with livelihood opportunities – e.g. employed as sewermen/ beidars, engaged as CT/PT caretakers or supported entrepreneurship model through access to subsidized loan (Loan Mea) and assured engagement of their equipment.
 - b. All ULBs of the state have provisioned their sanitary workers with at least three eligible government welfare schemes such as Ayushman Bharat, Life/Accident Insurance, Education, providing Ration cards for subsidized food grain, etc.
 3. Sanitation workers and ULBs are provided with loan under Swachhta Udyami Yojna (SUJ) scheme funded by National Safai Karamcharis Finance and Development Corporation (NSKFDC) under Ministry of Social Justice and Empowerment, to procure any of the above stated Core or Special Equipment and where the said loanee is assured of engagement of the equipment in management of sanitation services of the ULB.
 - a. Since 2021, 54 sanitation workers are created entrepreneurs provided with loan and total fund of 5.7 crore has been disbursed.
 - b. Since 2019, 15 ULBs are provided with the loan for 131 total equipment/ vehicles and total fund of 26.0136 crore has been disbursed.
 4. Under Swachh Bharat Mission, the Urban Local Bodies are mandated to formalize informal workers, for the same:
 - a. Urban local bodies have issued a notification to all informal workers to register themselves with the ULB to integrate them into a formal system.
 - b. To ensure only trained workers are engaged in carrying hazardous cleaning work, each personnel must undergo a Training program and attain certificate before being allowed to engage in carrying out hazardous cleaning works.
 5. As per the advisory by Ministry of Housing and Urban Affairs on Emergency Response Sanitation Unit (ERSU) published in 2019. With the reference to the same, the state has published Standard Operating Procedure (SOP) on the cleaning of sewer and septic tank in March 2022. Urban Local Bodies are mandated to follow the SOP directed by the state. (Annexure 2)
- C. Payment of compensation with increased amount i.e. 30 lakhs for sewer deaths. In the event, dependents of any victim have not been paid such amount, the above amount shall be payable to them, hereafter as compensation [para 96(4)];

Until June 2023, 20 manual scavengers' deaths have been reported and compensation of INR 10 Lakhs has been released to dependent family as per order given by Hon'ble Supreme Court. Letter released by state for the compensation on account of death due to manual scavenging is attached (Annexure 3).

List of deaths of Manual Scavengers/ sanitation workers involved in Hazardous cleaning:

//True copy//

S.No.	Date & Time of Incident	Place of the Incident along with PIN code	Police Station/ Tehsil/ Taluka/ Municipal Council/ Municipal Corporation	District & State of the Incident	Name, Father/ Mother's Name of the deceased person	Sex, Age	Address of the deceased person	Details, if belonging to the Scheduled Caste/ Scheduled Tribes	Details of the monetary and other assistance provided/ to be provided to the next of kin of the deceased
1	11/10/2003	-	Municipal Corporation Gwalior	Gwalior, MP	Ganesh S/o Dasarath	M, -	-	-	Compensation of 10 Lakhs provided on 16/11/2018
2	16/06/2004	Gola ka mandir, gwalior-474004	Municipal Corporation Gwalior	Gwalior, MP	Dharmendra (Kallu) S/o Late Lalram	M, -	Near P.H.E karyaalay, khedapati, lashkar, gwalior	-	Compensation of 6 Lakhs (01/12/2020), 2.80 Lakhs (09/02/2021), 1.20 Lakhs (03.05.2021)
3	8/6/2014	-	Municipal Parishad Jhundpura	Morena, MP	Vinod Balmik 6/o Ramesh Balmik	M, -	-	-	Compensation of 10 Lakhs provided on 16/6/2015
4	8/6/2014	-	Municipal Parishad Jhundpura	Morena, MP	Manoj Balmik S/o Ramprakash Balmik	M, -	-	-	Compensation of 10 Lakhs provided on 16/6/2015
5	22/9/2014	-	Municipal Council Shivpuri	Shivpuri, MP	Deepu Balmik S/o Dataram Balmik	M, -	-	-	Compensation of 10 Lakhs provided on 16/6/2015
6	22/9/2014	-	Municipal Council Shivpuri	Shivpuri, MP	Rajendra Balmik S/o Lal Balmik	M, -	-	-	Compensation of 10 Lakhs provided on 16/6/2015
7	28/5/2016	Meat Market Shivpuri-473551	Municipal Council Shivpuri	Shivpuri, MP	Kalla Balmik S/o Tej Singh Balmik	M, -	-	-	Compensation of 10 Lakhs provided on 6/1/2017
8	28/5/2016	Meat Market Shivpuri-473551	Municipal Council Shivpuri	Shivpuri, MP	Raju urf Halke Balmik S/o Itwari Balmik	M, -	-	-	Compensation of 10 Lakhs provided on 6/1/2017

331

9	1/4/2019	Badh ganga main road- 452001	Municipal Corporation Indore	Indora, MP	Safikool Islam	M, 34	Village south achardna, P.S. Ialgola, dist. Murshidavad, West Bengal	Compensation of 10 Lakhs provided on 07/10/2019
10	27/09/2008	Industrial area, A.B. road, Dewas - 455001	Municipal Corporation Dewas	Dewas, MP	Mohanlal Ved S/o Munshilal Ved	M, 42	Dhancha bhawan, Dewas	Compensation of 10 Lakhs provided on 22/12/2021
11	27/09/2008	Industrial area, A.B. road, Dewas - 455001	Municipal Corporation Dewas	Dewas, MP	Shriram Sarwan S/o Nazirul sarwan	M, 32	Makan No.128, Dhacha bhavan, jayprakash nagar Dewas, 455001	Compensation of 10 Lakhs provided on 22/12/2021
12	24/09/2021	Kachani, singrauli- 486889	Municipal Corporation Singrauli	Singrauli, MP	Kanhiyalal Yadav S/o Chhotelal Yadav	M, 26	Chachar, Jarha, Singrauli, MP 486886	Monetary Compensation of 10 Lakhs provided on 03/02/2022
13	24/09/2021	Kachani, singrauli- 486889	Municipal Corporation Singrauli	Singrauli, MP	Indrabhan Singh S/o Davraj Singh	M,	Rajdaha, Sakalya, chitrangl, singrauli, MP 486882	Compensation of 10 Lakhs provided on 03/02/2022
14	24/09/2021	Kachani, singrauli- 486889	Municipal Corporation Singrauli	Singrauli, MP	Narendra Kumar Rajak S/o Ragunath Rajak	M, 36	Chingl Tola, Pondi Naugai, singrauli, MP 486886	Compensation of 10 Lakhs provided on 03/02/2022
15	13/12/2021	Laukhedi, bhopal- 462030	Municipal Corporation Bhopal	Bhopal, MP	Deepak Kumar S/o Ramvraksh Singh	M, 29	Village Sirsiya, Kushinagar, Sahabazpur, Uttar- Pradesh- 274206	Compensation of 10 Lakhs provided on 11/01/2022
16	13/12/2021	Laukhedi, bhopal- 462030	Municipal Corporation Bhopal	Bhopal, MP	Bharat Singh S/o Saitan Singh	M, 16	Plpalipada, Jhabua, MP 457779	Compensation of 10 Lakhs provided on 24/12/2021

PTT

17	10/2/2006	Lashkar-474001	Municipal Corporation Gwalior	Gwalior, MP	Deepu S/o Shri.Gainda Chauhan	M,-	ChandraVadn ka naka, Lashkar, Gwalior	Compensation of 10 Lakhs provided on 12/05/2023
18	10/2/2006	Lashkar-474001	Municipal Corporation Gwalior	Gwalior, MP	Veeru S/o Shri.Gainda Chauhan	M,-	ChandraVadn ka naka, Lashkar, Gwalior	Compensation of 10 Lakhs provided on 12/05/2023
19	15/6/2023	Hazra, Gwalior 474003	Municipal Corporation Gwalior	Gwalior, MP	Vikram Gohel S/o Sitaram Gohel	M, 30	Shinde ki Chhawanl, Lashkar, Gwalior	Compensation of 10 Lakhs provided on 20/6/2023
20	15/6/2023	Hazra, Gwalior 474003	Municipal Corporation Gwalior	Gwalior, MP	Aman Balmiki S/o Ram prasad Balmiki	M, 24	Jagnapura No.1, Latherl, near police station, Gwalior	Compensation of 10 Lakhs provided on 20/6/2023

D. Payment of compensation of Rs. 20 lakhs, in the case of sewer victims suffering disabilities, depending upon the severity of disabilities. Minimum compensation shall not be less than Rs. 10 lakhs [para 96(5)]

Till date only case of manual scavengers' deaths has been reported, no case of sewer victims suffering disabilities has been reported so far.

//True copy//

333

इसे वेबसाईट www.govtpressmp.nic.in
से भी डाउन लोड किया जा सकता है.



मध्यप्रदेश राजपत्र

(असाधारण)

प्राधिकार से प्रकाशित

क्रमांक 54]

भोपाल, गुरुवार, दिनांक 5 फरवरी 2015—माघ 16, शक 1936

अनुसूचित जाति कल्याण विभाग

मंत्रालय, वल्लभ भवन, भोपाल

भोपाल, दिनांक 5 फरवरी 2015

क्र. F-12-32-2013-4-पच्चीस.—हाथ से मैला उठाने वाले कर्मियों के नियोजन का प्रतिषेध और उनका पुनर्वास अधिनियम, 2013 (2013 का 25) की धारा 36 की उपधारा (1) द्वारा प्रदत्त शक्तियों को प्रयोग में लाते हुए, राज्य सरकार, एतद्द्वारा, निम्नलिखित नियम बनाती है, अर्थात् :-

नियम

अध्याय 1

साधारण

संक्षिप्त नाम और प्रारंभ—(1) इन नियमों का संक्षिप्त नाम मध्यप्रदेश हाथ से मैला उठाने वाले कर्मियों के नियोजन का प्रतिषेध और उनका पुनर्वास नियम, 2014 है.

(2) ये "मध्यप्रदेश राजपत्र" में इनके प्रकाशन की तारीख से प्रवृत्त होंगे.

2. परिभाषाएं.—(1) इन नियमों में, जब तक कि संदर्भ से अन्यथा अपेक्षित न हो,—

(क) "अधिनियम" से अभिप्रेत है, हाथ से मैला उठाने वाले कर्मियों के नियोजन का प्रतिषेध और उनका पुनर्वास अधिनियम, 2013 (2013 का 25).

(ख) "सफाई युक्ति" से अभिप्रेत है और उसमें सम्मिलित होंगे किन्तु नियम 5 में निर्दिष्ट उपस्करों तक सीमित न करते हुए चाहे हाथ से या यांत्रिक रूप से प्रचालित हो जिनका उपयोग—

(एक)) सैण्टिक टैंक से मल नाली या मल विगलन की सफाई या परिवहन या प्रवाह को साफ करने या समर्थ बनाने के लिये; और

(दो) ऐसी मल या सामग्री के साथ सीधे संपर्क को बचाने के लिये, किया जा सके.

(ग) (एक) "जिला समिति" से अभिप्रेत है, निम्नलिखित संरचना के साथ नियम 11(2), 11(18) और 11(19) में निर्दिष्ट समिति :-

- | | | | |
|-----|--------------------------------------------------------------------------------------------------------------------------------------------------------------|---|------------|
| (1) | जिला मजिस्ट्रेट | — | अध्यक्ष |
| (2) | अनुसूचित जाति मामलों को व्यवहार करने वाला जिला स्तर का अधिकारी. | — | सदस्य सचिव |
| (3) | जिला सांख्यिकीय अधिकारी | — | सदस्य |
| (4) | नगरीय विकास विभाग का जिला स्तर का अधिकारी. | — | सदस्य |
| (5) | रेल प्राधिकरण का एक प्रतिनिधि | — | सदस्य |
| (6) | हाथ से मैला उठाने वाले कर्मियों और सफाई कर्मचारियों के कल्याण के लिये कार्यरत गैर सरकारी संगठनों के जिला मजिस्ट्रेट द्वारा नामनिर्दिष्ट अधिकतम दो प्रतिनिधि. | — | सदस्य |
| (7) | जिला मजिस्ट्रेट द्वारा नामनिर्दिष्ट अधिकतम दो सामुदायिक प्रतिनिधि जिसमें से एक महिला होगी. | — | सदस्य |

(दो) जिला स्तर सर्वेक्षण समिति के कृत्य.—

- (एक) जिला स्तर पर सर्वेक्षण प्रक्रिया को मानीटर और सर्वेक्षण करना.
- (दो) अभिहित स्थानों पर जागरूकता अभियान के लिये सामग्री वितरित करना.
- (तीन) सर्वेक्षण के बारे में स्थानीय समाचार पत्र आदि के माध्यम से प्रचार की व्यवस्था करना.
- (चार) अपनी अधिकारिता के अधीन अभिहित स्थानों पर अनुदित सर्वेक्षण सामग्री वितरित करना.
- (पांच) जिले के समस्त शहरों, नगरों और ग्रामों के लिये हाथ से मैला उठाने वाले कर्मियों की अंतिम सूची को अनुमोदित करना.
- (छह) जिले में हाथ से मैला उठाने वाले कर्मियों की अंतिम समेकित सूची का प्रकाशन करना.
- (घ) "प्रणक" से अभिप्रेत है हाथ से मैला उठाने वाले कर्मियों के सर्वेक्षण या सत्यापन के प्रयोजन के लिये किसी स्थानीय प्राधिकरण द्वारा नियोजित कोई व्यक्ति;
- (ङ) "निरीक्षक" से अभिप्रेत है अधिनियम की धारा 20 की उपधारा (1) के उपबंधों के अनुसार राज्य सरकार द्वारा "निरीक्षक" के रूप में नियुक्त कोई व्यक्ति;
- (च) "ओवरसियर" से अभिप्रेत इन नियमों के अधीन शक्तियों के प्रयोग या कर्तव्यों के निर्वहन के लिये स्थानीय प्राधिकरण द्वारा नियोजित कोई अधिकारी;
- (छ) "संरक्षात्मक साधनों" से अभिप्रेत है व्यक्तिगत सुरक्षा उपस्कर और सुरक्षा युक्तियां, जो मल नाली और मल विगलन कुंडों की सफाई के संबंध में सफाई कर्मचारियों या सफाई कर्मकारों द्वारा पहनने के लिये या उपयोग के लिये उपलब्ध कराए जाते हैं, जो कार्य की विशिष्ट प्रकृति को करने के लिये आवश्यक होंगे जिसके अंतर्गत नियम 4 में निर्दिष्ट सामग्री को सीमित नहीं किया गया है—

True copy

(एक)

पदाधीन को मानव त्वचा को संपर्क से बचाने के लिये जो किसी रोग का कारण हो सकती है, जिसके साथ सभी रक्तजन उपकरण जिससे रोगों के अंतःसंचयन से रोग का जा सकने जो रोग का कारण हो सकता है, और जिसके अंतर्गत मल नालियों या मल विमान कुंडों के अंदर उपस्थित गैसों को पहचान के लिये कोई संवेदी उपकरण भी है;

(दो)

क्षति को दूर करना जब सफाई कार्य किया जा रहा हो।

(ब)

"सफाई कर्मचारी" या "स्वच्छता कर्मकार" से अभिप्रेत है धोरे कार्य से भिन्न किसी स्वच्छता कार्य के लिये लगा हुआ या नियोजित कोई व्यक्ति;

(ग)

"सुरक्षा पूर्ववर्धनाधिनियाँ" में सम्मिलित है किन्तु नियम 6 में निर्दिष्ट पूर्ववर्धनाधिनियों तक सीमित नहीं है तथा जिसके अन्तर्गत मल नाली और मल विमान कुंडों को सफाई में लगे हुए व्यक्तियों द्वारा रोगों और क्षतियों के संपर्क को दूर करने को तथा व्यक्तियों के जोखिम को कम करने के लिये सभी आवश्यक उपकरण भी हैं जो मल नाली या मल विमान कुंडों के भीतर और जब मल नाली या मल विमान कुंडों में प्रवेश करने के दौरान कोई भौतिक अवस्था (ठोस, द्रव्य या गैस) में मल या कोई अन्य सामग्री के संपर्क में आते हैं;

(घ)

"राज्य स्तर सर्वेक्षण समिति" से अभिप्रेत है निम्नलिखित संरचना के साथ नियम 10(12), 10(13) और 11(2) में निर्दिष्ट समिति :-

(1)

राज्य सरकार द्वारा नामनिर्दिष्ट अतिरिक्त मुख्य सचिव या प्रमुख सचिव

(2)

यदि अतिरिक्त मुख्य सचिव द्वारा समिति की अध्यक्षता की जाती है तो अनुसूचित जाति मामलों के कार्यकर्ताओं को करने वाला प्रमुख सचिव/सचिव, यदि प्रमुख सचिव अनुसूचित जाति कल्याण स्वयं सहायता कर रहा है तो निर्देशक, अनुसूचित जाति कल्याण

(3)

निर्देशक, अर्थशास्त्र और सांख्यिकीय

(4)

सचिव, राष्ट्रीय विकास एवं पर्यावरण विभाग

(5)

प्रदेशिक निर्देशक, जनगणना प्रबलन

(6)

रेल प्राधिकरण का एक प्रतिनिधि

(7)

दोष से मैला उतारने वाले कर्मियों और सफाई कर्मचारियों के कल्याण के लिये कार्यरत गैर सरकारी संगठनों के

(8)

राज्य सरकार द्वारा नामनिर्दिष्ट अधिकतम दो सामुदायिक प्रतिनिधि जिसमें से एक महिला होगी।

(तीन) राज्य स्तर सर्वेक्षण समिति के कर्त्तव्य :-

(एक)

राज्य स्तर पर सर्वेक्षण प्रक्रिया को मानिटर और सर्वेक्षण करना।

(दो)

अभिहित स्थानों पर जाणकारी अधिपान के लिये सामग्री विस्तारित करना।

(तीन)

सर्वेक्षण के बारे में स्थानीय समाचार पत्र आदि के माध्यम से प्रचार की व्यवस्था करना।

(चार)

अपनी अधिकारिता के अर्धीन अभिहित स्थानों पर अनिर्दिष्ट सर्वेक्षण सामग्री विस्तारित करना।

(पांच)

राज्य के समस्त शहरों, नगरों और ग्रामों के लिये दोष से मैला उतारने वाले कर्मियों की अंतिम सूची को अनुसूचित करना।

(छह)

राज्य में दोष से मैला उतारने वाले कर्मियों की अंतिम सूची का प्रकाशन।

(2) उन शब्दों और अभिव्यक्तियों के जो इन नियमों में प्रयुक्त किए गए हैं और परिभाषित नहीं है किन्तु अभिनियम में परिभाषित हैं, वही अर्थ होंगे जो अभिनियम में उन्हें सममुद्रेशित किए गए हैं.

अध्याय दो

मल नाली या मल विगलन कुंडों की सफाई में नियोजित कर्मचारियों के प्रति नियोजक की बाध्यताएं

3. नियोजक की बाध्यताएं—(1) इन नियमों के अधीन किसी व्यक्ति को संरक्षणात्मक साधनों और सुरक्षा युक्तियों के बिना किसी मल नाली की सफाई के लिये अनुज्ञात नहीं किया जाएगा सिवाय :—

- (क) कंक्रीट या फाइबर प्रवर्तित प्लास्टिक (एफ. आर. पी.) या क्षतिग्रस्त मेनहोल डोर जहां यांत्रिक उपकरण प्रचालन में उपयोग नहीं किए जा सकते हैं, को हटाने के लिए;
- (ख) तीन सौ मिलीमीटर व्यास से अधिक आकार की मल नाली की दशा में, विद्यमान मुख्य मल नाली के साथ डाली गई नई मुख्य डाली गई मल नाली के अंतसंयोजन के लिये;
- (ग) चूषण कूपों के तल पर नियत सबमर्सिबल पम्प सेटों को हटाने के लिये;
- (घ) मेन होल के पुनर्निर्माण या मुख्य मल नाली के सुधार के लिये;
- (ङ) ऐसी सफाई अनुज्ञात करने के लिये विनिर्दिष्ट विधिमान्य कारणों को लेखबद्ध करने के पश्चात् स्थानीय प्राधिकरण के मुख्य कार्यकारी अधिकारी की अनुज्ञा प्राप्त करने के पश्चात् किसी परिस्थिति में जब हथ से मलवाही की सफाई नितांत रूप से आवश्यक है;
- (च) उपधारा (1) के खण्ड (ग) और खण्ड (घ) के प्रयोजनों के लिये मल नाली में किसी व्यक्ति के प्रवेश को अनुज्ञात करने से पहले मलवाही पूर्णतया खाली होगी;

4. सुरक्षात्मक नियम तथा सुरक्षा युक्तियों के उपबंध—किसी मल नाली या किसी मल विगलन कुंड की सफाई में नियोजित किसी व्यक्ति को उसके नियोजक द्वारा संरक्षणात्मक साधनों और सुरक्षा उपकरण, निम्नलिखित को सीमित किए बिना, उपलब्ध कराने होंगे :—

- (1) ब्लोअर के लिये वायु संपीड़ित्र
- (2) वायु रेखा श्वसन उपकरण
- (3) हस्त चालित वायु ब्लोअर के सहित वायु रेखा श्वसित्र
- (4) वायु शोधक गैस मास्क/चिन काट्रिज
- (5) कृत्रिम श्वसन/जालिका
- (6) अवरोध चोलावनी फ्रीता
- (7) अवरोधक क्रीम
- (8) अवरोधक शंकू
- (9) ब्लोअर
- (10) श्वसन मास्क
- (11) श्वसन उपकरण
- (12) चोलावनी पट्ट

M. N. S. S. S.

- (13) क्लोरीन मास्क
- (14) आक्स्मिक चिकित्सा आक्सीजन पुनर्जीवक किट
- (15) प्राथमिक चिकित्सा बॉक्स
- (16) फेस मास्क
- (17) गैस मानीटर (4 गैस)
- (18) मार्गनिर्देश नद समूह
- (19) पूर्ण शरीर जलम सूट
- (20) जूतों के साथ संबद्ध मत्स्य जलम सूट
- (21) हाथ के दस्ताने
- (22) सिरो दीप
- (23) हेलमेट
- (24) हेलमेट विध्वंसक
- (25) सीसा एसीटेट पत्र
- (26) जीवनरक्षक गद्दी
- (27) अनुकूलन वायुरेखा प्रदाय ठेला प्रणाली
- (28) सामान्य चेहरा मास्क
- (29) नाथलॉन रस्से की सीढ़ी पांच मीटर
- (30) नाथलॉन सुरक्षा पेटी
- (31) जेबी पुस्तक
- (32) पोर्ट ऑक्सी
- (33) बरसाती
- (34) परावर्तक आवरण
- (35) सुरक्षा पेटी
- (36) शारीरिक सुरक्षा कपड़े
- (37) शारीरिक सुरक्षा सज्जा
- (38) सुरक्षा चश्में
- (39) सुरक्षा गम बूट
- (40) सुरक्षा टोप
- (41) सुरक्षा फुआरा
- (42) सुरक्षा टार्च

//True copy//

(43) सुरक्षा दंडपांड सेट

(44) सर्व लाइट

5. स्थानीय प्राधिकारी-स्थानीय प्राधिकारी यह सुनिश्चित करने कि निम्नलिखित सफाई की युक्तियां मलकूद या मलविगलन कूद की सफाई में लगे व्यक्तियों द्वारा प्रयोग की जाती है किन्तु यह निम्नलिखित तक सीमित नहीं होगी :-

(1) मल नाली स्वच्छता बकेटिंग मशीन

(2) बोटिंग मशीन

(3) बूथ मशीन (गैली एमएमए)

(4) संघटित मशीन (बोटिंग सह बूथ)

(5) गहन बूथ संघटित मशीन (बोटिंग सह बूथ)

(6) हल प्रचालित टॉली आरुह ग्राह बाट्टी

(7) हाइड्रोलिक प्रचालित टॉली आरुह ग्राह बाट्टी

(8) ट्रक आरुह मोटर और विंच प्रचालित ग्राह बाट्टी मशीन

(9) निचल बनावट आरुह मोटर और विंच प्रचालित ग्राह बाट्टी मशीन

(10) गल कूप के लिये रिक्शा आरुह विंच और मोटर प्रचालित डिसेलेंटिंग मशीन

(11) प्रवेश छिद्र के लिये रिक्शा आरुह विंच और सहायक इंजन प्रचालित डिसेलेंटिंग मशीन

(12) एसकाई हाइड्रोलिक विंच प्रचालित ग्राह बाट्टी डिसेलेंटिंग मशीन

(13) हलचालित छड़े, बलवा, फावड़े, गाली साफ करने की मशीनें और हल्यों सहित इत्यादि संकेपस

(14) हल और धुलाई उपकरण

6. संरक्षणात्मक निगर तथा सुरक्षा युक्तियां—(1) इन नियमों के अधीन सभी संरक्षणात्मक निगर और सुरक्षा युक्तियों को प्रत्येक छह मास में जांच की जाएगी और नियोजक द्वारा आवश्यक मरम्मत या प्रतिस्थापन किया जाएगा जो मल नाली या मल विगलन कूद को साफ करने के लिये किसी व्यक्ति को लाना है।

(2) आरामदायक शरीर के कपड़े उस कर्मकार को उपलब्ध कराए जाएंगे जिसे मल नाली या मल विगलन कूद में उनकी सफाई के लिये प्रवेश करना है। नियोजक उन कर्मकारों को पूर्ण शरीर के कपड़े उपलब्ध कराएगा जो 5 फीट से अधिक की गहराई में मल होल में प्रवेश कर रहे हैं और अनुकल्पी रूप से भागतः फिशिंग वाइर काया प्रयोगक उन व्यक्तियों को उपलब्ध कराएगा जो 5 फीट से कम की गहराई में मलहोल में प्रवेश कर रहे हैं।

(3) नियोजक, मल नाली या मलविगलन कूद की सफाई में किसी व्यक्ति के लाने से पूर्व निम्नलिखित सुरक्षा पूर्ववर्धनियां भी सुनिश्चित करेगा, अर्थात् :-

(क) पूरे समय न्यूनतम तीन कर्मचारी रहेंगे जिनमें से एक पर्यवेक्षक होगा;

(ख) परिलुद्ध स्थान के भीतर वातावरण को आक्सीजन की कमी और संमितित विषैली कंबस्टीबल गैसों के लिये परीक्षण किया जाएगा किन्तु निम्नलिखित को संमितित करते हुए परा लाने के परीक्षणों के माध्यम से हाइड्रोजन संतृप्तकृत, कार्बन मोनोक्साइड, मीथेन और गैसीय गैसों के लिये विषालु गैसों तक सीमित नहीं होगी :-

(एक) मलहोल में परा लाने वाले लैंप को जीवंत करना।

True copy

339

- (दो) भीगा सीसा, एसीटेट पेपर का अंतःस्थापन जो परिसंकटमय गैसों की उपस्थिति में रंग को परिवर्तन करता है.
- (तीन) गैस अन्वेषक नकाबों के माध्यम से गैसों का पता लगाना.
- (ग) उपनियम (1) के अधीन स्वच्छता प्रारंभ करने से पूर्व उपनियम (3) के खण्ड (क) में निर्दिष्ट पर्यवेक्षक ने निरीक्षण किया है और अवधारित किया है यदि निकटवर्ती कोई उद्योग मलनाली का उपयोग कर रहा है जिससे किसी परिसंकटमय वातावरण की प्रत्याशा का सामना किया जा सकता है.
- (घ) धातुदंड सीढ़ियों और मेनहोल की पार्श्व दीवारों की दशाएं यह देखने के लिये जांची जाएगी यदि उनके ढहने का कोई खतरा है.
- (ङ) यातायात और पैदल चलने वाले व्यक्तियों के लिये सभी समय बैरीकेड उपलब्ध किए जाते हैं.
- (च) एक पलैगमैन स्थल से कम से कम 50 फिट आगे तैनात होना चाहिए और आने वाले यातायात के लिये कम से कम 500 से दृश्यमान होना चाहिए.
- (छ) मलनाली कर्मचारों की नियमित चिकित्सा जांच जिसमें श्वसन अंग, त्वचा क्षति और अन्य कृतिक रोग की जांच और क्षतियां उनके उपचार के लिये यह सुनिश्चित करने के लिये सम्मिलित होगी कि मलनाली कर्मकार जो ऐसी बीमारियों और क्षतियों से प्रभावित हैं, सफाई के लिये मलनाली में प्रवेश न करें.
- (ज) श्वसन और त्वचा रोगों और अन्य कृतिक रोगों के विरुद्ध नियमित टीकाकरण जिसके लिये इन कर्मियों का मलनाली में हानिकर पदार्थों और गैसों से प्रभावित होने का खतरा बना रहता है.
- (झ) सभी कर्मचारी जो स्थल पर सफाई कार्य के दौरान उपस्थित रहते हैं, ऐसे कार्यों से सहबद्ध क्षति या रोगों से बचने के लिये सफाई कार्य में अंतर्वलित सभी उपस्करों के प्रचालन का प्रशिक्षण दिया जाता है तथा ज्ञान से पर्याप्त रूप से सुपरिचित हों और कार्यस्थान पर आपातस्थिति पैदा होने की दशा में आवश्यक कदम उठाने के लिये समक्ष हो और प्रत्येक दो वर्ष में प्रशिक्षण संचालित किया जाएगा और कर्मचारी उपरोक्त विषय के संबंध में पद्धति और तकनीक में किन्हीं परिवर्तनों से सुपरिचित होंगे.
- (ञ) पर्यवेक्षक निकटतम अस्पतालों और चिकित्सालयों के नाम, पते और टेलीफोन नंबरों को अपने पास और सुविधाजनक स्थिति में रखेंगे.
- (ट) मलनाली या मलविगलन कुंड की सफाई, (एक) केवल दिन के प्रकाश में की जाएगी; और (दो) किसी खण्ड पर नब्बे मिनट से अधिक की अवधि के लिये नहीं होगी दो खण्डों के बीच तीस मिनट का माध्यम देना आज्ञापक होगा;
- (ठ) किन्हीं लाइनकी पहचान करना और उसे बंद करना या पुनः मार्गी करना जिससे या जिनके माध्यम से कार्यक्षेत्र में हानिकर पदार्थ लाए जाते हैं;
- (ड) यह सुनिश्चित करना कि प्रवेश स्थल पर लिखित प्रचालन और बचाव प्रक्रियाएं दर्शित की गई हैं;
- (ढ) यदि प्रवेश शिखर द्वार के माध्यम से किया जाता है, काम में लगने वाली हाउसिंग युक्ति जो किसी व्यक्ति को सीधे प्रास्थिति में निलंबित करती है और यांत्रिक युक्ति पांच फीट की गहराई से अधिक उर्ध्वाधन स्थान से पुनः प्राप्त कर्मिकों को उपलब्ध कराई जाएगी;
- (ण) किसी परिरुद्ध स्थल कार्य के दौरान कम से कम एक व्यक्ति प्राथमिक चिकित्सा और हृदय फुस्फुस पुनरुज्जीवन (कार्डियो पलमनरी रेसूसिटेशन) में प्रशिक्षित होना चाहिए जो तुरंत उपलब्ध हो;
- (त) मेनहोल में आक्सीसजन अंतर्वस्तु सभी स्तरों पर (तल, मध्य और शिखर) में मेनहोल उपाय के परिरुद्ध स्थान में कम से कम 19.5 प्रतिशत होनी चाहिए और यदि आक्सीजन स्तर 19.5 प्रतिशत से कम है और 21 प्रतिशत से अधिक है तो कोई व्यक्ति मेनहोल में प्रवेश नहीं करें;
- (थ) प्रचालन के प्रारंभ से पूर्व मेनहोल को कम से कम एक घंटे पहले खोला जाएगा;

- (द) खोले गए मेनहोल में किसी व्यक्ति, विशेषकर बालकों को जो मलनाली में दुर्घटनावश गिर जाते हैं, उन्हें रोकने के लिये समुचित रूप से बाड़ या रूकावट करनी होगी. वेल्डिड फ़ैब्रिक या वायर नेट से छद्म कवर का उपयोग किया जा सकेगा;
- (ध) सभी कर्मों मलनालीलाइन में प्रवेश करने से पूर्व सुरक्षात्मक साधनों और सुरक्षा युक्तियों का उपयोग करेंगे;
- (न) मेनहोल रंगदंडा या चरणों की संरचनात्मक सुरक्षा की मेनहोल में प्रवेश करने से पूर्व जांच की जानी चाहिए;
- (प) जहां आवश्यक है सुवाह्य एल्यूमिनियम सीढ़ी कार्य अवधि के दौरान उपलब्ध हो और सुवाह्य सीढ़ी को प्रयोग करने के दौरान उसे समुचित रूप से बैठाया या निचल किया गया हो;
- (फ) किनारे के समीप कोई सामग्री या औजार नहीं होने चाहिए जो मेनहोल में गिर सकते हैं और कर्मकार को क्षति पहुंचा सकते हैं;
- (ब) मलनाली की सफाई के दौरान उपयोग किए गए उपस्कर विस्फोटक और अग्निरोधी हों.
- (भ) धूम्रपान, खुली लपटें, मेनहोल के अंदर के साधु-साध खुले मेनहोल के ठीक निकट प्रतिषिद्ध है.
- (म) अचानक या अघोषित वातावरण में परिवर्तन की दशा में कम से कम 10 मिनट वायु प्रदाय के साथ आपात बचाव स्वसन साधित्र पहनना चाहिए.

7. सुरक्षा पूर्वाधानियां.—नियोजक उस समय जब व्यक्ति मलनाली या मल विगलन कुंड की सफाई में लगा है, निम्नलिखित सुरक्षा पूर्वाधानियां को सुनिश्चित करेगा :—

- (एक) अच्छी चालती हलत में बैटरी के साथ सुवाह्य पंखे और एयर ब्लोयर जिसमें मलनाली में व्यक्ति के प्रवेश के दौरान प्राक्कलित अवधि से अधिक अवधि की चालन क्षमता हो, संवातन के लिए मलनाली में लगाए जाएंगे और संवातन खोत मेनहोल के मुख में संस्थित किए जाएंगे.
- (दो) फ्लेश लाइट और द्विपथ रेडियो जैसी संचार युक्तियों को मलकुंड में लगाया जाएगा.
- (तीन) स्थल पर निम्नलिखित बचाव उपकरणों का रहना :—
- (क) घायल कर्मों के व्यक्ति चालन की सुनिश्चित करने के लिए ट्राइपॉड और साज प्रणाली या कुछ अन्य पद्धति;
- (ख) टोकरी स्ट्रेचर या उसी प्रकार की युक्ति, आपात परिवहन के लिए घायल कर्मियों को ले जाने के लिए उपलब्ध होगी;
- (ग) उपबंध-एक में दिए गए प्राथमिक चिकित्सा उपस्कर और प्राशिक्षित कार्मिक शीघ्र ही उपलब्ध होंगे.
- (चार) नियोजक एबुलेंस, को उपलब्धता सुनिश्चित करेगा और अधिकतम निकटता से अनुसरण करेगा.
- (पांच) नियोजक यह सुनिश्चित करेगा कि समनुदेशित व्यक्ति के पास कम से कम दस लाख रुपये की जीवन बीमा पालिसी है और जिसका प्रीमियम नियोजक द्वारा संदत्त किया जाएगा.

8. पर्यचा स्वच्छता सुरक्षा पूर्वाधानियां.—नियोजक निम्नलिखित स्वच्छता के अवधि के परचात् मलनाली या मलविगलन कुंड से बाहर मलनाली या विगलन कुंड की सफाई में लगे किसी व्यक्ति के लिए निम्नलिखित परच स्वच्छता सुरक्षा पूर्वाधानियां सुनिश्चित करेगा :—

- (एक) दूषित कपड़ों को हटाने के लिए और धुलाई के साथ-साथ कपड़े सुखाने के लिए सुविधाएं देगा.
- (दो) साफ सफाई सामग्री में सम्मिलित होगी किन्तु यह जल, साबुन, हाथ धोने वाले साबुन तक सीमित नहीं होगी और परच सफाई सुरक्षा के लिए शरीर पर प्रयोग किए जाने के लिए पर्याप्त तथा चिकित्सीय रूप से अधिप्रमाणित त्वचा क्रीम होगी.
- (तीन) मलनाली की सफाई के कारण त्वचा पर कोई घाव/रगड़ या पीड़ित स्वसन अंग की समस्याओं का शीघ्र ही उपचार किया जाएगा.

अध्याय-दो

अस्वच्छ शौचालय

9. अस्वच्छ शौचालय.—मानव विष्टा पूर्णतः अपघटित रूप में उचारित होगी जब वह अरुचिकर गंध के बिना स्थायी सामग्री में परिवर्तित हो जाती है और मूल्यवान पादप पोषकों में अंतर्विष्ट हो जाती है.

अस्वच्छ शौचालय का सर्वेक्षण

10. अस्वच्छ शौचालय का सर्वेक्षण.—(1) प्रत्येक स्थानीय प्राधिकारी, उसकी अधिकारिता के भीतर अस्वच्छ शौचालयों का सर्वेक्षण करने के लिए और उनकी सूची का प्रकाशन करने के लिए एक समुचित समय अनुसूची तैयार करेगा.

(2) स्थानीय प्राधिकारी, उसकी अधिकारिता के अधीन अस्वच्छ शौचालयों के अस्तित्व पर सामुदायिक नेताओं और सफाई कर्मचारियों या स्वच्छता कर्मचारों के कल्याण के लिए उसके क्षेत्र में कार्य कर रहे गैर-सरकारी संगठनों की सहायता लेगा.

(3) स्थानीय प्राधिकारी, अस्वच्छ शौचालयों के संनिर्माण, अनुरक्षण या उपयोग के संबंध में गैर-सरकारी संगठनों सहित किसी व्यक्ति द्वारा पारित किसी शिकायत की, शिकायत फाइल करने के पन्द्रह दिन के भीतर जांच करेगा.

(4) स्थानीय प्राधिकारी, अपने मुख्य कार्यकारी अधिकारी के अधीन, सफाई कर्मचारियों या स्वच्छता कर्मचारों के समुदाय से कम से कम दो सदस्यों सहित जिनमें से एक महिला होगी और कम से कम एक सदस्य सिविल सोसाइटी समूहों से होगा, एक समिति का गठन करेगा.

(5) उपनियम (4) में निर्दिष्ट समिति, सर्वेक्षण की योजना बनाएगी और उसकी मानीटर करेगी तथा यह सुनिश्चित करेगी कि किए जा रहे सर्वेक्षण के साथ-साथ एक जागरूकता अभियान चलाया जाए.

(6) स्थानीय प्राधिकरण का मुख्य कार्यकारी अधिकारी, उसकी अधिकारिता के भीतर अस्वच्छ शौचालयों की एक प्रारंभिक सूची तैयार करेगा और उसे स्थानीय प्राधिकारी के कार्यालय के सूचना पट्ट पर प्रदर्शित करेगा तथा सूची के संबंध में, उस तारीख को निर्दिष्ट करते हुए जिस तक आक्षेप, यदि कोई हो, प्राप्त किए जा सकेंगे, आक्षेप आमंत्रित करते हुए दो स्थानीय समाचार-पत्रों में उसे प्रकाशित करेगा.

(7) स्थानीय प्राधिकारी, प्रारंभिक सूची पर प्राप्त शिकायतों और आक्षेपों की सुनवाई करने के लिए विनिर्दिष्ट समय और तारीख को एक बैठक का आयोजन करेगा और अस्वच्छ शौचालयों की सूची का अनुमोदन करेगा.

(8) अस्वच्छ शौचालयों की अंतिम सूची तैयार की जाएगी और स्थानीय प्राधिकारी द्वारा प्रकाशित की जाएगी, जो स्थानीय प्राधिकारी के कार्यालय के सूचना पट्ट पर उन्हें प्रदर्शित करेगा तथा दो स्थानीय समाचार-पत्रों जिसमें से एक प्रादेशिक भाषा में होगा, में प्रकाशित करेगा.

(9) स्थानीय प्राधिकारी, अस्वच्छ शौचालयों की सूची के अंतिम प्रकाशन के पन्द्रह दिन के भीतर अस्वच्छ शौचालय के अधिभोगी को ऐसे अस्वच्छ शौचालय को अधिनियम के प्रारंभ होने की तारीख से छह मास की अवधि के भीतर ध्वस्त करने या उसे स्वच्छ शौचालय में परिवर्तित करने की सूचना की तामील करेगा.

(10) उपनियम (9) में निर्दिष्ट ऐसी सूचना की एक प्रति निरीक्षक को भेजी जाएगी.

(11) उपनियम (9) में निर्दिष्ट सूचना, में केन्द्र सरकार और राज्य सरकार की स्कीमों के संबंध में जो हितग्राहियों को अस्वच्छ शौचालयों को ध्वस्त करने या उन्हें स्वच्छ शौचालयों में परिवर्तित करने के लिए प्रोत्साहन का हकदार बनाती है और उन स्कीमों के अधीन लाभ उठाने के लिए पात्रता के संबंध में तथा ऐसा लाभ उठाने की प्रक्रिया के संबंध में, जानकारी शामिल होगी.

(12) उपनियम (4) में निर्दिष्ट समिति जिला मजिस्ट्रेट को एक सर्वेक्षण रिपोर्ट प्रस्तुत करेगी जो, या इस प्रयोजन के लिए उसके द्वारा पदाभिहित कोई विभाग उसकी अधिकारिता के अधीन सभी स्थानीय प्राधिकारियों की समेकित रिपोर्टों को राज्य स्तरीय सर्वेक्षण समिति को प्रस्तुत करेगा।

(13) राज्य स्तरीय सर्वेक्षण समिति, सर्वेक्षण की रिपोर्ट को अस्वच्छ शौचालयों को शहरी और ग्रामीण क्षेत्रों में स्वच्छ शौचालयों में परिवर्तित करने की स्कीमों से संबंधित केन्द्रीय मंत्रालय/विभाग को प्रस्तुत करेगी।

(14) केन्द्र या राज्य सरकार की सुसंगत स्कीमों के अधीन पात्र हितग्राही ऐसी स्कीमों के अधीन अनुज्ञेय वितीय सहायता के लिए आवेदन कर सकेंगे।

(15) उपनियम (9) के अधीन अवधि के अख्यान के पश्चात् स्थानीय प्राधिकारी अस्वच्छ शौचालय के परिसर का निरीक्षण करावा सकेगा।

(16) यदि अधिभोगी ने न तो अस्वच्छ शौचालय को ध्वस्त किया है न ही उसे स्वच्छ शौचालय में परिवर्तित किया है तो स्थानीय प्राधिकारी उसको ध्वस्त करने के लिए आदेश करेगा तथा अधिभोगी से लागत को भू-राजस्व के बकायों के रूप में वसूल करेगा।

अध्याय-तीन

हाथ से मैला उठाने वाले कर्मियों का सर्वेक्षण

11. हाथ से मैला उठाने वाले कर्मियों का सर्वेक्षण.—(1) स्थानीय प्राधिकारी यह सुनिश्चित करेगा कि हाथ से मैला उठाने वाले कर्मियों का सर्वेक्षण करने वाले व्यक्तियों को पर्याप्त रूप से और यथोचित रूप से स्थानीय प्राधिकारी द्वारा उस विधि और रीति पर प्रशिक्षित किया गया है, जिसमें सर्वेक्षण संचालित किया जाएगा और उन्हें हाथ से मैला उठाने के विषय पर सुग्राही बनाया गया है।

(2) राज्य स्तरीय सर्वेक्षण समिति और जिला स्तरीय सर्वेक्षण समिति विभिन्न स्तरों पर विशेषकर ऐसे क्षेत्रों में जहां अस्वच्छ शौचालयों के सर्वेक्षण के दौरान अस्वच्छ शौचालय पाए गए हैं पर्याप्त अभियान चलाएगी।

(3) स्थानीय प्राधिकारी, हाथ से मैला उठाने वाले कर्मियों के पहचान करने के सामुदायिक नेताओं या सफाई कर्मचारियों या स्वच्छता कर्मचारों के कल्याण के लिए कार्य कर रहे गैर-सरकारी संगठनों को भी सहबद्ध करेगा।

(4) स्थानीय प्राधिकारी, हाथ से मैला उठाने वाले कर्मियों को स्वयं की घोषणा करने वाले केन्द्रों पर स्वयं की घोषणा करने के लिए जागरूकता अभियानों के माध्यम से आमंत्रित करेगा और अवधि के दौरान उन स्थानों पर जिनको स्थानीय प्राधिकारी द्वारा अधिसूचित किया जाएगा उनके ब्यौरों को सत्यापित करेगा।

(5) हाथ से मैला उठाने वाले कर्मियों की सूचियां यदि गैर-सरकारी संगठनों या अन्य व्यक्तियों या अधिकारणों द्वारा उपलब्ध कराई गई हैं, तो हाथ से मैला उठाने वाले कर्मियों को पहचान करने के लिए पूर्णतया सत्यापित किया जाएगा।

(6) अस्वच्छ शौचालयों या हाथ से मैला उठाने वाले कर्मियों की संख्या के डाटा के बीच किसी व्यक्ति या संगठन द्वारा बताए गए अंतर की दशा में, स्थानीय प्राधिकारी, प्रमाणकों द्वारा उन अस्वच्छ शौचालयों में सेवा कर रहे हाथ से मैला उठाने वाले कर्मियों के नामों को जानने के लिए द्वार से द्वार सर्वेक्षण करने का आदेश करेगा।

(7) स्थानीय प्राधिकारी, हाथ से मैला उठाने वाले कर्मियों को पहचान करने के लिए सफाई कर्मचारियों, स्वच्छता कर्मचारों या हाथ से मैला उठाने वाले कर्मियों के परिवारों का भी भ्रमण करेगा।

True copy

(8) इस प्रयोजन के लिए स्थानीय प्राधिकारी द्वारा पदाभिहित औद्योगिकियों द्वारा प्रणालियों द्वारा किए गए कार्य की नीचे उपदर्शित परिमाण तक यादृच्छिक चयन के आधार पर नमूनों को जांच की जाएगी :-

- (एक) ग्रामों में शत-प्रतिशत जांच.
- (दो) शहरों और नगरों में जहां अस्वच्छ शौचालयों सहित 1000 से कम गृहस्थ हैं शत-प्रतिशत जांच.
- (तीन) उन नगरों या शहरों में जिनमें 1000 से 9999 गृहस्थ अस्वच्छ शौचालयों सहित हैं प्रत्येक प्रणालि द्वारा सत्यापित घोषणाओं का 50 प्रतिशत.
- (चार) उन नगरों या शहरों में जिनमें 10000 गृहस्थ या अधिक गृहस्थ अस्वच्छ शौचालयों सहित हैं प्रत्येक प्रणालि द्वारा सत्यापित घोषणाओं का 33 प्रतिशत.
- (पांच) प्रवर्ग (तीन) और प्रवर्ग (चार) में, यदि प्राणिक द्वारा किए गए कार्य के नमूनों की जांच में 10 प्रतिशत से अधिक की त्रुटि का पता चलता है, तो पर्यवेक्षक द्वारा उसके कार्य की 100 प्रतिशत जांच की जाएगी.
- (9) इन अधिनियमों के अनुसरण में हाथ से मैला उठाने वाले कर्मियों की अनंतिम सूची में किसी नाम को शामिल करने या हटाने पर किसी व्यक्ति द्वारा आपत्ति की दशा में अनंतिम प्रकाशन से पंद्रह दिन की अवधि के भीतर, वह संबंधित स्थानीय प्राधिकारी द्वारा विहित प्रत्येक में आक्षेप फाइल कर करेगा.

(10) स्थानीय प्राधिकारी इस अधिनियम के अधीन हाथ से मैला उठाने वाले कर्मियों के सर्वेक्षण के दौरान उक्त सूची के प्रकाशन की रीति को भी अधिसूचित करेगा.

(11) स्थानीय प्राधिकारी आक्षेपों की जांच कारित करवाएगा और उसकी अधिकारिता में हाथ से मैला उठाने वाले कर्मियों की सूची को अंतिम रूप देने के लिए बैठक, यदि आवश्यक हो तो, करेगा.

(12) स्थानीय प्राधिकारी द्वारा अंतिम सूची के प्रकाशन के पश्चात् सूची पर किसी दावे या आक्षेप को सूची में जोड़ने या हटाने के लिये स्वीकार नहीं किया जाएगा परन्तु हाथ से मैला उठाने वाला कर्मों स्वयं के विषय में उसका हाथ से मैला उठाने वाला कर्मों होने की घोषणा करने का इकदार होगा.

(13) जिला मजिस्ट्रेट, तहसीलदार या खण्ड विकास अधिकारी से अन्यून अधिकारी को प्राप्त दावों और आक्षेपों की जांच करने के लिये और पदाभिहित पदाधिकारी द्वारा की गई जांच पर निष्कर्ष देने के लिये पदाभिहित करेगा तथा पदाभिहित प्राधिकारी यह सुनिश्चित करेगा कि—

- (एक) दावाकर्ता या आक्षेपकर्ता को सुने जाने का पर्याप्त अवसर दिया गया है;
- (दो) दावाकर्ता या आक्षेपकर्ता को उपनियम (15) में यथा उपबंधित अनुसार त्वरित सुनवाई की सात दिन से अन्यून सूचना दी गई है;
- (तीन) दावाकर्ता या आक्षेपकर्ता को उपनियम (14) में यथा उपबंधित अनुसार उसके दावे के समर्थन में दस्तावेजी साक्ष्य देने के लिये अनुज्ञात किया जाएगा;
- (चार) दावाकर्ता या आक्षेपकर्ता को किसी वकील, गैर-सरकारी संगठन या मित्र द्वारा प्रतिनिधित्व करने का अधिकार होगा, और

(पांच) दावाकर्ता या आक्षेपकर्ता को उपनियम (20) में उपबंधित किए गए अनुसार पदाभिहित प्राधिकारी द्वारा पारित आदेश की प्रति दी जाएगी.

(14) इन नियमों के अधीन दावे और आक्षेप फाइल करने के लिये प्रत्येक को आवेदकों को निर्दिष्ट स्थान पर मांग करने पर बिना किसी प्रकार के और स्थानीय प्राधिकारी की वेबसाइट के माध्यम से उपलब्ध कराया जाएगा तथा दावाकर्ता या आक्षेपकर्ता अपने दावे के समर्थन में दस्तावेजी साक्ष्य, यदि कोई हो, दे सकेगा.

344/17/15
344/17/15
344/17/15

(15) स्थानीय प्राधिकारी द्वारा पदाभिहित अधिकारियों द्वारा त्वरित सुनवाई की जाएगी।

(16) दारों का स्थापन करने के लिये पदाभिहित अधिकारी, यदि अपेक्षित हो तो नए स्थापन का आदेश कर सकेंगे।

(17) संक्षिप्त सुनवाई और ऐसे अतिरिक्त स्थापन (यदि आदेश किया गया है) के पश्चात्, अधिकारी यथास्थिति, दारों या आशेष को स्वीकार या अस्वीकार करते हुए समुचित आदेश पारित करेंगे और आदेश को एक प्रति संबंधित व्यक्ति को दी जाएगी।

(18) पदाभिहित पदाधिकारी द्वारा दारों और आशेषों का निपटारा करने के पश्चात् स्थानीय प्राधिकारी प्रारूप सूची में अपेक्षित संशोधन करेंगे और उन्हें जिला स्तरीय सर्वेक्षण समिति को उसके विचारार्थ संप्रेषित करेंगे।

(19) जिला स्तरीय सर्वेक्षण समिति, प्रत्येक स्थानीय प्राधिकरण, शहर से प्राप्त होने वाले कार्मियों की सूचियों को संकलित करवाएगी और ऐसे जिले के लिए होश से मैला होने वाले कार्मियों की सूची तैयार करेगी जिसे जिला कलेक्टर राज्य सरकार को भेजेगा।

(20) राज्य सरकार विभिन्न जिलों से प्राप्त होश से मैला होने वाले कार्मियों की सूचियां रखेगी, संकलित करेगी और होश से मैला होने वाले कार्मियों की सूची तैयार करेगी।

(21) होश से मैला होने वाले कार्मियों के रूप में कार्यरत कोई भी कार्मी स्थानीय प्राधिकारी द्वारा किए गए सर्वेक्षण के दौरान या उसके पश्चात् किसी भी समय विहित प्रारूप में होश से मैला होने वाले कार्मियों के रूप में पहचान किए जाने के लिए स्वयं घोषित कर सकेंगे और स्थानीय प्राधिकरण के मुख्य कार्यपालक अधिकारी या इस निमित्त उसके द्वारा प्राधिकृत किसी अन्य अधिकारी को आवेदन कर सकेंगे। आवेदन का उपलक्षण उपरोक्त-दो पर दिया गया है।

(22) होश से मैला होने वाले कार्मी की पहचान के लिए कोई न्यूनतम आय सीमा नहीं होगी और होश से मैला होने वाले कार्मी के रूप में पहचान किए जाने के लिए जाति या धर्म या आय या लिंग के संबंध में कोई प्रतिबंध नहीं होगा।

(23) उप नियम (22) के प्रयोजनों के लिए कोई व्यक्ति इस अधिनियम के प्रारम्भ होने पर या उसके पश्चात् होश से मैला होने वाले कार्मी के रूप में लगाया जाना चाहिए या या नियोजित किया जाना चाहिए या और उसने कम के कम दोन मास तक निर्धारित समय में कार्य किया हो।

(24) ओवरसियरों द्वारा यथा सत्यापित पहचान किए गए होश से मैला होने वाले कार्मियों की अनतिम सूची स्थानीय समाचार-पत्रों में संबद्ध स्थानीय प्राधिकरण द्वारा प्रकाशित की जाएगी और उसके अपने ही कार्यालय में और ऐसे अन्य स्थानों पर, जो समुचित समझे जाएं, प्रदर्शित की जाएगी।

(25) अनतिम सूची प्रकाशित करने समय, स्थानीय प्राधिकरण के सदस्यों और गैर सरकारी संगठनों या संकाई कार्मियों या संकाई कार्मियों के सामुदायिक नेता को उपलब्ध कराई जाएगी।

(26) अनतिम सूची प्रकाशित करने समय, स्थानीय प्राधिकरण जनता के सदस्यों से यह अपेक्षा करेगा कि वे स्थानीय प्राधिकरण द्वारा अधिसूचित में कम से कम 15 दिन की अवधि के भीतर सूची के विरुद्ध दावे और आक्षेप फाइल करें।

(27) जिला स्तरीय सर्वेक्षण समिति द्वारा अनतिम सूची के अनुसंधान के पश्चात् उसे संबद्ध कार्यालयों के सूचना पत्रों पर सत्यकत; प्रकाशित किया जाएगा और अनतिम सूची जिला प्रशासन तथा राज्य सरकार की वेबसाइट पर अपलोड की जाएगी।

12. पहचान किए गए होश से मैला होने वाले कार्मी, प्रत्येक कुटुंब से एक कार्मी, पहचान करने के ठीक बाद में 40,000 रुपये की नकद सहायता प्राप्त करने के लिए पात्र होगा। हितग्राही अधिकतम 7,000 रुपये की मासिक किस्तों में रकम प्राप्त करने के लिए अत्रिगत होगा।

3415
True copy

अध्याय-चार

निरीक्षक की शक्तियां

13. निरीक्षक की शक्तियां.—यदि किसी निरीक्षक के पास यह विश्वास करने का कारण है कि इस अधिनियम के अधीन कोई अपराध जो अधिनियम की धारा 5 या धारा 6 की उपधारा (2) या धारा 7 के अधीन परिभाषित है, होता है या उसके होने की संभावना है, तो वह उसका निरीक्षण, अन्वेषण करेगा या उसकी जांच कराएगा :—

- (1) यदि अपराध किसी अस्वच्छ शौचालय के सनिमार्ग, रखरखाव या उसके उपयोग से संबंधित है तो निरीक्षक, स्थानीय प्राधिकरण को इसकी रिपोर्ट करेगा जो इसके पश्चात् अधिनियम के उपबंधों के अनुसार कार्रवाई करेगा.
- (2) यदि अपराध हाथ से मैला ढोने वाले कर्मियों के नियोजन से संबंधित है तो निरीक्षक, स्थानीय प्राधिकरण को और साथ ही जिला मजिस्ट्रेट को रिपोर्ट भेजेगा.
- (3) स्थानीय प्राधिकरण, हाथ से मैला ढोने वाले ऐसे कर्मों का नाम सम्मिलित करने के लिए कदम उठाएगा जो, चाहे सर्वेक्षण के दौरान या उसके पश्चात् किसी भी समय, हाथ से मैला ढोने वाले कर्मियों की अन्तिम सूची में नियोचित पाया जाए और जब हाथ से मैला ढोने वाले किसी कर्मों का नाम अन्तिम सूची में जोड़ दिया जाता है तब मैला ढोने वाले कर्मियों को अधिनियम के उपबंधों के अधीन पुनर्वासित किया जाएगा.
- (4) यदि निरीक्षक को ऐसा प्रतीत होता है कि मलानानी या मल विगलन कुंड की परिसंकटमय सफाई को अपनाया जा रहा है, तो निरीक्षक ऐसे परिसंकटमय सफाई गुप्त रोकने के लिए आदेश करेगा और मामले की स्थानीय प्राधिकरण को रिपोर्ट करेगा.
- (5) निरीक्षक अपनी अधिकारिता के भीतर किसी संरचना, स्थल, स्थान या परिसर का परीक्षण उस समय कर सकेगा जब यह विश्वास करने के लिए कारण है कि ऐसे परिसर का मलानानी या मल विगलन कुंड की परिसंकटमय सफाई के लिए उपयोग किया जा रहा है या उपयोग किसी गया है या उपयोग किया जाने वाला है.
- (6) निरीक्षक किसी व्यक्ति का ऐसा साक्ष्य उसी जगह या अन्यथा ले सकेगा, जिसे वह अस्वास्थ्यकर शौचालय या मलानाली या मल विगलन कुंड से संसकत किसी परीक्षा या जांच के प्रयोजन के लिए आवश्यक समझे :
परंतु ऐसे व्यक्ति को किसी प्रश्न का उत्तर देने के लिए या उस ऐसे किसी साक्ष्य, जो अपराध में फंसाने की प्रवृत्ति रखता हो, देने के लिए विवश नहीं किया जाएगा.
- (7) निरीक्षक ऐसा कोई फोटोग्राफ, वीडियो क्लिप, नमूना, रिकॉर्ड प्राप्त कर सकेगा या प्राप्त करवा सकेगा या किसी ऐसी युक्ति, जिसमें इलेक्ट्रॉनिक युक्ति भी है, का प्रयोग करके, कोई स्कैन बना सकेगा या बनवा सकेगा जो वह इन नियमों के अधीन किसी परीक्षा या जांच के प्रयोजन के लिए आवश्यक समझे.
- (8) यह देखने पर कि कोई स्थानीय प्राधिकरण, व्यक्ति या अधिकरण परिसंकटमय सफाई में किसी व्यक्ति को लगा रहा है या नियोचित कर रहा है, तो निरीक्षक ऐसे प्राधिकरण, व्यक्ति या अधिकरण को निर्देश देगा कि वह ऐसे सफाई के कार्य को तुरंत रोक दे और इस संबंध में इन नियमों के उपबंध-तीन के रूप में उपाबद्ध प्ररूप में लिखित सूचना तामील करेगा.

अध्याय-पांच

राज्य निगरानी समिति

14. राज्य निगरानी समिति.—(1) राज्य निगरानी समिति ऐसी तारीख और ऐसे समय पर, उहाँ मास में कम से कम एक बार बैठक करेगी जो अध्यक्ष द्वारा नियत की जाए.

(2) बैठक सामान्यतः राज्य मुख्यालयों में आयोजित की जाएगी

(3) जहाँ समिति किसी ऐसे अन्य स्थान पर बैठक आयोजित करना आवश्यक समझती है वहाँ उन कारणों को जो लोखबद्ध किए जाएं ऐसी बैठकें अन्य स्थानों पर राज्य के भीतर आयोजित की सहेगी.

(4) सदस्य सचिव, समिति के सभी सदस्यों को न्यूनतम दस दिन की सूचना जारी करवाएगा और बैठक के दौरान विचार किए जाने वाली कार्य भी भेजेगा।

(5) ऐसे किसी कार्य पर, जो कार्य सूची में सम्मिलित नहीं है, अध्यक्ष की अनुमति के बिना विचार नहीं किया जाएगा।

(6) अध्यक्ष, उस प्रत्येक बैठक को, जिसमें वह उपस्थित रहेगा है, अध्यक्षता करेगा और उसकी अनुपस्थिति में, सदस्य, बैठक की अध्यक्षता करने के लिए उपस्थित वरिष्ठतम सदस्य को अध्यक्ष के रूप में चयन कर सकते हैं।

(7) किसी बैठक में कोई कारण तब तक नहीं दिया जाएगा जब तक कि समिति के कुल सदस्यों के कम से कम एक तिहाई सदस्य उपस्थित न हों :

परंतु यदि, किसी बैठक में, एक तिहाई सदस्यों से कम सदस्य उपस्थित हैं तो अध्यक्ष, उपस्थित सदस्यों को सूचित करते हुए और अन्य सदस्यों को रजिस्ट्रार सूचना भेजकर बैठक की तारीख से सात दिन से अल्पतम की तारीख तक बैठक को स्थगित कर

सकेंगा।

(8) आस्थित बैठक में कारण गणपूर्ति को ध्यान में लाए बिना निर्यात जाएगा।

(9) प्रत्येक बैठक को कार्यवाही में उपस्थित सभी सदस्यों को परिचित की जाएगी और पंजीकृत सूची में सूचित किया जाएगा कि आगामी बैठक में पूर्ति की जाएगी और उन्हें अध्यक्ष द्वारा हस्ताक्षरित किया जाएगा।

(10) कार्यवाही प्रक्रिया में कार्यवाही अधिलिखित किए जाएंगे जो स्थायी अभिलेख के रूप में रखे जाएंगे।

(11) कार्यवाही को एक प्रति केन्द्रीय निगामी समिति को सूचना देते हुए केन्द्रीय सरकार को पृष्ठीकृत की जाएगी।

उपबोध-एक

(नियम 7-देखिए)

प्रारंभिक उपचार सूचियाँ.—1. 150 कार्यवाहियों के लिये न्यूनतम एक प्रारंभिक उपचार सूची प्रत्येक कार्यवाही पर उपलब्ध कराई जाएगी और उसे बनाए रखा जाएगा जिससे वह कार्य समय के दौरान सहजता: पहुँच योग्य हो सके।

2. प्रारंभिक उपचार सूची के प्रारंभ पर लागू क्रम से सुनिश्चित की जाएगी और उसमें निम्नलिखित उपकरण होंगे, अर्थात्:—

(क) ऐसे कार्यवाहियों के लिये, जिनमें निम्नलिखित कार्यवाहियों की संख्या 50 से अधिक है, प्रत्येक उपचार सूची में निम्नलिखित उपकरण होंगे:—

(एक) 6 लघु जीवाणुहीन मरहम पट्टियाँ;

(दो) 3 मध्य आकार वाली जीवाणुहीन मरहम पट्टियाँ;

(तीन) 3 विरुद्ध आकार वाली जीवाणुहीन मरहम पट्टियाँ;

(चार) 3 विरुद्ध आकार वाली बर्न मरहम पट्टियाँ;

(पाँच) 1 (30 मि. लि.) बोलत जिसमें दो प्रतिशत एन्कोहालिक विलेपन आयोजित हो;

(छह) (30 मि. लि.) सेलवालाटाइल से युक्त बोलत जिसमें लेबल पर खुलाक और उसे देने का ढांग उपदर्शित हो;

(सात) 1 सफेदश नखर;

(आठ) 1 (30 मि. ग्रा.) पोटैशियम परमैंगनेट क्रिस्टल की बोलत

(नौ) 1 कैंची;

(दस) महानिदेशक, कारखाना सलाह सेवा और भ्रम संस्थान, भारत सरकार द्वारा जारी प्रथम उपचार पत्रक की एक

प्रति;

347
 31/1/15
 TRUE COPY

- (क) प्राथमिक शिक्षण घेटी मं उपर्युक्त घेरा (क) और घेरा (ख) मं यथा वर्णित से भिन्न कोई अन्य उपकरण या पदार्थ नहीं रखा जाएगा।
- (ख) को निकटतम अस्पताल ले जाने के लिये एक उपयुक्त मोटर वाहन सहज रूप से उपलब्ध रखा जाएगा।
- (ग) जहाँ कार्यस्थल ऐसे स्थान में स्थित है, जो शहरों या नगरों में नहीं है, जहाँ व्यक्ति या अचानक बीमार हुए व्यक्ति को निकटतम अस्पताल ले जाने के लिये एक उपयुक्त मोटर वाहन सहज रूप से उपलब्ध रखा जाएगा।
- (घ) ऐसे कार्यस्थल में, जिसमें नियोजित कर्मचारियों की संख्या 500 या अधिक है और शिक्षण सुविधाएँ कार्यस्थल से अलग दूरी पर उपलब्ध नहीं हैं, प्राथमिक सहयोगिता पोस्ट की स्थापना की जाएगी और प्रशिक्षित कमांडर द्वारा संचालित किया जाएगा और जब कर्मकार कार्य पर हो तो वह द्यूटी पर रहेगा तथा सभी समय उपलब्ध रहेगा।
- (ङ) ऐसे कार्यस्थल में, जिसमें कर्मचारियों की संख्या 150 या अधिक है, प्राथमिक शिक्षण घेटी का भारतीयक व्यक्ति ऐसा व्यक्ति होगा, जो प्राथमिक सहयोगिता उपचार में प्रशिक्षित हो।
- (च) प्राथमिक शिक्षण घेटी ऐसे उत्तरदायी व्यक्ति के भारतीयक के भारतीयक में रखी जाएगी, जो कार्यस्थल के कार्य समय के दौरान आसानी से उपलब्ध है।
- (छ) उपकरणों को गुंथ प्राप्त करने के लिये, जब आवश्यक है, पर्याप्त व्यवस्थाएँ करनी होंगी।
- (फ) उपर्युक्त शब्द शिक्षण घेटी प्राथमिक शिक्षण घेटी का अर्थ है:
- (क) जले पर लगाने का महाम;
- (ख) एरियन की 100 गीलियाँ (5 ग्राम प्रत्येक) की एक बोतल;
- (ग) एक प्रति;
- (घ) कारखाना सलाहकार सेवा और श्रम संस्थान, महानिदेशक/भारत सरकार द्वारा जारी प्राथमिक सहयोगिता प्रतिक्रिया की (फारम) 1 की;
- (ङ) प्रोटिजियम परमैगनेट फिस्सल की एक बोतल (30 मि. ली.);
- (च) 1 साप के देश का नशर;
- (छ) विपकने जाले लाटर का एक सेल;
- (ज) 1 बोतल (60 मि. ली.), जिसमें साबुनोलाइट हो, जिसके लेबल पर प्रयोग की मात्रा और सील उपस्थित हो;
- (झ) 1 बोतल (60 मि. ली.), जिसमें दो प्रतिशत एल्कोहल विलयन आयोडीन हो;
- (झ) 6 पैकेट (आई. एस. एम. जी. एस.) जीवाणुहीन रुई कन;
- (घ) 6 बड़ी आकार की जीवाणुहीन निंबल-पट्टियाँ;
- (ग) 6 बड़ी आकार की जीवाणुहीन निंबल-पट्टियाँ;
- (ङ) 6 मध्यम आकार की जीवाणुहीन महाम-पट्टियाँ;
- (च) 12 जीवाणुहीन छोटी महाम-पट्टियाँ;
- उपकरण होंगे —
- (ख) कार्यस्थल, जिसमें कर्मचारियों की संख्या 50 से अधिक है, के प्रत्येक प्राथमिक सहयोगिता बोक्स में निम्नलिखित
- (क) उपर्युक्त शब्दक रोगप्ररोधक विलयन की एक बोतल
- (ख) जले पर लगाने का महाम;
- (ग) 1 बोतल जिसमें एरियन की 100 गीलियाँ (प्रत्येक 5 मि. ग्रा.) हों;

अध्याय 2

[विधम 11(2) देखिए]

रक्ष-सौभाग्य प्रश्न

हाथ से मूला उठाने वाले व्यक्तियों की पहचान

(कार्यालय प्रयोग के लिए)

[Empty box for office use]

हाथ से मूला उठाने वाले व्यक्तियों का फोटो

[Empty box for photo of individuals]

राज्य का नाम

जिला

नगरपालिका

पंचायत

नाम

वाङ्

गोब

हाथ से मूला उठाने वाले व्यक्तियों के परिवार का फोटो (पोस्टकार्ड आकार का फोटो विम 6" x 4")

[Large empty box for family photo]

1. हाथ से मूला उठाने वाले व्यक्तियों का नाम
2. पिता/माता/पति या पत्नी का नाम
3. आय
4. लिंग : पुरुष
5. शैक्षिक प्रस्थिति : (उपर्युक्त बाक्स में का चिह्न लगाए)

[Empty box for gender]

[Empty box for income]

(एक) (क) शिक्षित [Empty box] (ख) अशिक्षित [Empty box]

(दो) यदि शिक्षित है तो, शिक्षा का स्तर :-

(क) प्राप्त शिक्षा : कक्षा 1-5 [Empty box] कक्षा 6-10 [Empty box] कक्षा 11-12 [Empty box]

[Empty box] कक्षा 12 से अधिक

True copy // 349

हो	नहीं

किस

(उपरोक्त वाक्य में ✓ का चिह्न लगाए)

10. (क) क्या आपने सरकार को पुनर्वास स्कीमों से कोई फायदा प्राप्त किया है?

(ख) हाँ (घ) नहीं

(क) क्या अ.जा./अ.व.जा./अ.पि.व./अन्य से है (ग) उप जाति (घ) धर्म

9. सामाजिक पृष्ठ भूमि :

8. आप इस व्यवसाय में कितने समय से हैं :-

(ग) संविदा आधार पर (घ) वंशपाती

(क) स्थायी आधार (ख) अस्थायी आधार पर

(2) निधोजन :

(घ) नगर निगम

(ख) केन्द्र सरकार (ग) राज्य सरकार

(पांच) अन्य (निर्दिष्ट करें)

(तीन) संविदाकार (चार) अस्पताल, कार्यालय, आदि किसी संस्थान

(एक) व्यावसायिक कर्तृत्व (दो) समुदाय/कर्तृत्व का समूह

(क) निजी :-

(1) निधोजन :

7. निधोजन की प्रस्थिति :-

(ख) रेलवे ट्रेक से (ग) शीव गड्ढावर से

(दो) बिना उपचारित मानव मल-मूत्र को सफाई : (क) खुले नाले से

(एक) अस्वच्छ शौचघर से मानव मल-मूत्र को ले जाना/निपटान/सफाई

6. व्यवसाय :

(ख) यदि हां, तो नाम (उचित बॉक्स में का ✓ चिन्ह अंकित करें) :

अनुक्रमिक	स्कीमों के नाम	रूपये
1	मैला उठाने वाले कर्मियों की मुक्ति और पुनर्वास के लिए राष्ट्रीय स्कीम (एनएसएलआरएस)	
2	हाथ से मैला उठाने वाले कर्मियों के पुनर्वास के लिए स्वरोजगार स्कीम (एसआरएमएस)	
3	कोई अन्य स्कीम के नाम विनिर्दिष्ट करें	

(ग) यदि हां, तो क्या उपरोक्त स्कीम के माध्यम से वित्तपोषित परियोजना चल रही है :

हां	नहीं	यदि हां, तो मासिक आय (रु.)
		₹

(घ) ज्ञात नहीं,

11. (क) क्या आप मैला उठाने से भिन्न किसी उपजीविका में लगे हुए हैं? हां नहीं

(ख) यदि हां, तो विनिर्दिष्ट करें :

12. कोई अन्य कौशल जो रखते हैं :

(एक) सनिर्मण	<input type="checkbox"/>	(दो) बढ़ईगरी	<input type="checkbox"/>
(तीन) वाहन चालन	<input type="checkbox"/>	(चार) भोजन बनाना	<input type="checkbox"/>
(पांच) कपड़े सिलना	<input type="checkbox"/>	(छह) (विनिर्दिष्ट करें)	<input type="checkbox"/>

13. प्रस्तावित वैकल्पिक उपजीविका (कृपया विनिर्दिष्ट करें)

हाथ से मैला उठाने में लगे हुए व्यक्ति का नाम और पता

पिनकोड

संपर्क दूरभाष/मोबाइल सं.

हाथ से मैला उठाने में लगे हुए व्यक्ति के

हस्ताक्षर/अंगूठे का निशान

डाटा संदी आपरेटर के हस्ताक्षर

"True copy"

(1)	अनुक्रममांक	खुले गावों/रेल मार्गों/अन्य	दोष से मुला उठाने वाले का
(2)	खुले गावों/रेल मार्गों/अन्य स्थानों की अवस्थिति विवरण	अस्वच्छ शौचालयों से मूल	मासिक वेतन/मजदूरी (रु.)
(3)		बढ़िया जा रहा है	
(4)			

3. खुले गावों (ओडी)/रेल मार्गों/अन्य स्थानों के ब्यौरे :

(1)	अनुक्रममांक	सामुदायिक अस्वच्छ शौचालय	अवस्थिति	दोष से मुला उठाने वाले
(2)	का नाम	के स्वामी (संभालन/अभिभारण)		मासिक वेतन/मजदूरी (रु.)
(3)				
(4)				
(5)				
(6)				

2. सामुदायिक अस्वच्छ शौचालयों (सीआईएल) के ब्यौरे :

टिप्पण : कृपया दोष से मुला उठाने में लगी हुए व्यक्ति द्वारा साफ किए जा रहे व्यक्ति अस्वच्छ शौचालयों के विस्तृत वर्णन दे यदि आपको आतिथिक जानकारी लिखने की आवश्यकता हो तो कृपया इस पृष्ठ की छायाप्रति करें और सर्वेक्षण प्ररूप के साथ संलग्न करें।

दोष से मुला उठाने में लगी हुए व्यक्ति द्वारा साफ किए जा रहे व्यक्ति अस्वच्छ शौचालयों की कुल संख्या :

(1)	अनुक्रममांक	अस्वच्छ शौचालय के स्वामी का नाम	अवस्थिति	दोष से मुला उठाने वाले
(2)				मासिक वेतन/मजदूरी (रु.)
(3)				
(4)				
(5)				

1. व्यक्ति अस्वच्छ शौचालय (आईआईएल) के ब्यौरे :

अस्वच्छ शौचालय के ब्यौरे—

नाम और तारीख (कोड सं. के साथ) :

प्रमाणक के हस्ताक्षर :

नाम और तारीख (कोड सं. के साथ) :

परीक्षक के हस्ताक्षर :

नाम और तारीख (कोड सं. के साथ) :

353
CO STAFFS
//True copy//

.....
.....
.....

(तीन) अतिक्रमण के व्यौर

(दो) अतिक्रमण की तारीख

(एक) अतिक्रमण का स्थान

के अनुसार दी गयी है :-

यतः आपकी उक्त अधिनियम की धारा 2(1)(घ) के उपबंधों तथा उसके अधीन बनाये गये नियम, ह्राथ से मैला उठाने वालों के नियोजन का प्रतिबंध और उनका पुनर्वासि नियम, 2013 का अतिक्रमण करने की सूचना निम्नलिखित व्यौरों

यतः मध्यप्रदेश सरकार के अधिनियम की धारा 7 के उपबंधों के प्रवर्तन की तारीख के रूप में 2-9-2014 अधिसूचित की है:

करना :

या अपत्यक्ष रूप से, किसी मलनाली या किसी मल विगलन कुंड की परिसंकेतमय सफाई के लिये न तो लगाएगा और न ही नियोजित सरकार अधिसूचित करे, जो इस अधिनियम की प्रारंभ की तारीख से एक वर्ष के बाद की नहीं होगी, किसी व्यक्ति को प्रत्यक्ष रूप से अधिनियम की धारा 7 उपबंधित करती है कि कोई भी व्यक्ति, स्थानीय प्राधिकारी या कोई अधिकरण, ऐसी तारीख से, जो राज्य

मलनालियाँ और मल विगलन कुंडों की परिसंकेतमय सफाई.

इसके पश्चात् अधिनियम के रूप में निर्दिष्ट है) के अधीन सूचना :

अधिनियम के रूप में निर्दिष्ट है) और ह्राथ से मैला उठाने वालों के नियोजन का प्रतिबंध और उनका पुनर्वासि नियम, 2013 (जो इसमें विषय : ह्राथ से मैला उठाने वालों के नियोजन का प्रतिबंध और उनका पुनर्वासि अधिनियम, 2013 (जो इसमें इसके पश्चात्

संदर्भ दिनांक

[ह्राथ से मैला उठाने वाले के नियोजन का प्रतिबंध और उनका पुनर्वासि नियम, 2014 की धारा 13(8) के अधीन]

सूचना

धारा 20 के अधीन निरीक्षक का कार्यालय (क्षेत्र का नाम)

ह्राथ से मैला उठाने वालों के नियोजन का प्रतिबंध और उनका पुनर्वासि अधिनियम, 2013 की

उपबंध-तीन

No. F- 12-32-2013-4-XXV.—In exercise of the powers conferred by sub-section (1) of section 36 of the Prohibition of Employment as Manual Scavengers and their Rehabilitation Act, 2013 (No. 25 of 2013), the State Government, hereby, makes the following rules, namely:—

. RULES
CHAPTER-1
GENERAL .

1. **Short title and commencement.**—(1) These rules may be called the Madhya Pradesh Prohibition of Employment as Manual Scavengers and their Rehabilitation Rules, 2015.

(2) They shall come into force from the date of their publication in the Madhya Pradesh Gazette.

2. **Definitions.**— (1) In these rules, unless the context otherwise requires,—

(a) "Act" means the Prohibition of Employment as Manual Scavengers and their Rehabilitation Act, 2013 (25 of 2013);

(b) "Cleaning device" means and shall include but not limited to the equipments referred to in rule 5, whether manually or mechanically propelled which can be used to :-

(i) clean or enable the transport or flow of sewage in sewers or septage from septic tanks; and

(ii) avoid direct manual contact with such sewage or material ;

(c) (i) " District Level Survey Committee" means the Committee referred to in rule 11 (2), 11 (18) and 11 (19) with the following composition :—

(1) District Magistrate	—	Chairman
(2) District Level Officer dealing with Scheduled Castes Affairs.	—	Member Secretary
(3) District Statistical Officer	—	Member
(4) District Level Officer of Urban Development Department.	—	Member
(5) One representative of railway Authority	—	Member
(6) Upto two representatives of Non-Government Organisations working For Welfare of Manual Scavengers and Safai Karamcharis to be nominated by the District Magistrate.	—	Member
(7) Upto two community representatives of whom one should be a woman to be nominated by the District Magistrate	—	Member

(ii) **Functions of the District Level Survey Committee:**

(i) to monitor and oversee the survey process at District level;

(ii) to distribute the materials for awareness campaign to designated place;

- (iii) to arrange publicity through local newspapers etc. about the survey;
- (iv) to distribute translated survey material to designated place under its jurisdiction;
- (v) to approve final list of manual scavengers for all towns, cities and villages in the district;
- (vi) Publication of final consolidated list of the manual scavengers in the district.
- (d) "Enumerator" means any person engaged by a local authority for the purpose of survey or verification of manual scavengers;
- (e) "Inspector" means a person appointed as inspector by the State Government as per the provisions of sub section (I) of section 20 of the Act;
- (f) "Overseer" means an officer engaged by a local authority to exercise the powers and perform the duties under these rules.
- (g) "Protective gear" means personal safety gear and safety devices that are to be provided, worn or used by safai karamcharis or sanitary workers in respect of cleaning of sewers and septic tanks that may be necessary for the specific nature of work to be carried out, as including and not limited to the materials referred to in Rule 4-
- (i) avoid any exposure of human skin to substances which can lead to diseases, along with all breathing equipment which prevents inhalation of gases which can lead to diseases, and, also includes any sensory equipment for detection of gases present inside the sewers or septic tanks;
- (ii) avoid any injuries while carrying out cleaning work.
- (h) "Safai Karamchari" or "Sanitation Worker" means any person engaged in or employed for any sanitation work other than domestic work;
- (i) "Safety precautions" shall include, but not be limited to, the precautions referred to in rule 6, and all steps necessary to reduce the risk to the person and to avoid contraction of diseases and injuries by the persons engaged in cleaning of sewers and septic tanks due to exposure to sewage or any other material in any physical state (solid, liquid or gas) inside the sewers or septic tanks and while entering sewers or septic tanks;
- (j) (i) "State Level Survey Committee" means the Committee referred to in rules 10(12), 10(13) and 11(2) with the following composition:—
- | | | |
|-----------------------------------------------------------------------------------------------------------------------------------------------------------------------------------------------------------------------------------------------------------|---|------------------|
| (1) Additional Chief Secretary or Principal Secretary,
Nominated by the State Government | — | Chairman |
| (2) Principal Secretary/Secretary dealing with Scheduled
Castes, if the Committee is Chaired by Additional
Chief Secretary. If Principal Secretary, Scheduled
Castes Welfare himself is the Chairman then Director,
Scheduled Castes Welfare. | — | Member Secretary |
| (3) Director, Economics and Statistics | — | Member |
| (4) Secretary, Urban Development and Environment
Department | — | Member |
| (5) Regional Director, Census Operations | — | Member |

- | | | | |
|-----|-----------------------------------------------------------------------------------------------------------------------------------------------------------------|---|--------|
| (6) | One representative of railway authority | — | Member |
| (7) | Upto two representatives of Non Government Organisations working for Welfare of Manual Scavengers and Safai Karamcharis to be nominated by the State Government | — | Member |
| (8) | Upto two community representatives of whom one Should be woman to be nominated by the State Government | — | Member |
- (iii) **Functions of the State Level Survey Committee:—**
- (i) to monitor and oversee the survey process at state level;
 - (ii) to distribute the materials for awareness campaign to designated place;
 - (iii) to arrange publicity through local newspapers etc. about the survey;
 - (iv) to distribute translated survey material to designated place under its jurisdiction;
 - (v) to approve final list of manual scavengers for all Towns, Cities and Villages in the State;
 - (vi) publication of final consolidated list of the manual scavengers in the State.

(2) Words and expressions used and not defined in these rules but defined in the Act, shall have the same meanings as assigned to them in the Act.

CHAPTER-II

OBLIGATIONS OF EMPLOYER TOWARDS EMPLOYEES ENGAGED IN THE CLEANING OF SEWER OR SEPTIC TANK

3. Obligations of Employers :

(1) No person shall be allowed to clean a sewer manually, with the protective gear and safety devices under these rules except:

- (a) for the removal of concrete or Fibre Reinforced Plastic (FRP) or damaged manhole door where mechanical equipments cannot be put into operation;
- (b) for inter-linking the newly laid sewer main with the existing sewer main, in case of sewer of size of more than 300 mm diameter;
- (c) for removal of submersible pump sets fixed at the bottom of the suction wells;
- (d) for the reconstruction of the manhole or rectification of the sewer main;
- (e) any circumstance, when it is absolutely necessary to have manual sewage cleaning, after the Chief Executive Officer of the local authority has permitted to do so after recording in writing the specific valid reasons for allowing such cleaning;
- (f) For the purposes of clauses (c) and (d) of sub-rule (1), before allowing entry of a person in the sewer, sewage shall be totally emptied.

4. Provisions of Protective gear and Safety devices.- Any person engaged to clean a sewer or a saptic tank shall be provided by his employer, protective gear and safety devices including, bnt not limited to ,the following:—

- (1) Air com pressor for blower
- (2) Air iive breathing apparatus
- (3) Air line respirator with manually operated air blower
- (4) Air purifier Gas mask/chin cortege
- (5) Artificial respiration/Reticulate
- (6) Barrier caution tape
- (7) Barrier cream
- (8) Barrier cone
- (9) Blower
- (10) Breathe mask
- (11) Breathing Apparatus
- (12) Caution board
- (13) Chlorine mask
- (14) Emergency medical oxygen resuscitator Kit
- (15) First Aid Box
- (16) Face Mask
- (17) Gas Monitor (4 gases)
- (18) Guide pipe Set
- (19) Full body wader suit
- (20) Fishing wader suit atteched with boots
- (21) Hand gloves
- (22) Hand Lamp
- (23) Helmet
- (24) Helmet demolishing
- (25) Lead acetate paper
- (26) Life guard pad
- (27) Modular Airlines Supply Trolley System
- (28) Normal face Mask
- (29) Nylon rope ladder 5 minters
- (30) Nylon safety belt
- (31) Poeket book
- (32) Port oxy
- (33) Raincoat
- (34) Reflecting Jacket
- (35) Safety belt
- (36) Safety body elothing
- (37) Safety body harness
- (38) Safety goggles
- (39) Safety Gumboots
- (40) Safety helmet
- (41) Safety showers
- (42) Safety torch
- (43) Safety Tripod Set
- (44) Search light

5. The Local Authority.—The local authority shall ensure that the following cleaning devices are used by persons engaged in cleaning sewer or septic tank including but not limited to the following:—

- (1) Sewer Line cleaning Bucketing Machiue
- (2) Jetting Machine (Gulley Emptier)

//True copy//

- (3) Suction Machine (Gulley Emptier)
- (4) Combined Machine (Jetting cum Suction)
- (5) Deep Suction Combined Machine (Jetting cum Suction Machine)
- (6) Manual Hand Operated Trolley Mounted Grab Bucket
- (7) Hydraulic operated Trolley Mounted Grab Bucket
- (8) Truck Mounted Motor and Winch Operated Grab Bucket Machine
- (9) Fixed structure Mounted Motor and Winch Operated Grab Bucket Machine
- (10) Rickshaw Mounted (Winch and Motor Operated Desilting Machine for wet wall
- (11) Rickshaw Mounted Winch and Auxiliary Engine Operated Desilting Machine for manhole
- (12) Escort Hydra Crane Mounted Hydraulic Winch Operated Grab Bucket Desilting Machine
- (13) Manual rods, shovels, spades, drainage cleaning machines and steel scrapers with handles
- (14) Hoses and washing instruments.

6. **The Protective gear and Safety devices.**—(1) All protective gear and safety devices under these rules shall be checked every six months and necessary repair or replacements shall be made by the employer who engages a person or cleaning a sewer or a septic tank.

(2) Comfortable body suits shall be made available to the worker who has to enter sewers or septic tanks for their cleaning. The employer shall provide full body suit to worker entering manhole of depth more than five feet and alterably, partial fishing wader suits to those entering manhole of depth less than five feet.

(3) The employer shall also ensure the following safety precaution before a person is engaged in the cleaning of a sewer or septic tank, namely:—

- (a) There shall be minimum of three employees present all the time, one of whom shall be a supervisor;
- (b) The atmosphere within the confined space shall be tested for oxygen deficiency and toxic and combustible gases including but not limited to poisonous gases like Hydrogen Sulphide, Carbon Monoxide, Methane and gasoline vapours, through detection tests including the following :—
 - (i) lowering a detector lamp into the manhole.
 - (ii) inserting wet lead acetate paper which changes colour in the presence of Hazardous Gases.
 - (iii) detection of gases through gas detector masks.
- (c) Before starting the cleaning under sub-rule(1) the supervisor referred to in clause (a) of sub-rule (3) has inspected and determined if the sewerline serves any industries nearby to anticipate any hazardous atmosphere that may be encountered;
- (d) The condition of metal rung ladders and the side walls of the manhole shall be checked to see if there is any danger of collapse;
- (e) Traffic and pedestrian barricades are provided all the times;
- (f) A flag man should be stationed at least 50 feet ahead of a site and should be visible to incoming traffic for at least 500 feet;
- (g) Regular medical check-up of sewage workers which shall include the examination of respiratory organs, skin injuries and other occupational diseases and injuries for their treatment to ensure that sewage workers afflicted with such diseases or injuries do not enter sewers for cleaning;
- (h) Regular vaccination against respiratory and skin diseases and other occupational diseases to which these workers are prone due to exposure to harmful substance and gases in sewers;

- (i) All employees who are present on-site during cleaning work are given training and adequately familiarized with the knowledge to operate all equipments involved in cleaning work, to avoid injuries or diseases associated with such work and to take necessary steps in case of emergency arising at the place of work and the training shall be conducted every two years and the employees shall be familiarized with any changes in method and technique with respect to the above.
- (j) The supervisor possesses and keeps handy the names, addresses and telephone numbers of the nearest hospitals or clinics;
- (k) Cleaning of a sewer or a septic tank shall be done: (i) only in day-light; and (ii) for a duration not exceeding ninety minutes, at a stretch. There shall be a mandatory interval of thirty minutes between two stretches;
- (l) Identify and close off or reroute any lines that might carry harmful substances to, or through the work area;
- (m) Ensure that written operating and rescue procedures are displayed at the entry site;
- (n) If the entry is made through a top opening, use a hoisting device with a harness that suspends a person in an upright position and a mechanical device shall be available to retrieve personnel from vertical spaces more than five feet deep;
- (o) At least one person trained in first aid and cardiopulmonary resuscitation should be immediately available during any confined space job;
- (p) Oxygen content in the manhole must be at least 19.5% in the confined space of the manhole measures at all levels (bottom, middle and top) and no person enters the manholes if oxygen level is below 19.5% and more than 21 % ;
- (q) Manhole shall be opened at least one hour before the start of operation;
- (r) The open manhole shall be properly fenced or barricaded to prevent any person, specially children, from accidentally falling into the sewer. Dummy cover with welded fabric or wire -net may be used;
- (s) All workers use the safety gear and safety devices before entering the sewer line;
- (t) Structure Safety of the manhole rungs or steps must be tested before entering the manhole;
- (u) Portable aluminium ladder is available during the work period where necessary and the portable ladder is properly seated or fixed during use;
- (v) No material or tools are located near the edge which can fall into the manhole and injure the workman;
- (w) Equipment used during sewer cleaning are explosion and fire proof;
- (x) Smoking, open flames are prohibited inside the manhole as well as in the immediate vicinity of open manholes;
- (y) In the event of a sudden or unpredictable atmospheric change, an emergency escape breathing apparatus with atleast a 10 minute air supply is worn;

The Safety Precautions.—The employer shall ensure the following safety precautions at the time when the person is engaged in the cleaning of a sewer or a septic tank:-

- (i) Portable fans and air blowers with batteries in good working condition with a back up capacity of more than the estimated duration of the entry of the person in the sewer, shall be carried into sewers for

ventilation and a ventilation source shall be installed at the mouth of the manhole.

- (ii) Flashlights and communication devices such as two-way radios shall be carried into sewers.
- (iii) Presence of the following rescue equipment at the site:-
 - (a) A tripod and harness system, or some other method ensuring manoeuvring of an injured worker to the surface;
 - (b) A basket stretcher or similar device, shall be available for moving the injured worker to emergency transportations;
 - (c) First aid equipment as given in Annexure-I and trained personnel shall be immediately available.
- (iv) The employer shall ensure availability of ambulance and follow-up in close proximity.
- (v) The employer shall ensure that the assigned person has life insurance policy of at least ten lakh rupees and the premium for which shall be paid by the employer.

8. **The post cleaning safety precautions.**—The employer shall ensure the following post-cleaning safety precaution after a person engaged in the cleaning of a sewer or a septic tanks comes out of the sewer or septic tanks after a session of cleaning:-

- (i) Provide facilities for removal of contaminated clothing and for wash-up as well as cleaning and dry clothing.
- (ii) Wash-up material shall include but not be limited to water, soaps, hand sanitizers and adequate and medically authenticated skin cream for applying on the body for post cleaning safety.
- (iii) Any cuts/ bruises on the skin or problems with a respiratory organ suffered on account of cleaning of sewer shall be immediately cured.

CHAPTER-II INSANITARY LATRINES

9. **Insanitary Latrines.**—Human excreta shall be treated as fully decomposed when it eventually becomes stable material with no unpleasant smell and containing valuable plant nutrients.

SURVEY OF INSANITARY LATRINES

10. **Survey of Insanitary Latrines**—(1) Every local authority shall draw a suitable time schedule for carrying out survey of insanitary latrines within its jurisdiction and the publication of their list.

(2) The local authority shall take the assistance of the community leaders and non Governmental Organizations working in the area for the welfare of the Safai Karamcharis or sanitary workers, on the existence of insanitary latrines in the area under its jurisdiction.

(3) Any complaint filed by any person including a non Government organization, regarding the construction, maintenance or use of insanitary latrine, shall be inquired by the local authority within fifteen days of filing the complaint.

(4) The local authority shall constitute a Committee under its Chief Executive Officer with at least two members from the community of Safai Karamcharis or sanitary workers, one of whom shall be a woman and at least one member from the civil society group.

1400 SURV
True copy
360

(5) The Committee referred to in sub-rule (4) shall plan and monitor the survey and ensure that an awareness campaign is carried out simultaneously with the survey that is conducted.

(6) The Chief Executive Officer of the local authority shall prepare an initial list of insanitary latrines existing in his jurisdiction and display the same at the notice board of the office of the local authority and publish in two local daily newspaper, inviting the objection, specifying the date by which the objections, if any, to the list, shall be received.

(7) The local authority shall cause to hold a meeting on the due date as specified to hear the complaints and objection received on the initial list and approve the final list insanitary latrines.

(8) The final list of insanitary latrines shall be prepared and published by the local authority which shall display the same at the notice board of office of the local authority and publish in two local newspapers, one of which shall be in the vernacular language.

(9) The local authority, within fifteen days of final publication of list of insanitary latrines, shall serve a notice on the occupier of the insanitary latrines to either demolish such insanitary latrines or convert it into a sanitary latrine within a period of six month from the date of commencement of the Act.

(10) A copy of such notice referred to in sub-rule (9) shall be send to the inspector.

(11) The notice referred to in sub-rule (9) shall include information regarding the schemes of the Central and State Government which entitle the beneficiaries to incentives for the demolition of insanitary latrines or conversion to sanitary latrines; and other information regarding the eligibility to avail the benefits under those Schemes and the procedure for availing such benefits.

(12) the Committee referred to in sub-rule(4) shall submit the survey report to the District Magistrate, who, or any department designated by him for this purpose, in turn, shall submit the consolidated report of all local authorities under his jurisdiction to State Level Survey Committee.

(13) The State Level Survey Committee shall furnish the report of the survey to the Central Ministry/ Department dealing with the Schemes of conversion of insanitary latrines into sanitary latrines for the urban and rural areas.

(14) The eligible beneficiaries under the relevant Schemes of the Central or State Government may apply for the admissible financial assistance under such schemes.

(15) After the expiry of the period under sub-rule (9), the local authority shall have the premises of the occupier of insanitary latrine inspected.

(16) If the occupier has neither demolished nor converted the insanitary latrine into a sanitary latrine, the local authority shall order for its demolition and recover the cost from the occupier as arrears of land revenue.

Chapter- III

SURVEY OF MANUAL SCAVENGERS

The Survey of Manual Scavengers.—(1) The local authority shall ensure that the persons conduction the survey of manual scavengers shall be adequately and appropriately trained by the local authority on the method and manner in which the survey shall be conducted and sensitized on the issue of manual scavenging.

(2) The State Level Survey Committee and the District Level survey Committee shall carry out adequate campaigns at various levels especially in all such areas where insanitary latrines have been found during the survey of insanitary latrines.

(3) The local authority shall also associate community leaders or non Government Organization working for the welfare of Safai Karamcharis or sanitary workers in identification of manual scavengers.

(4) The local authority shall invite manual scavengers through awareness campaigns to declare themselves at the self declaration centres and have their details verified during a period and at places, which shall be notified by the local authority.

(5) The lists of manual scavengers, if provided by the non Governmental Organisation or any other persons of agency, shall be fully verified to identify manual scavengers.

(6) In case, there is discrepancy between the data of insanitary latrines or the number of manual scavengers thrown up by any person or organisation, the local authority shall order a house-to-house survey of insanitary latrines by the enumerators to know the names of manual scavengers servicing those insanitary latrines.

(7) Local authority shall also make efforts to identify manual scavengers by visiting the habitation of concentration of safai karamcharis, sanitary workers or Manual Scavengers.

(8) Sample checks of the work done by the enumerators would be carried out by overseers designated for the purpose by the local authority, on the basis of random selection to the extent indicated below:—

- (i) 100% check in villages;
- (ii) 100% check in cities and towns having less than 1000 households with insanitary latrines;
- (iii) 50% of the declaration, verified by each enumerator, shall be checked in towns or cities having 1000 to 9999 households with insanitary latrines;
- (iv) 33% of the declaration, verified by each enumerator, shall be checked in towns/cities having 10000 or more households with insanitary latrines;
- (v) In categories (iii) and (iv) if sample check of the work done by any enumerator reveals an error of > 10%, a 100% check of his work shall be carried out by the supervisor.

(9) Any person having objection either to the inclusion or exclusion of any name in the provisional list of manual scavengers in pursuance of the Act, may within a period of fifteen days from the provisional publication, file an objection in the prescribed format specified by the concerned local authority.

(10) The local authorities shall also notify the manner of publication of said list during the survey of manual scavengers carried out under the Act.

(11) The local authority shall get the objections enquired into and hold a meeting, if necessary to finalise the list of manual scavengers in its jurisdiction.

(12) After publication of the final list by the local authority no claim or objection on the list shall be accepted for being included or excluded in the list, provided that the manual scavenger shall be entitled to give self-declaration about his being a manual scavenger.

(13) The District Magistrate shall notify a designated officer not below the rank of Tehsildar or Block Development Officer for inquiring into claims and objection received and giving their findings and the inquiry conducted by the designated authority shall ensure that-

- (i) the claimant or objector is given adequate opportunity to be heard;
- (ii) the claimant or objector is given not less than seven day's notice about the date of summary hearing as provided under sub-rule (15);
- (iii) the claimant or objector shall be allowed to support his claim with documentary evidence, if any, as provided under sub-rule (14);

मध्य प्रदेश राजपत्र

True copy
362

(iv) the claimant or objector shall have the right to be represented by a lawyer, Non Governmental Organization or a friend; and

(v) the claimant or objector shall be given a copy of the order passed by the designated authority as provided under sub-rule(20).

(14) Forms for filing claims and objection under these rules shall be made available to the applicants free of charge on demand at the designated place, as also through the website of the local authority and the claimant or objector may support his claim with documentary evidence if any.

(15) Summary hearing shall be conducted by officers designated by the local authority.

(16) The officer designated to verify the claims may order fresh verification, if necessary.

(17) After summary hearing and such further verification (if ordered), the officer would pass an appropriate order, accepting or rejecting the claim or objection, as the case may be, and a copy of the order would be given to the persons concerned.

(18) After settlement of claims and objections by the designated authority, the local authority shall carry out necessary corrections in the draft list and transmit it to the District Level survey committee for its consideration

(19) The District Level Survey Committee shall cause compilation of lists of manual scavengers received from each local authority, town and prepare a list of the Manual Scavengers for the district which the District Collector will forward to the State Government.

(20) The State Government shall have the lists of manual scavengers received from various districts. Compiled and prepare a consolidated State list of manual scavengers.

(21) Any person working as a manual scavenger, may self declare either during the survey undertaken by the local authority, or any time thereafter, apply to the Chief Executive Officer of the local authority, or to any other officer authorised by him in this behalf, for being identified as a manual scavenger in the prescribed proforma. Format to the application is given at Annexure-II.

(22) There shall be no minimum age limit for identification of manual scavenger, and there shall be no restriction regarding the caste or religion or income or gender for being identified as manual scavenger.

(23) For the purpose of sub-rule(22), a person should have been engaged or employed as manual scavenger at the commencement of the Act or thereafter and should have worked as such continuously for not less than three months.

(24) A provisional list of identified manual scavengers as verified by the Overseers, shall be published by the concerned local authority in local newspaper and displayed in its own office and at such other places as may deemed appropriate.

(25) A copy of the provisional list shall be made available to members of the local authority and the non Governmental Organizations or community leader of Safai Karamcharis or sanitary workers.

(26) While publishing the provisional list, the local authority shall call upon members of the public to file claims and objection vis-a-vis, the list; within a period not less than 15 days in a proforma notified by the local authority.

(27) After the approval of the final list by the District Level Survey Committee, it shall be duly published at the notice boards of concerned offices and the final list shall also be uploaded on the website of the District Administration and the State Government.

//True copy,

363

12. **The identified**—The identified manual scavenger, one from each family, shall be eligible for receiving cash assistance of Rs. 40,000 immediately after identification. The beneficiary shall be allowed to withdraw the amount in monthly instalments of maximum of Rs.7,000.

CHAPTER-IV POWERS OF THE INSPECTOR

13. **Power of the Inspector**.—If an inspector has reason to believe that an offence under the Act as defined under section 5, sub-section(2) of section 6 or 7 of the Act has, or is, or is likely to take place, he shall conduct inspection, investigation or enquiry:-

(1) If the offence pertains to the construction, maintenance or use of an insanitary latrine, the inspector shall report to the local authority, which shall thereafter take action as per the provisions of the Act.

(2) If the offence pertains to the employment of manual scavengers, the inspector shall send a

(3) The local authority shall take steps to include the name of a manual scavenger found to be employed in the final list of manual scavengers, whether during survey or any time thereafter, and once the name of a manual scavenger is added to the final list, the manual scavengers shall be rehabilitated under the provisions of the Act.

(4) If it appears to the inspector that hazardous cleaning of sewer or septic tanks is being resorted to, the inspector shall order to stop such hazardous cleaning forthwith and shall report the matter to the local authority.

(5) The inspector may examine any structure, site, place or premises within his jurisdiction, when there are reasons to believe that any such premises is being used or has been used or about to be used for hazardous cleaning of sewer or septic tank.

(6) The inspector may take on the spot or otherwise such evidence of any person which he may consider necessary for the purpose of any examination or enquiry connected with insanitary latrines or hazardous cleaning of sewer or septic tank:

provided that such person shall not be compelled to answer any question or give any such evidence tending to incriminate him.

(7) The inspector may take or caused to be taken any photograph, video clip, sample, record or make any sketch by using any device including electronic device as he may consider necessary for the purpose of any examination or enquiry, under these rules.

(8) On finding that a local authority, person or agency is engaging in or employing a person in hazardous cleaning, the inspector shall instruct such authority, person or agency to stop such undertaking of cleaning immediately and shall serve a notice in writing in this regard in Form annexed as annexure-III to these rules.

CHAPTER-V

STATE MONITORING COMMITTEE

14. **The state Monitoring Committee**—(1) The state Monitoring committee shall meet atleast once in six months on such dates and times as may be prescribed by the Chairperson.

(2) The meeting shall normally be held at the State Headquarters.

(3) Where the Committee finds it necessary to hold the meeting at any other place, for the reasons to be recorded in writing, such meeting may be held at other places, within the State.

(4) Member-Secretary shall cause a notice of minimum ten days issued to all the members of the committee and also send the list of business to be considered during the meeting.

364 //True copy//

(5) No business, which is not included in the list of business shall be considered, without the premission of the Chairperson.

(6) The Chairperson shall preside over each meeting at which he is present and in his absence, members may elect the senior most member present to be Chairperson to preside over the meeting

(7) No business shall be transacted at a meeting unless atleast one third of the total members of the Committee are present:

Provided that if at any meeting, less than one third of the member are present, the Chairperson may adjourn the meeting to a date not less than seven days from the date of the meeting, informing the members present and sending registered notice to other members.

(8) Business at the adjourned meeting shall be disposed irrespective of the quoram.

(9) The proceeding of each meeting shall be circulated to all members present and shall be read out and confirmed at the next meeting of the committee, and shall be signed by the Chairperson.

(10) The minutes shall be recorded in a minute book which shall be kept as a permanent record.

(11) A copy of the minntes shall he endorsed to the Central Government for the information of the Central Monitoring Committee.

Annexure-I
(see rule 7)

First Aid Facilities.—

1. At every work place there shall be provided and maintained, so as to be easily accessible during working hours, not less than one first-aid-box for 150 employees.

2. The first-aid box shall be distinctly marked with a red cross on white back ground and shall contain the following equipments, namely:-

(A) For work places in which the number of employees employed does not exceed 50, each first-aid box shall contain the following equipments :-

- (i) 6 small sterilised dressings;
- (ii) 3 medium size sterilised dressings;
- (iii) 3 large size sterilised dressings;
- (iv) 3 large size sterilised burn dressings;
- (v) 1(30 ml.) bottle containing a two percent alcoholic solution iodine;
- (vi) bottle (30ml) containing salvolatile having the dose and mode of administration indicated on the label;
- (vii) 1snakebite lancet;
- (ix) 1 pair scissors;
- (x) 1 copy of the first-aid leaflet issued by the Director General Factory, Advice Service and Labour Institutes, Government of India;

//True copy//

365

- (xi) 1 bottle containng 100 tablets (each of 5 gms.) of aspirin;
- (xii) Ointment for burns;
- (xiii) A bottle of suitable surgical autiseptic solution.

(B) For work places in which the number of employee exceeds 50, each first-aid box shall contain the following equipment:-

- (i) 12 small sterilised dressings;
- (ii) 6 medium size sterilised dressings;
- (lii) 6 large size sterilised dressings;
- (iv) 6 large size sterilized burn dressings;
- (v) 6 packets (IS GMS) steriized cotton wool;
- (vi) 1 bottle (60ml.) containing a two percent alchooic solution iodine;
- (vii) 1 bottle (60ml.) containing salvolatile having the dose and mode of administration indicated on the lable;
- (viii) 1 roll of adhesive plaster;
- (ix) 1 suake bite lancet;
- (x) 1 bottle (30gms) of potassium permanganate crystals;
- (xi) 1 pair scissors;
- (xii) 1 copy of the first-aid leaflet issued by the Director General Factory Advise Service and Labour Institutes of the Government of India;
- (xiii) A bottle containing 100 tablets (each of 5 gms.) of aspirin;
- (xiv) Ointment for burns;
- (xv) A bottle of suitable surgical antiseptic solution.

- (C) Adequate arrangements shall be made for immediate recoument of the equipment, when necessary.
- (D) The first-aid box shall be kept in charge of a responsible person who shall always be readily available during the working hours of the work place.
- (E) A person in charge of the first-aid box shall be a person trained in first-aid treatment, in the work places where the nnumber of employed is 150 or more.
- (F) In the work plaees where the number of employees in 500 or more and hospital facilities are not available within easy distance from the work place, first- aid posts shall be established aud run
- (G) Where work piaces are situated in places which are not towns or cities, a suitable motor transport shall be kept readily available to -carry injured person or person suddenly taken ill to the nearest hospital.
- (H) The first-aid box shall not contain any other equipment or substance as mentioned in paragraph 1. and 2.

ANNEXURE-II

[See rule 11 (2)]
Self Declaration Form

Identification of the persons engaged in manual scavenging

[Empty box for office use]

(Office use)

- Name of the State
- District
- MunicipalityTown Ward
- Panchayat Village

Photo of the person engaged in manual scavenging

Family Photo of the person engaged in manual scavenging
(Picture post card size photograph "6x4")

1. Name of the of the persons engaged in manual scavenging
2. Name of Father/Mother/Spouse
3. Age
4. Sex : Male Female
5. Education Status: (put a ✓ mark in the appropriate box)
 - (i) (a) literate (b) not literate
 - (ii) If litrate label of education :
 - (a) Studies : class Class 6-10 Class 11-12 Class above 12
6. Ocenpation :—
 - (i) Carrying/disposing/cleanng of human excreta manually from insanitary latrine
 - (ii) Cleaning untreated human excrete manually from (a) open drain
 - (b) Railway Track

TRUE COPY

367

367

(Note : please give detailed description on the individual Insanitary Latrine cleaned by the person engaged in manual scavenging. In case you need to write extra information kindly photocopy this page and attach with the survey form).

2. Details of Community Insanitary Latrine (CIL)

S. No.	Name of the owner (Organisation/Agency) of community Insanitary Latrine	Location of the		Monthly salary/wages of the Manual Scavenger (Rs.)	
		Dry latrine	Latrine from which excreta is being flushed into open drain	In cash	In food grains etc
(1)	(2)	(3)	(4)	(5)	(6)

3. Details of open drains (OD) Railway Tracks/other spaces :

S. No.	Location of Open Drains/Railway tracks/other spaces in which excreta from the insanitary latrines is being flushed	Salary/wages of the Manual Scavenger (Rs.)	
		In cash (Rs.)	In kind (Rs.)
(1)	(2)	(3)	(4)

(Note : If the number of involved manual scavengers in open drain is more than one then please fill up a separate form for each of the person engaged in manual scavenging).

ANNEXURE-III

Office of the Inspector under section 20 of the Prohibition of Employment as Manual Scavengers and their Rehabilitation Act, 2013 (Area nante).

NOTICE

{under rule 13(8) of the Prohibition of Employment as Manual Scavengers and their Rehabilitation Rules, 2014 }

Ref.....

date

To,

.....
.....
.....

Subject : Notice under the Prohibition of Employment as Manual Scavengers and their Rehabilitation Act, 2013 (hereinafter referred the Act), and the Prohibition of Employment as Manual Scavengers and their Rehabilitation Rules, 2014 (hereinafter referred the Rules) : Hazardous cleaning of sewers and septic tanks.

370

True copy//

Whereas, Section 7 of the Act provides that no person, local authority or any agency shall, from such date as the State Government may notify, which shall not be later than one year from the date of commencement of this Act, engage or employ, either directly or indirectly, any person for hazardous cleaning of a sewer or a septic tank;

and whereas, the (Name of State) Government has notified the date of enforcement of the provision of Section 7 of the Act as (Date of effect) ;

and whereas, cleaning of sewers and septic tanks is regulated under the provision of rules 3 to of the Rules;

and whereas, you have been noticed to have violated the provision of section 7, read with section 2

(1) (d) of the said Act and the rule made thereunder, as per the following details:—

(i) Place of violation

(ii) Date of violation

(iii) violation details :—

2. You are requested to show cause as to why action you under section of the Act be not invited. You are requested to submit your clarification in writing by (date) or appear in person in my office on at

3. In case you fail to submit the necessary clarification or you or your representative fails to appear on the specified day and time, it shall be deemed that you have nothing to say in the matter and the undersigned shall be free to take action in accordance with the provision of the Act and the Rules.

Name and designation of the Inspector

Place:

Date:

मध्यप्रदेश के राज्यपाल के नाम से तथा आदेशानुसार,

अशोक शाह, प्रमुख सचिव.

True Copy

संघीय लोकसेवा आयोग

(अध्याय)

प्रधिकार से प्रकाशित

क्रमांक 399]

भारत, भारत, दिनांक 2 फरवरी 2014—पृष्ठ 11, भाग 1936

अनुसूचित जाति कल्याण विभाग

भारत, भारत, भारत

भारत, दिनांक 2 फरवरी 2014

क्र. एक 12-32-2013-4-पृष्ठ-4.—राज्य से सेवा उदात्त वाले कर्मियों के नियोजन का आदेश और उक्त प्रस्ताव आदेश, अधिनियम, 2013 (2013 का 25) की धारा 21 द्वारा प्रदात शक्ति की प्रयोग में लाई हुई, राज्य सरकार, पंजाब, जप खण्ड दण्डाधिकारियों की उक्त अधिनियम के अर्थात अध्याय का विचारण करने के लिए सांख्यिक दण्डाधिकारियों, प्रथम श्रेणी की शक्तियां प्रदान करने के लिए दण्ड प्रक्रिया संहिता, 1973 (1974 का 1) के प्रयोजन के लिए उक्त सांख्यिक दण्डाधिकारियों प्रथम श्रेणी सभ्यता जाण्ये।

No. F-12-32-2013-4-XXV-4.—In exercise of the powers conferred by sub-section (1) Section 21 of the Prohibition of Employment as Manual Scavengers and their Rehabilitation Act, 2013 (No. 25 of 2013), the State Government, hereby, confer the powers of a Judicial Magistrate of the First Class for the trial of offences under the said Act to the Sub-Divisional Magistrate and he shall be deemed for the purpose of the Code of Criminal Procedure, 1973 (No. 1 of 1974) to be a Judicial Magistrate of First Class.

राज्य के राजधानी के नाम से देना आदेशित, संशोधित, अथवा संशोधित, संशोधित.

Handwritten signature or stamp



के अधिकारिता www.governmpunjab.gov.in से भी प्राप्त की जा सकती है.

इसे वेबसाइट www.govtpressmp.nic.in
से भी डाउन लोड किया जा सकता है.



मध्यप्रदेश राजपत्र

(असाधारण)
प्राधिकार से प्रकाशित

क्रमांक 398]

भोपाल, मंगलवार, दिनांक 2 सितम्बर 2014—भाद्र 11, शक 1936

अनुसूचित जाति कल्याण विभाग
मंत्रालय, वल्लभ भवन, भोपाल
भोपाल, दिनांक 2 सितम्बर 2014

क्र. एफ 12-32-2013-4-पच्चीस-3.—हाथ से मैला उठाने वाले कर्मियों के नियोजन का प्रतिषेध और उनका पुनर्वास अधिनियम, 2013 (2013 का 25) की धारा 18 द्वारा प्रदत्त शक्तियों को प्रयोग में लाते हुए, राज्य सरकार, एतद्वारा, नगरपालिका निगमों, नगरपालिकाओं और नगर पंचायतों के समस्त स्वास्थ्य अधिकारियों को नगरीय निकाय की उनकी अधिकारिता के भीतर इस अधिनियम के प्रयोजन के लिए निरीक्षक के रूप में नियुक्त करती है और जनपद पंचायतों के मुख्य कार्यपालन अधिकारियों को भी इस अधिनियम की धारा 20 की उपधारा (2) में वर्णित प्रयोजनों के लिए निरीक्षक के रूप में नियुक्त करती है.

No. F-12-32-2013-4-XXV-3.—In exercise of the powers conferred by sub-section (1) Section 20 of the Prohibition of Employment as Manual Scavengers and their Rehabilitation Act, 2013 (No. 25 of 2013), the State Government, hereby, Appoints all Health Officers of Municipal Corporations, Nagar Palika and Nagar Panchayats as Inspector for the purpose of this Act, within their jurisdiction of urban body and also appoints Chief Executive Officer of Janpad Panchayats as Inspector for the purpose of this Act mentioned in sub-section (2) of Section 20.

मध्यप्रदेश के राज्यपाल के नाम से तथा आदेशानुसार,
अजय सिंह मंगलवार, उपसचिव.

795

नियंत्रक, शासकीय मुद्रण तथा लेखन सामग्री, मध्यप्रदेश द्वारा शासकीय केन्द्रीय मुद्रणालय, भोपाल से मुद्रित तथा प्रकाशित—2014.

True copy//
373

374

True copy

राज्यपाल के नाम से तथा आदेशानुसार,
अन्य सिंह गिजारा, उपसचिव,

No. P-12-32-2013-4-XXV-2.—In exercise of the powers conferred by Section 18 of the Prohibition of Employment as Manual Scavengers and their Rehabilitation Act, 2013 (No. 25 of 2013), the State Government, hereby, confer such powers and impose such duties on local authority and District Magistrate as may be necessary to ensure that the provisions of this Act are properly carried out.

क. एक 12-32-2013-4-पञ्जीम-2.—राज्य से श्रम से निवृत्त होने वाले कर्मियों के निरीक्षण का प्रविष्टि और उनका पुनर्वासि अधिनियम, 2013 (2013 का 25) की धारा 18 द्वारा प्रदत्त शक्तियों को प्रयोग में लाने हेतु, राज्य सरकार, एतद्वारा, स्थायी प्रतिकारियों और निरीक्षण अधिनियम की ऐसी शक्तियों प्रदान करती है और उन पर ऐसे कर्तव्य अधिरोपित करती है जो इस अधिनियम के उपबंधों का समुचित निष्पादन सुनिश्चित करने के लिये आवश्यक हों।

अनुसूचित जाति कल्याण विभाग
मजालिय, बरलस भवन, भीपाल
भीपाल, दिनांक 2 सितम्बर 2014

कमर्क 397] भीपाल, मजालिय, दिनांक 2 सितम्बर 2014—पार 11, शक 1936

संस्कृत प्रकाशक (असाधारण)



इसे वेबसाइट www.govtpressm.p.nic.in से भी डाउनलोड किया जा सकता है।

वेबसाइट www.govtpressmp.nic.in
से भी डाउन लोड किया जा सकता है.



मध्यप्रदेश राजपत्र

(असाधारण)

प्राधिकार से प्रकाशित

क्रमांक 431]

भोपाल, सोमवार, दिनांक 15 सितम्बर 2014—भाद्र 24, शक 1936

अनुसूचित जाति कल्याण विभाग
मंत्रालय, वल्लभ भवन, भोपाल
भोपाल, दिनांक 15 सितम्बर 2014

क्र. एफ 12-32-2013-4-पच्चीस-5.—हाथ से मैला उठाने वाले कर्मियों के नियोजन का प्रतिबंध और उनका पुनर्वास अधिनियम, 2013 की धारा 32 (1) द्वारा प्रदत्त शक्तियों को प्रयोग में लाते हुए, राज्य सरकार, एतद्द्वारा, राज्य अनुसूचित जाति आयोग, मध्यप्रदेश को इस अधिनियम की धारा 31/1 के तहत उल्लेखित कार्य करने हेतु शक्ति प्रदत्त करती है.

No. F-12-32-2013-4-XXV-4.—In exercise of the powers conferred by sub-section (1) of Section 32 of the Prohibition of Employment as Manual Scavengers and their Rehabilitation Act, 2013 (No. 25 of 2013), the State Government, hereby, designate Madhya Pradesh State Scheduled Caste Commission as an appropriate authority, within the State, to perform mutatis mutandis, the functions specified in sub-section (1) of 31.

मध्यप्रदेश के राज्यपाल के नाम से तथा आदेशानुसार,
अजय सिंह गंगवार, उपसचिव.

861

नियंत्रक, शासकीय मुद्रण तथा लेखन सामग्री, मध्यप्रदेश द्वारा शासकीय केन्द्रीय मुद्रणालय, भोपाल से मुद्रित तथा प्रकाशित—2014.

//True copy//

375

इसे वेबसाईट www.govtpressmp.nic.in
से भी डाउन लोड किया जा सकता है.



मध्यप्रदेश राजपत्र

(असाधारण)

प्राधिकार से प्रकाशित

क्रमांक 396]

भोपाल, मंगलवार, दिनांक 2 सितम्बर 2014—भाद्र 11, शक 1936

अनुसूचित जाति कल्याण विभाग
मंत्रालय, वल्लभ भवन, भोपाल

भोपाल, दिनांक 2 सितम्बर 2014

क्र. एफ 12-32-2013-4-पच्चीस-1.—हाथ से मैला उठाने वाले कर्मियों के नियोजन का प्रतिषेध और उनका पुनर्वास अधिनियम, 2013 (2013 का 25) की धारा 7 द्वारा प्रदत्त शक्तियों को प्रयोग में लाते हुए, राज्य सरकार, एतद्द्वारा, व्यक्तियों को प्रत्यक्ष अथवा अप्रत्यक्ष रूप से खतरनाक तरीके से सैप्टिक टैंक और नालों की सफाई के काम में नियोजित करने अथवा काम में लगाने का प्रतिषेध करती है.

No. F-12-32-2013-4-XXV-1.—In exercise of the powers conferred by Section 7 of the Prohibition of Employment as Manual Scavengers and their Rehabilitation Act, 2013 (No. 25 of 2013), the State Government, hereby, prohibits the engagement or employment of the persons either directly or indirectly of hazardous cleaning of sewers and septic tanks.

मध्यप्रदेश के राज्यपाल के नाम से तथा आदेशानुसार,
अजय सिंह गंगवार, उपसचिव.

मध्यप्रदेश

1. अतिरिक्त अधिकारी
अध्यक्ष
2. वरिष्ठ अधिकारी के अध्यक्ष और मुख्य कार्यपालन अधिकारी
अध्यक्ष
3. अतिरिक्त अधिकारी, पुलिस
अध्यक्ष
4. मुख्य कार्यपालन अधिकारी, नगर प्रशासन
अध्यक्ष
5. कलेक्टर जी (परि कोंटि एच)
अध्यक्ष
6. उपखण्ड में स्थित सेवा को अधिकारी
अध्यक्ष
7. एच. सी. डी. उदाहरण के अधिकारी के प्रतिबंध और प्रशासन के लिए कार्य करने वाले सेवा से संबंधित अधिकारी को सामाजिक कार्यकर्ता, अथवा कलेक्टर द्वारा नामित किए जाने वाले अधिकारी सदस्य से संबंधित प्रतिबंध विषय से 1 महिला है।

क. एक 12-32-2013-पन्नी-4-राज्य शासन प्रादेशिक सेवा से सेवा उदाहरण के अधिकारी के नियोजन का प्रतिबंध और उदाहरण प्रदान आदेशों का अर्थ है, उपखण्ड क्षेत्रीय सरकारें समिति गठित करने की प्रतीति है, उपखण्ड क्षेत्रीय सरकारें समिति का गठन विनियमन सेवकों के साथ किया जावे:-

श्रीमान, दिनांक 29 फरवरी 2014

अतिरिक्त जॉर्ज कल्याण विभाग
श्रीमान, वरिष्ठ अधिकारी, श्रीमान

श्रीमान, श्रीमान, दिनांक 29 फरवरी 2014-आदेश 7, एक 1936 [कॉपी 461]

प्रशासन से प्रकाशित
(अप्रकाशित)
प्रशासन से प्रकाशित



कई वेबसाइटें www.govtexpress.com हैं।
ती भी उदाहरण कोड किया जा सकता है।

True copy

भारतीय प्रत्यक्ष निवेश अधिनियम, 2014 के प्रावधानों के अन्तर्गत, भारत में प्रतिष्ठित तथा कानून-2014

- 1. अर्थिक और इसके अन्तर्गत अन्य प्रावधानों का उचित विधि से पालन सुनिश्चित करने के लिए समस्त देना या कार्यवाही प्रस्तावित करना.
 - 2. इस से पैदा होने वाली की आर्थिक और सामाजिक प्रभावों को देख-रेख करना.
 - 3. प्रभावों के विषय पर चर्चा channelize करने की दृष्टि से सभी संबंधित एजेंसियों के कार्यों का समन्वय करना.
 - 4. इस अधिनियम के अन्तर्गत अर्थिक, न्याय और अधिनियम का अनुपालन करना.
 - 3. समिति अधिनियम के विभाजन का पालन प्रतिबद्ध नियमित रूप से बिना समकालीन समिति को प्रस्तुत करना सुनिश्चित करेगी.
2. इस समिति के निम्न कार्य होंगे:—

भारत में प्रतिष्ठित तथा कानून-2014 के प्रावधानों के अन्तर्गत, भारत में प्रतिष्ठित तथा कानून-2014

- 8. अनुपालन प्रति कम्पानि विभाग का उपलब्ध आधिकारी
- 9. विभाग और अधिकारों के उपलब्ध सभी आधिकारी जो

True copy

925

- 1. मुख्यमंत्री अथवा नामांकित मंत्री
- 2. अतिरिक्त जाति कल्याण मंत्री
- 3. अध्यक्ष, राज्य अतिरिक्त जाति आयोग
- 4. राष्ट्रीय अतिरिक्त जाति आयोग का प्रतिनिधि
- 5. अतिरिक्त जाति वर्ग के राज्य विधान सभा के सदस्य
- 6. प्रतिष्ठित पदाधिकारी
- 7. मुख्य सचिव/सचिव, गृह
- 8. मुख्य सचिव/सचिव, स्वास्थ्य एवं प्रौद्योगिकी विभाग
- 9. मुख्य सचिव/सचिव, राष्ट्रीय प्रशासन एवं प्रशासन विभाग
- 10. आयुक्त, नगर निगम (कोई भी एक)
- 11. मुख्य कार्यपालन अधिकारी, बिना पंचायत (कोई भी एक)
- 12. केंद्रनियंत्रित बोर्ड की अधिकारी

क्र. एक 12-32-2013-पच्चीस-4.—राज्य शासन एतद्वारा द्वितीय संशोधन अधिनियम, 2013 की धारा 26 में प्रदत्त शक्तियों का उपयोग करते हुए राज्य विधान सभा के सदस्यों का गठन विधानसभा संरचना के साथ करा है:-

धीपल, दिनांक 29 सितम्बर 2014

अतिरिक्त जाति कल्याण विभाग
धीपल, बरखण भवन, धीपल

धीपल, धीपल, दिनांक 29 सितम्बर 2014—आरिचन 7, एक 1936

क्रमांक 463]

राज्य अतिरिक्त जाति कल्याण विभाग
(असाधारण)
धीपल से प्रकाशित



ई वेबसाइट www.govtexpressmp.in से भी सूचना दी जा सकती है.

सदस्य

सदस्य

13. तले विभाग का एक प्रतिनिधि

14. कोय से पैदा उठाये के कर्मियों के प्रतिबन्ध और प्रस्तावों के लिए कार्य करने वाले मालिक से संबंधित अधिकतम चार सामाजिक

कार्यकारी, अथवा

राज्य में विद्यमान सफाईकर्मी संघों से संबंधित प्रतिनिधि

विषय से 2 महिना हैं।

15. राज्य प्रमुख, राज्य स्तरीय वेकर्स सभिति

सदस्य

16. प्रमुख सचिव/सचिव अग्रसरचित्त जॉर्जि कल्याण विभाग

सदस्य सचिव

17. अन्य विभागों और अधिकरण जो इस अधिनियम के पारतन से महत्वपूर्ण पहिना निर्देश कर सकते हैं।

सदस्य

2. इस सभिति के निम्न कार्य होंगे:—

1.

अधिनियम और इसके तहत बनावे गये नियम के प्रावधानों का जबाब विधि से पालन सुनिश्चित करने के लिए सहाय देना या कार्यवाही प्रस्तावित करना।

2.

सभी संबंधित एजेंसियों के मध्य सम्बन्ध करना।

3.

इस अधिनियम से संबंधित उत्पन्न परिस्थितियों पर कार्य करना तथा निर्देश देना।

3. सभिति अधिनियम के क्रियान्वयन का पालन प्रतिबन्ध नियम रूप से भारत सरकार को प्रस्तुत करना सुनिश्चित करेगी।

मध्यदेशी के राज्यपाल के नाम से तथा आदेशानुसार,

सचिव राज, अथवा सचिव

380
मध्यदेशी न्याय

True copy

381

919

1. राज्य स्तर पर सर्वेक्षण की मॉनिटर एवं सर्वेक्षण करना.

2.

2. इस समिति के निम्न कार्य होंगे:-

1. अतिरिक्त मुख्य सचिव अथवा प्रमुख सचिव
2. प्रमुख सचिव, राष्ट्रीय कल्याण एवं विकास विभाग
3. संचालक, आर्थिक, योजना एवं सांख्यिकी
4. संचालक, राज्य योजना निर्देशालय, मध्यप्रदेश
5. रेल प्राधिकरण का एक प्रतिनिधि
6. राज्य से पैला उठाने के कर्मियों के प्रतिबंध और पुनर्वास के लिए कार्य करने वाले गैर सरकारी संगठन के दो सदस्य
7. समुदाय के दो प्रतिनिधि (एक महिला) नामनिर्दिष्ट
8. आयुक्त, अनुसूचित जाति विकास

सदस्य सचिव

सदस्य

सदस्य

सदस्य

सदस्य

सदस्य

सदस्य

अध्यक्ष

क्र. एक 12-32-2013-पञ्जीस-4-राज्य शासन, एटाद्वारा, राज्य से पैला उठाने वाले कर्मियों के नियोजन का प्रतिबंध और उनका पुनर्वास अधिनियम, 2013 की धारा 11 (2) एवं 14 में प्रदत्त शक्तियों का उपयोग करते हुए, राज्य से पैला उठाने वाले कर्मियों के सर्वेक्षण के अनुश्रवण हेतु 'राज्य सर्वेक्षण समिति' का गठन निम्नानुसार संरचना के साथ कराया है:-

भोपाल, दिनांक 29 सितम्बर 2014

अनुसूचित जाति कल्याण विभाग
संचालक, वल्लभ भवन, भोपाल

क्रमांक 460] भोपाल, सोमवार, दिनांक 29 सितम्बर 2014-आश्विन 7, शक 1936

मध्यप्रदेश राजपत्र

(असाधारण)

प्राधिकार से प्रकाशित



इसे वेबसाइट www.govpressmp.nic.in से भी डाउन लोड किया जा सकता है.

382

True copy

सचिव, अवर सचिव,

मध्य प्रदेश के राज्यपाल के नाम से तथा आदेशानुसार,

3. सर्वेक्षण के संबंध में स्थानीय समाचार पत्रों द्वारा हलवाई के माध्यम से प्रचार की व्यवस्था करना.
4. अपने अधिकारिता के अधीन अधिहित स्थानों पर अतिरिक्त सर्वेक्षण सामग्री का वितरण करना.
5. राज्य से सभी शहर, नगर और ग्रामों के लिए हवा से फैला उड़ाने वाले कर्मियों की अंतिम सूची को अनुमोदित करना.
6. राज्य में फैला उड़ाने वाले कर्मियों की अंतिम समीकृत सूची प्रकाशित करना.

इसे वेबसाईट www.govpressmp.nic.in
से भी डाउन लोड किया जा सकता है.



मध्यप्रदेश राजपत्र

(असाधारण)
प्राधिकार से प्रकाशित

क्रमांक 400]

भोपाल, मंगलवार, दिनांक 2 सितम्बर 2014—भाद्र 11, शक 1936

अनुसूचित जाति कल्याण विभाग
मंत्रालय, वल्लभ भवन, भोपाल
भोपाल, दिनांक 2 सितम्बर 2014

क्र. एफ 12-32-2013-4-पच्चीस-5.—तथा से मैला उठाने वाले कर्मियों के नियोजन का प्रतिषेध और उनका पुनर्वास अधिनियम, 2013 (2013 का 25) की धारा 4 की उपधारा (2) द्वारा प्रदत्त शक्तियों को प्रयोग में लाते हुए, राज्य सरकार, एतद्द्वारा, समस्त नगरपालिकाओं तथा नगरपालिका निगमों को उनकी अधिकारिता के भीतर खुले में शौच की प्रथा को दूर करने लिए 06-12-2015 तक पर्याप्त संख्या में सामुदायिक स्वच्छ शौचालयों का निर्माण करने के लिए सशक्त करती है.

No. F-12-32-2013-4-XXV-5.—In exercise of the powers conferred by sub-section (2) of Section 4 of the Prohibition of Employment as Manual Scavengers and their Rehabilitation Act, 2013 (No. 25 of 2013), the State Government, hereby, empowers all Municipalities and all Municipal Corporations to construct adequate number of sanitary community latrines, by 06-12-2015 to eliminate the practice of open defecation in their jurisdiction.

मध्यप्रदेश के राज्यपाल के नाम से तथा आदेशानुसार,
अजय सिंह मंगवार, उपसचिव.

799

इसे वेबसाईट www.govtpressmp.nic.in से भी डाउन लोड किया जा सकता है.



मध्यप्रदेश राजपत्र

(असाधारण)

प्राधिकार से प्रकाशित

क्रमांक 530]

भोपाल, शुक्रवार, दिनांक 21 नवम्बर 2014—कार्तिक 30, शक 1936

अनुसूचित जाति कल्याण विभाग

मंत्रालय, वल्लभ भवन, भोपाल

संशोधन

भोपाल, दिनांक 20 नवम्बर 2014

क्र. एफ 12-32-2013-पच्चीस-4.—हाथ से मैला उठाने वाले कर्मियों के नियोजन का प्रतिषेध और उनका पुनर्वास अधिनियम, 2013 के तहत जारी अधिसूचना क्रमांक 400, दिनांक 2 सितम्बर, 2014 में पर्याप्त संख्या में सामुदायिक स्वच्छ शौचालयों के निर्माण हेतु अधिसूचित समयसीमा '06-12-2015' के स्थान पर दि. '06-12-2016' पढ़ा जाये.

AMENDMENT

NO. F 12-32-2013-XXV-4.—The timeframe for constructing adequate number of community sanitary latrines notified in the Gazette Notification No. 400 dated 2nd September, 2014 issued under The Prohibition of the Employment as Manual Scavengers and Their Rehabilitation Act, 2013 should read '06-12-2016' instead of '06-12-2015'.

मध्यप्रदेश के राज्यपाल के नाम से तथा आदेशानुसार,
अशोक शाह, प्रमुख सचिव.

True Copy

1059

इसे वेबसाईट www.govtpressmp.nic.in
से भी डाउन लोड किया जा सकता है.



मध्यप्रदेश राजपत्र

(असाधारण)
प्राधिकार से प्रकाशित

क्रमांक 462]

भोपाल, सोमवार, दिनांक 29 सितम्बर 2014—आश्विन 7, शक 1936

अनुसूचित जाति कल्याण विभाग
मंत्रालय, वल्लभ भवन, भोपाल
भोपाल, दिनांक 29 सितम्बर 2014

क्र. एक 12-32-2013-पच्चीस-4.—राज्य शासन एतद्वारा हाथ से मैला उठाने वाले कर्मियों के नियोजन का प्रतिषेध और उनका पुनर्वास अधिनियम, 2013 की धारा 24 (1) में प्रदत्त शक्तियों का उपयोग करते हुए, जिला सर्वका समिति का गठन निम्नानुसार संरचना के साथ करता है:—

- | | | |
|----|------------------------------------------------------------------------------------------------------------------------------------------------------------------------------------------------------------------------------------------|---------|
| 1. | जिला कलेक्टर | अध्यक्ष |
| 2. | जिले से चयनित समस्त अनुसूचित जाति के विधान सभा सदस्य | सदस्य |
| 3. | जिला पुलिस अधीक्षक | सदस्य |
| 4. | मुख्य कार्यपालन अधिकारी, जिला पंचायत | सदस्य |
| 5. | आयुक्त, नगर निगम अथवा मुख्य नगरपालिका अधिकारी, नगरपालिका | सदस्य |
| 6. | कैबिनेट बोर्ड (यदि कोई हो) | सदस्य |
| 7. | रेल्वे का प्रतिनिधि | सदस्य |
| 8. | हाथ से मैला उठाने के कर्मियों के प्रतिबंध और पुनर्वास के लिए कार्य करने वाले संगठन से संबंधित अधिकतम चार सामाजिक कार्यकर्ता, अथवा कलेक्टर द्वारा नामांकित जिले में निवासरत् सफाईकर्मी समुदाय से संबंधित प्रतिनिधि जिनमें से 2 महिला हों. | सदस्य |

923

TRUE COPY!!

38-5

True copy

सावित्र राव, अवर सचिव,

मध्यप्रदेश के राज्यपाल के नाम से तथा आदेशानुसार,

सुनिश्चित करेंगे।

3. संपत्ति अधिनियम के क्रिया-व्ययन का पालन प्रतिबन्धन नियमित रूप से अनुसूचित जाति कल्याण विभाग को प्रस्तुत करना

4. इस अधिनियम के तहत अपराधी के पंजीकरण, जांच और अभियोजन का अनुश्रवण करना.

3. पुनर्वास के लिये पर्याप्त चैनल channelize करने की दृष्टि से सभी संबंधित एजेंसियों के कार्यों का समन्वय करना.

2. दाय से पैसा होने वाली की आर्थिक और सामाजिक पुनर्वास की देख-रेख करना.

सलाह देना या कार्यवाही प्रस्तावित करना.

1. अधिनियम और इसके तहत बनाये गये नियम के प्रावधानों का उचित विधि से पालन सुनिश्चित करने के लिए

2. इस संपत्ति के निम्न कार्य होंगे:-

किया जायेगा.

क्रमांक 2 में यदि जिले में अनुसूचित जाति वर्ग के विद्यमान सभी सदस्य निर्वाचित नहीं हुए हों ऐसी दशा में राज्य शासन द्वारा नामांकन

10. अनुसूचित जाति कल्याण विभाग का जिला अधिकारी सदस्य सचिव

साथ संस्थान का एक प्रतिनिधि.

9. जिला कलेक्टर द्वारा नामांकित जिले की विरीय और सदस्य

387

True copy

Cont.....

2.4 स्वीच एवं सैटिक टैंक की साफ सफाई हेतु शहरी एवं आवासन मंत्रालय द्वारा जारी परामर्श दस्तावेज -CPHEEO Manual, Standard Operating Procedures for Cleaning of Sewer and Septic tanks released by MoHUA, Preventing of employment as manual scavengers and their rehabilitation act (PEMSRA, 2013) आदि समय समय पर शासन/नगरीय प्रशासन विभाग/स्वावलोकन, नगरीय प्रशासन एवं विकास द्वारा समय समय पर जारी किए गए प्रबंधन लागू होंगे।

2.2 निकाय अपने क्षेत्र के 75 किलो मीटर के दायरे में डकॉर्ड की सेवाएं प्रदान करेंगी।
 2.3 स्वीच लाइन एवं सैटिक टैंक के अंदर साफ सफाई हेतु किसी भी स्थिति में मानव बल का स्वीच लाइन/सैटिक टैंक में प्रवेश प्रतिबंधित होगा। किन्तु व्यापक जनहित हेतु सभ्यगीय कार्यवाहकन यंत्रों की लिखित अनुमति उपरान्त विशेष परिस्थिति में ही स्वीच लाइन में प्रवेश की अनुमति नियमानुसार शर्तों के प्रावधान उपरान्त ही प्रदान की जाएगी।

2.1 डकॉर्ड निकाय में स्थित सभी स्वीच लाइन एवं सैटिक टैंक की साफ सफाई हेतु उपलब्ध आधुनिक/नियम/दिशा निर्देश अनुसार कार्य संपादित करेंगे।

2. उपरोक्तानुसार गठित डकॉर्ड के कर्तव्य निम्नानुसार होंगे :-

डकॉर्ड के अन्वय	डकॉर्ड के अन्वय	डकॉर्ड के अन्वय
निकाय का प्रकार	नगर पालिका निगम	निकाय के वरिष्ठ अधिकारी, स्वास्थ्य विभाग के प्रभारी, आधिकारी तथा स्वास्थ्य आधिकारी, डकॉर्ड दस्तावेज आदि
डकॉर्ड के अन्वय	नगर पालिका निगम	निकाय के वरिष्ठ अधिकारी, स्वास्थ्य विभाग के प्रभारी, आधिकारी तथा स्वास्थ्य आधिकारी, डकॉर्ड दस्तावेज आदि
डकॉर्ड के अन्वय	नगर पालिका निगम	निकाय के वरिष्ठ अधिकारी, स्वास्थ्य विभाग के प्रभारी, आधिकारी, डकॉर्ड दस्तावेज आदि
डकॉर्ड के अन्वय	नगर पालिका निगम	निकाय के वरिष्ठ अधिकारी, स्वास्थ्य विभाग के प्रभारी, आधिकारी, डकॉर्ड दस्तावेज आदि

एतद द्वारा स्वीच, सैटिक टैंक आदि संरचनाओं में आपात स्थिति में मानव बल/गैर यांत्रिक द्वारा साफ सफाई के प्रभावी नियंत्रण एवं नियमानुसार प्रबंधन हेतु राज्य के समस्त नगरीय निकायों में निम्न संरचना अनुसार साफ सफाई हेतु आपातकालीन प्रतिक्रिया डकॉर्ड (Emergency Response sanitation Unit, ERSU) गठित करता है :-

क्र./स्व.मा.नि./2020/2147
 भापाल, दिनांक 31/01/2020
 आदेश
 मुख्यप्रदेश शासन
 नगरीय विकास एवं आवास विभाग
 मंत्रालय, वल्लभ भवन, भापाल

368
True copy

- 1 निज सावित्र, प्रमुख सावित्र, म.प्र.शासन, राष्ट्रीय विकास एवं आवास विभाग, भोपाल।
- 2 निज सावित्र, आयुक्त, राष्ट्रीय प्रशासन एवं विकास, म.प्र., भोपाल।
- 3 समस्त आयुक्त, नगर पालिका निगम, मध्यप्रदेश।
- 4 मुख्य नगर पालिका अधिकारी, नगर पालिका/नगर परिषद, मध्यप्रदेश।
- 5 सामाजिक संचालक, नगरीय प्रशासन एवं विकास, मध्यप्रदेश।

भोपाल, मध्यप्रदेश
राष्ट्रीय विकास एवं आवास विभाग

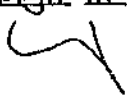
उप सावित्र

प्रतिनिधि :-
पृ.क्र./स्व.मा.सि./2020/3148 भोपाल, दिनांक 31/01/2020

भोपाल, मध्यप्रदेश
राष्ट्रीय विकास एवं आवास विभाग

(मनीष सिंह)
उप सावित्र

संलग्न : उपरोक्तानुसार।

- 2.5 भारत सरकार द्वारा जारी उपरोक्तानुसार 24 में उल्लिखित प्रावधानों हेतु संबंधित आयुक्त/मुख्य नगर पालिका अधिकारी आवश्यक सुझाव उपकरण, अधिकारी/कर्मचारी के प्रशिक्षण एवं सीवर/सैंटिक टैंक की जाफ सफाई के प्रबंधन हेतु उत्तरदायी सक्षम प्राधिकारी होंगे।
- 2.6 इसके लिए आपल कालीन सेवा टेलीफोन नंबर 101 (आनिशमन) अधिकृत टेलीफोन नंबर रहेगा। सीमा क्षेत्र में त्वरित सुविधाएँ उपलब्ध कराने के लिये उत्तरदायी होंगे।



Urban Development and Housing Department
Government of Madhya Pradesh

Standard Operating Procedure (SOP) for Cleaning of Septic Tanks and Sewers

75
आजादी का
अमृत महोत्सव



398
True copy!!

**STANDARD OPERATING PROCEDURE (SOP) FOR
CLEANING OF SEPTIC TANKS AND SEWERS**



**Urban Development and Housing Department,
Government of Madhya Pradesh**

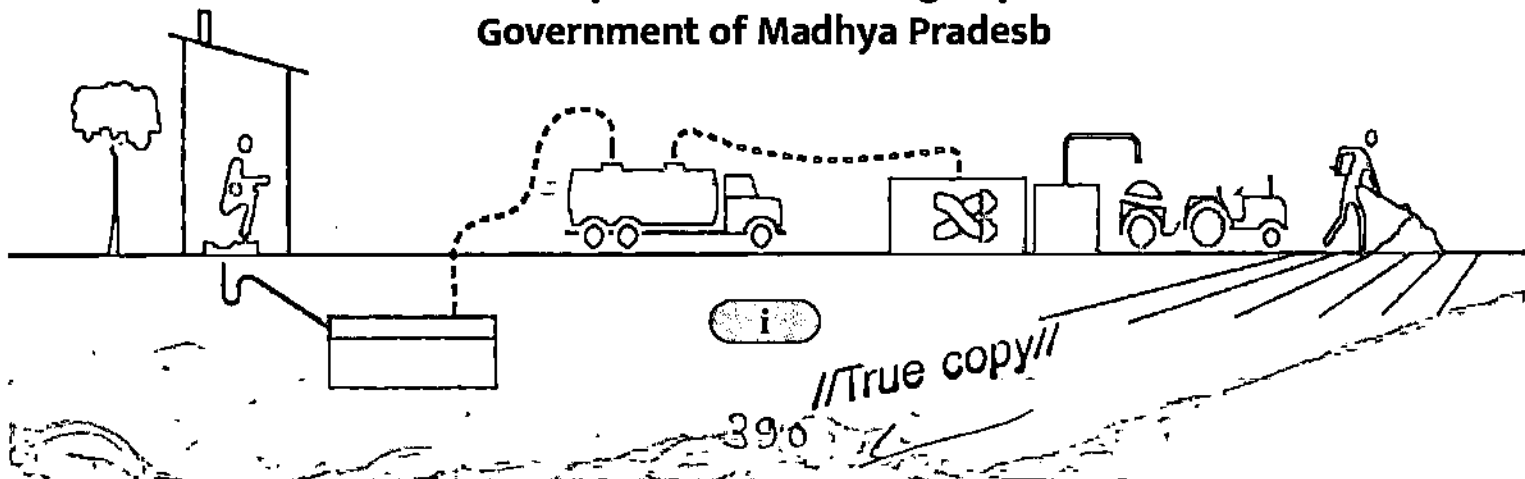

This book has been published with technical support from UNICEF.

Image credits for cover page:

Municipal Corporation - Bhopal, indore and Chhindwara (M.P.)



MESSAGE



Hon'ble Prime Minister has launched Swachh Bharat Mission (Urban) 2.0 on 1st Oct 2021. On the eve of 75th anniversary of Independence, this campaign will play a significant role in the effective management of the solid and liquid waste in urban areas of the State, making them completely free from piles of garbage, proper management of sludge from septic tanks and ensuring safety of the Safai Mitra's. Under this mission, special attention will be given to training the employees of the urban local bodies of the state and Safai Mitra's.

The government of Madhya Pradesh has taken many steps towards the use of machines for cleaning of septic tanks and sewers. Looking at the significance, the state government has already provided safety equipment to the urban local bodies under the Chief Minister's Samagra Swachhata Mission.

The practice of cleaning of septic tanks and sewers without proper safety equipment has to be stopped completely, so that our Safai Mitra's do not have to risk their lives. In this book, the process of cleaning septic tank and sewer by using machines and with proper safety equipment has been explained in a very simple language. I hope that this Standard Operating Procedure will be followed by the urban local bodies, contractors, Safai Mitra's, private organizations and residents of the state during the cleaning of septic tanks and sewers.

I congratulate the officials of Department of Urban Development and Housing Department, Madhya Pradesh and UNICEF for publishing this book in simple language.

Shivraj Singh Chouhan
Chief Minister
Government of Madhya Pradesh

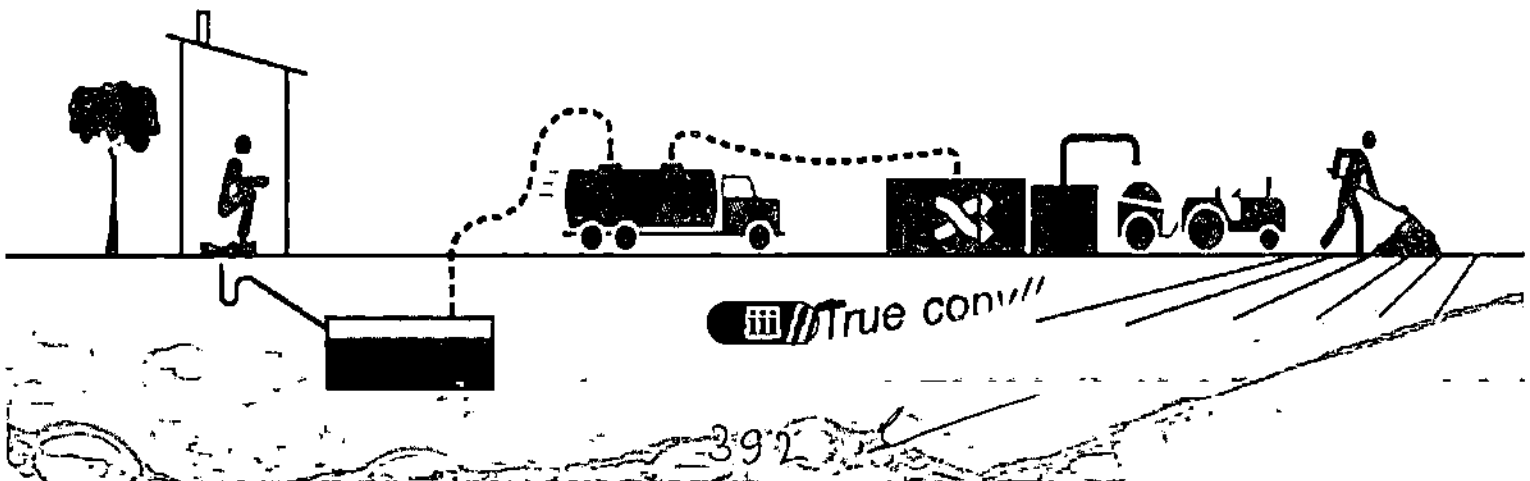

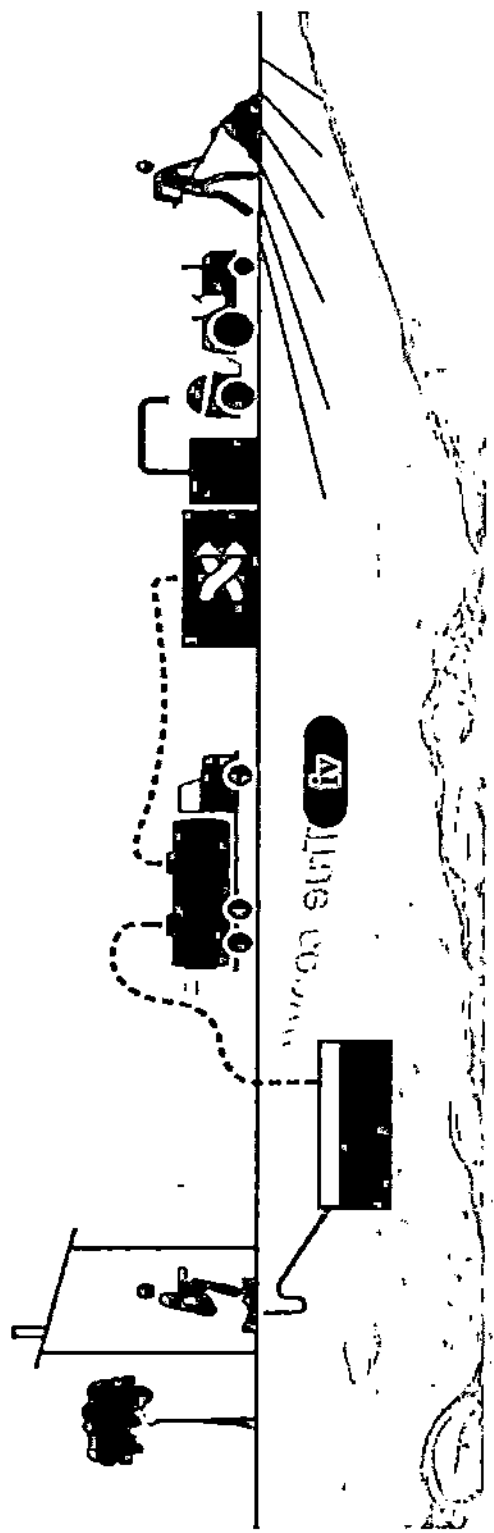

MESSAGE



The Government of India has notified "The Prohibition of Employment as Manual Scavengers and their Rehabilitation Act and Rules" in the year 2013 for the protection and safety of Safai Mitra's. This law prohibits the employment of manual scavengers, manual cleaning of sewers and septic tanks without safety equipment, and the construction of unhygienic toilets.

Under Swachh Bharat Mission (Urban) 1.0, 5.7 lakh individual household toilets and 20,000 community/public toilets have been constructed in the state. All these toilets need to be emptied in every 3 years and the sludge is to be treated scientifically at the Faecal Sludge Treatment Plant (FSTP). Apart from this, sewer lines are being constructed in urban areas under AMRUT and other schemes in the state. Regular maintenance of all these sewer lines needs to be done by the urban local bodies / contractors by using mechanical methods.

This Standard Operating Procedure will make a significant contribution towards the regular cleaning of toilets, tanks and sewer lines built in the state. I believe this will provide a safe environment to our Safai Mitra's while doing their work. I hope that this standard operating procedure will be widely used by all the urban local bodies of the state and its publicity will be done intensively.

Shri Bhupendra Singh
Minister, Government of Madhya Pradesh
Urban Development and Housing

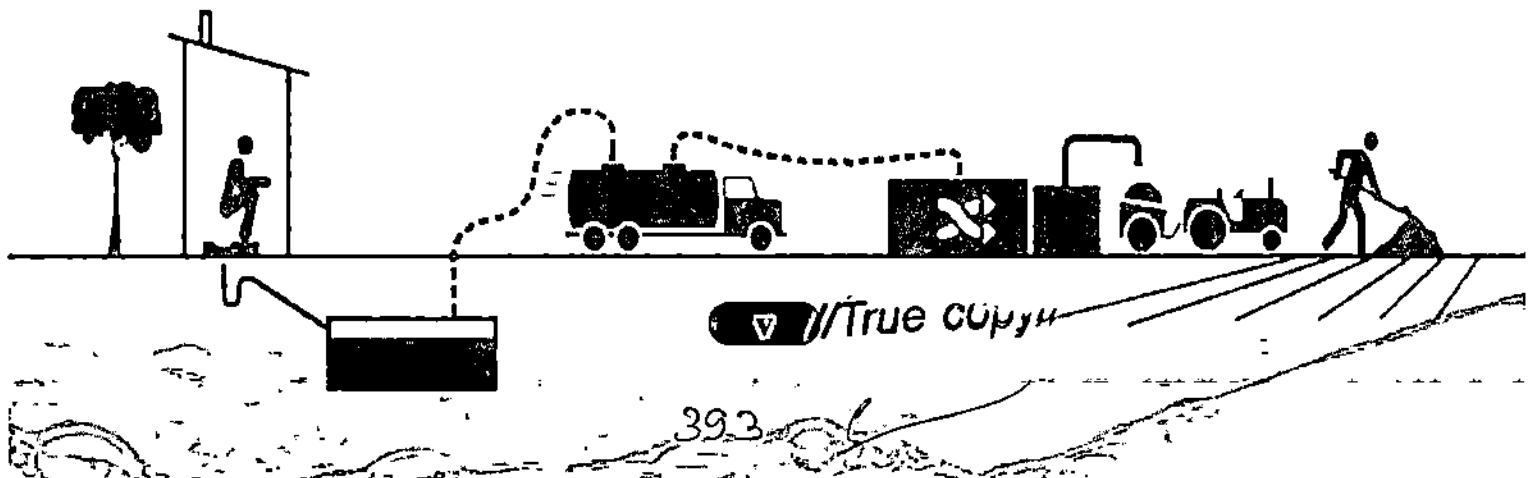

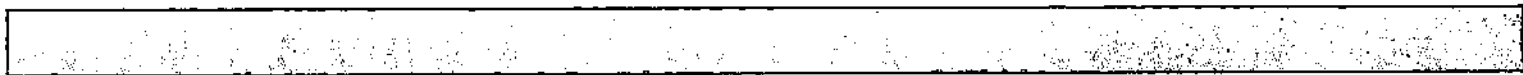
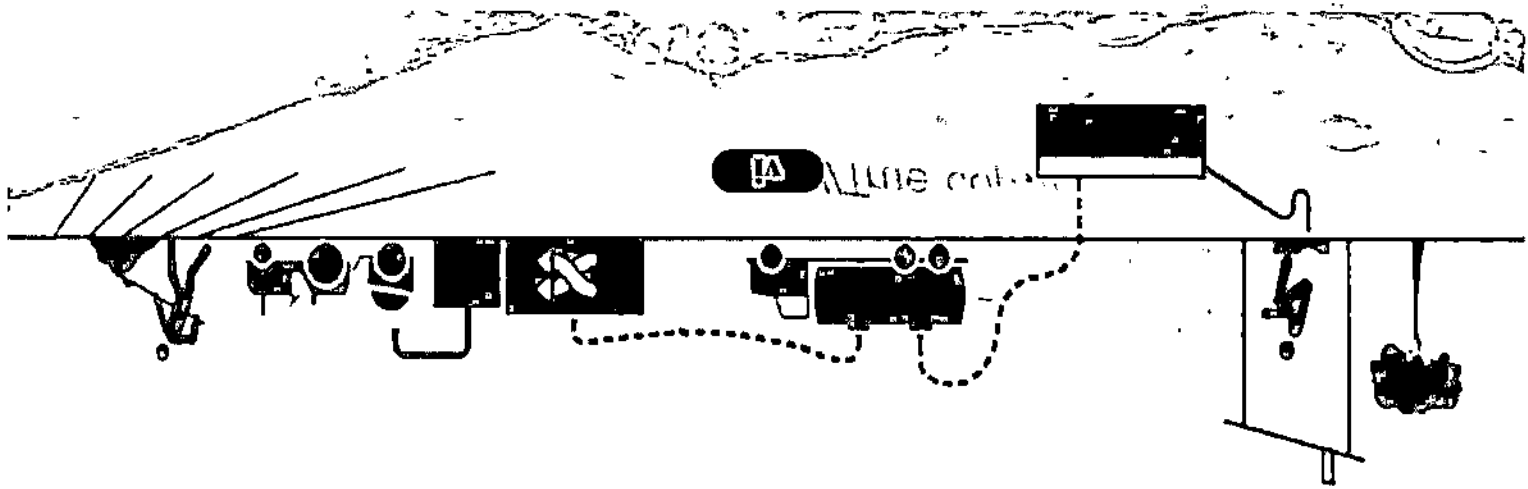

MESSAGE



Under the Swachh Bharat Mission, remarkable work has been done in the urban areas of the state. According to Swachh Survekshan 2021, 78 cities have been declared as ODF+ and 295 cities as ODP++. Indore is the first city in the country, which has ranked first position in the Swachh Survekshan for 5 consecutive years and is the first "Water Plus" city of the country.

In the year 2020-21, the Government of India had organized "Safai Mitra Suraksha Challenge" for 246 urban local bodies of the country, in which Indore and Bhopal have received the first and third position respectively in above 10 lakhs population category. Dewas has got the first place in the 3 lakhs population category.

The Government of Madhya Pradesh is committed for the safety and development of all our Safai Mitra's. I hope that every urban local body will take desired steps for their safety. The ULB needs to ensure that the cleaning of septic tanks and sewers are being carried out using latest equipment and the Standard Operating Procedures as described in this book to ensure the safety of our Safai Mitra's.

Shri O.P.S. Bhadaria
Minister of State, Government of Madhya Pradesh
Urban Development and Housing

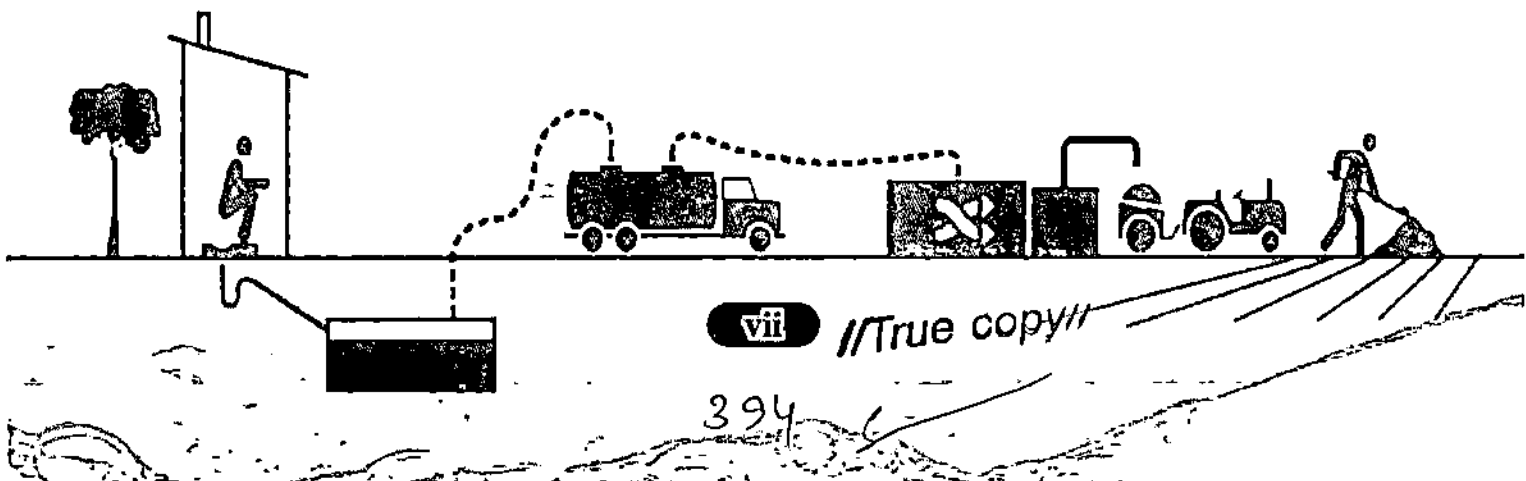

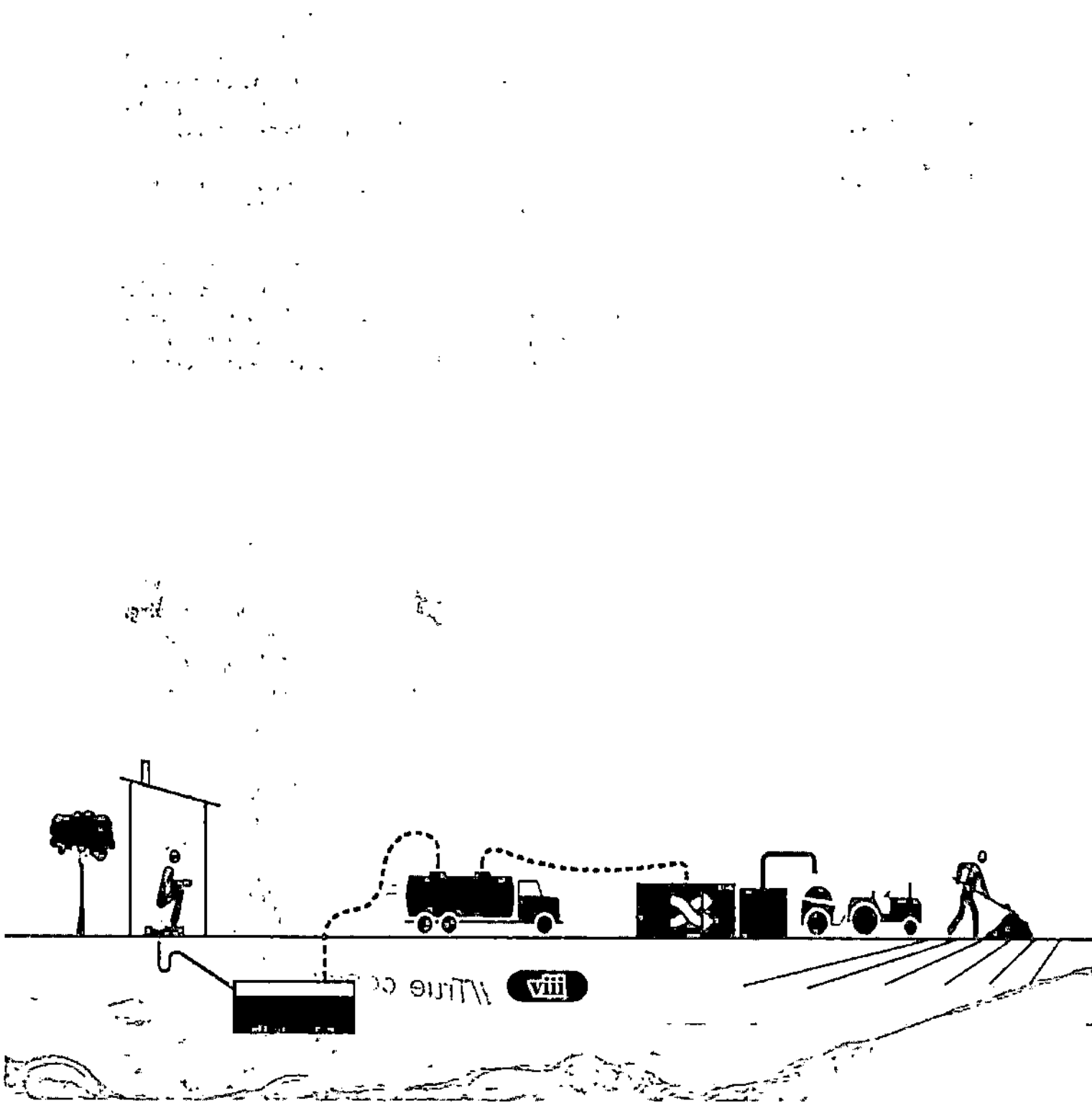

MESSAGE



Urban areas of the state have become open defecation free through Swachh Bharat Mission (Urban) 1.0, however there is a need for proper and safe management of sludge/liquid waste to boost total sanitation. The practice of emptying the septic tank, only when it is completely full, is commonly prevalent almost everywhere in the state. But according to the guidelines of the Government of India, every resident should get his/her septic tank emptied at least once in every 3 years.

While emptying the septic tank or cleaning the sewer lines, proper safety kit and equipment are to be used by the Safai Mitro's, so that their lives can be saved.

There is a need to work in a planned manner in the urban areas of the state. Arrangements has been made at the government level for the training of Safai Mitro's. Safety equipment's are also being provided to Safai Mitro's to work in a safe environment. In this direction, this book shall be used as guidelines for cleaning of septic tanks and sewers.

Shri Manish Singh
Principal Secretary
Government of Madhya Pradesh
Department of Urban Development and Housing

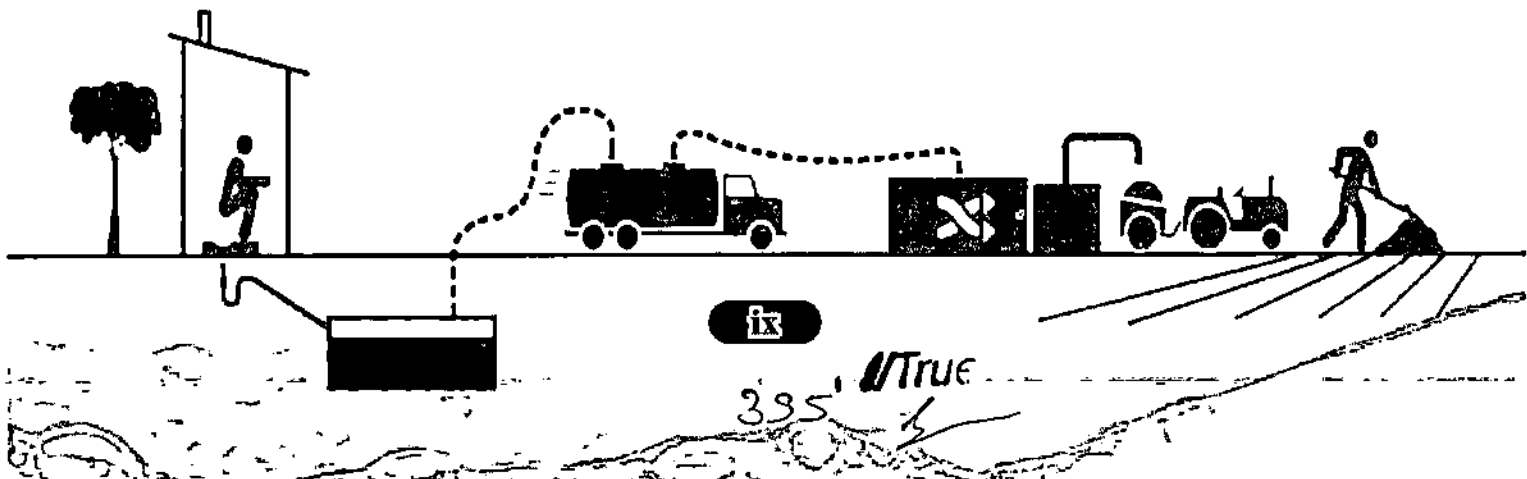

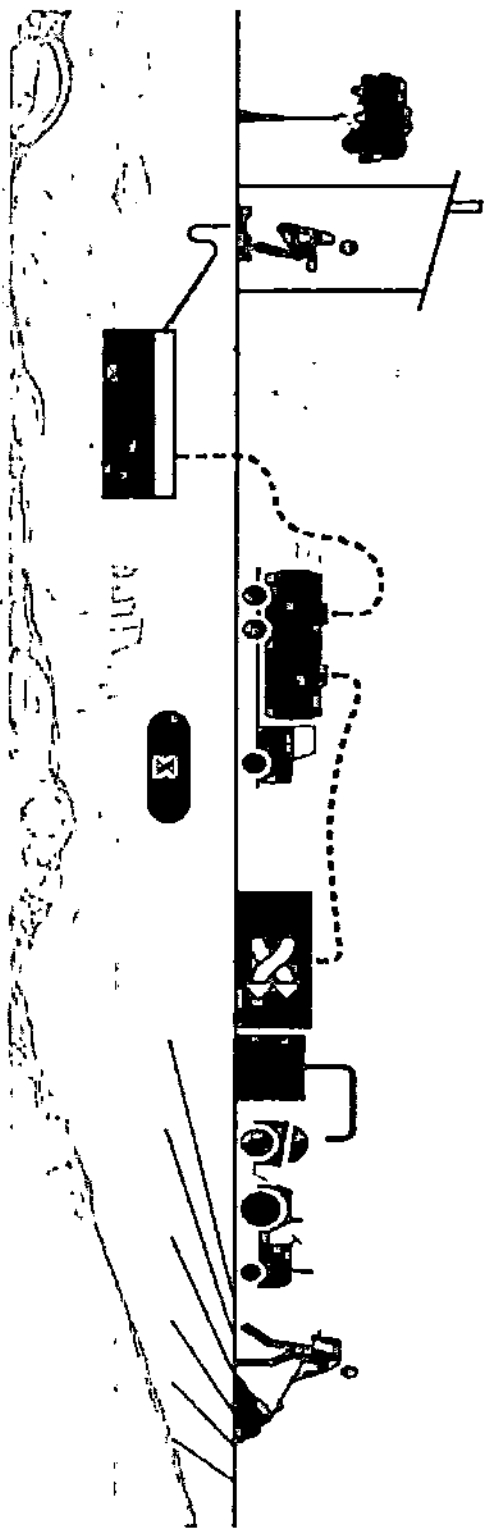

The diagram illustrates the layout of a mobile laboratory or field station. The central horizontal line represents the vehicle or transport unit. On the left side, there is a person sitting at a workstation, a rectangular control panel, and a person standing near a ramp. On the right side, there is a person sitting at a workstation, a large piece of equipment with a circular dial, a person standing near a ramp, and a person walking. A dashed line indicates a path or connection between the control panel and the large equipment. The word "ARTV" is written vertically on the left side of the diagram.

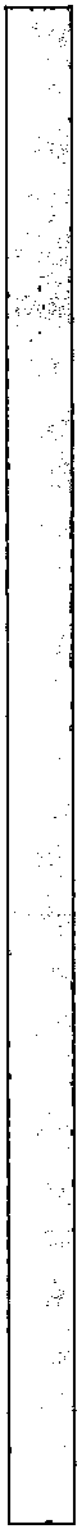

MESSAGE



Our Safai Mitro's are loosing their lives during cleaning of sewers and septic tanks manually without any safety gear/equipment. According to the directions of the Hon'ble Supreme Court, there is a provision to provide compensation up to Rs 10 lakh to the family of the deceased person in case of the death of Safai Mitra during the cleaning of sewer/septic tank. But we have to save our Safai Mitro's from accidents that happen during cleaning of septic tank and sewer.

In this book, information about the equipment, safety kit, PPE kit, tools etc. that should be given to Safai Mitro's are described. Apart from this, a check list of the work to be done before cleaning the sewer and the before entering the sewer chamber (machine hole) has been given in this book.

While cleaning the sewer and septic tank in all the urban areas of the state, it needs to be ensured that the Standard Operating Procedure and the check lists given in this book are being strictly followed. Apart from this Safai Mitro's should be trained and provided with safety gears/equipments.

Shri Nikunj Srivastava

Commissioner

Department of Urban Administration and Development

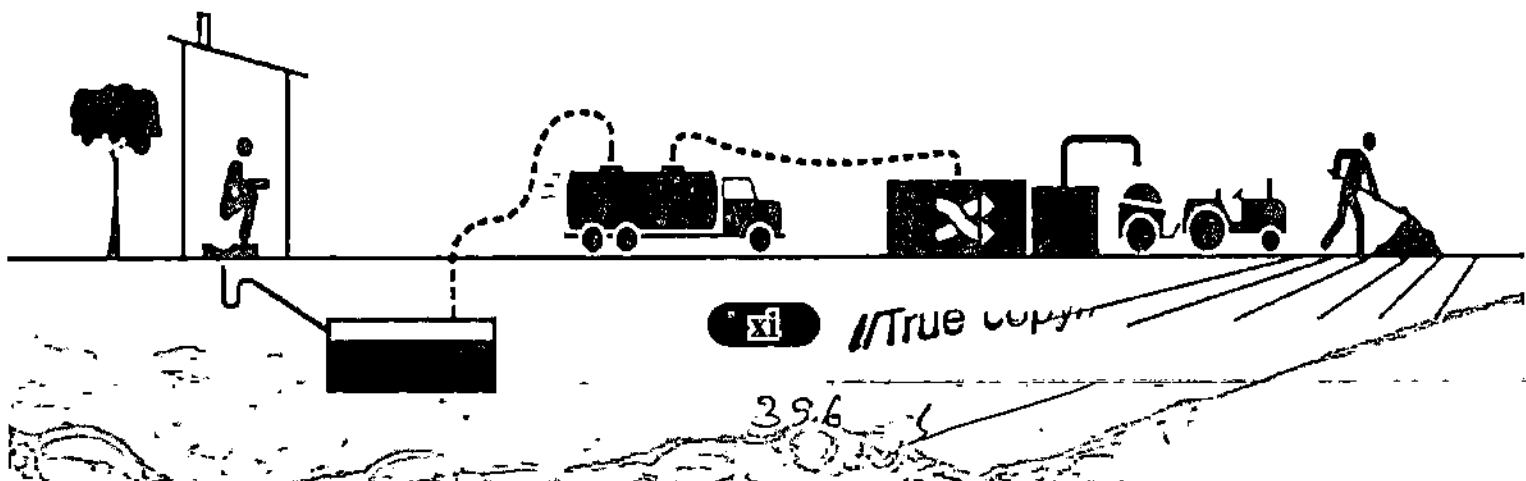

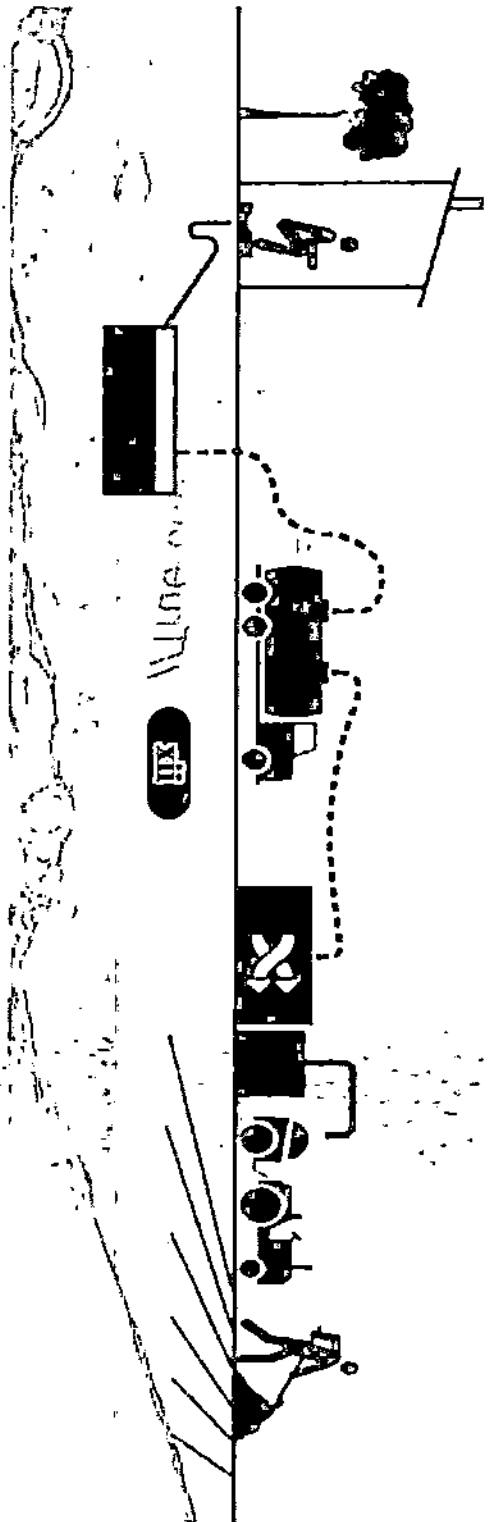

1. The first stage of the process is the preparation of the raw materials. This involves the selection and sorting of the materials, followed by their cleaning and drying. The quality of the raw materials is crucial for the final product.

2. The second stage is the production of the intermediate products. This is done by mixing the raw materials in specific proportions and then processing them through a series of steps. The 'K' symbol likely represents a specific processing step or a quality control point.

3. The third stage is the final production of the product. This involves further processing of the intermediate products, including the addition of any necessary ingredients and the final packaging. The 'Wine' label indicates the final product being produced.

4. The final stage is the distribution and sale of the product. This involves transporting the product to the market and ensuring it reaches the consumer in good condition. A worker is shown at a station on the right, likely involved in the packaging or distribution process.

The diagram also shows a worker at a station on the left, which is likely the starting point of the production process. A small building with a person inside is located at the top right of the diagram, possibly representing a control room or a storage area.



TABLE OF CONTENTS

Chapter - 1:	introduction	01
Chapter - 2:	Provisions and Acts	05
Chapter - 3:	Procedure for Emptying Septic Tanks	13
Chapter - 4:	Procedure for Cleaning of Sewer	25
Chapter - 5:	Emergency Preparedness and Precautions	44
Chapter - 6:	Protective Gear and Safety Equipment	49
Chapter - 7:	Guidelines for selection of Safai Mitra's for Sewer / Septic Tank Cleaning	52
Chapter - 8:	Roles and Responsibilities	54
ANNEXURE		
Annexure - i:	Standard Uniform and PPE Kit for Safai Mitra's	57
Annexure - II:	Information Related to the Construction of Septic Tank - (Do's and Don'ts)	63
Annexure - III:	Sample Questionnaire for Household Survey	67
Annexure - IV:	Format of Daily Reporting (Related to Emptying of Septic Tank)	73
Annexure - V:	Form to be filled after emptying the septic tank	74
Annexure - VI:	Check List Before Starting Sewer Cleaning Work	77
Annexure - VII:	Check List Before Entering Machine Hole	79
Annexure - VIII:	Items Listed in First Aid Kit	81
References		82

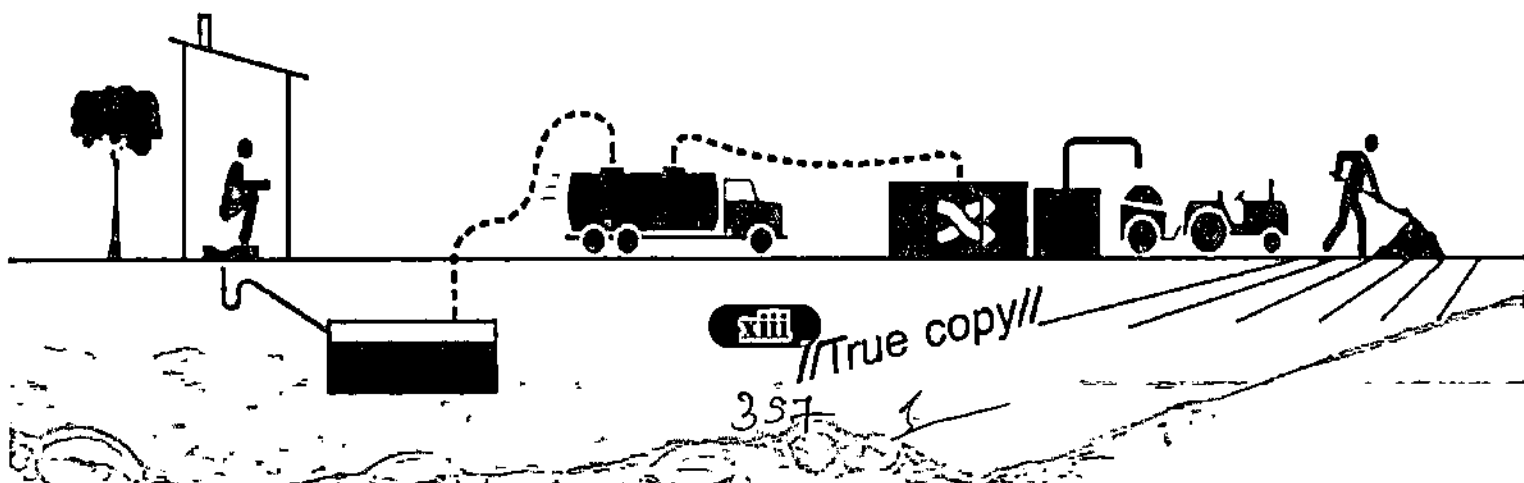

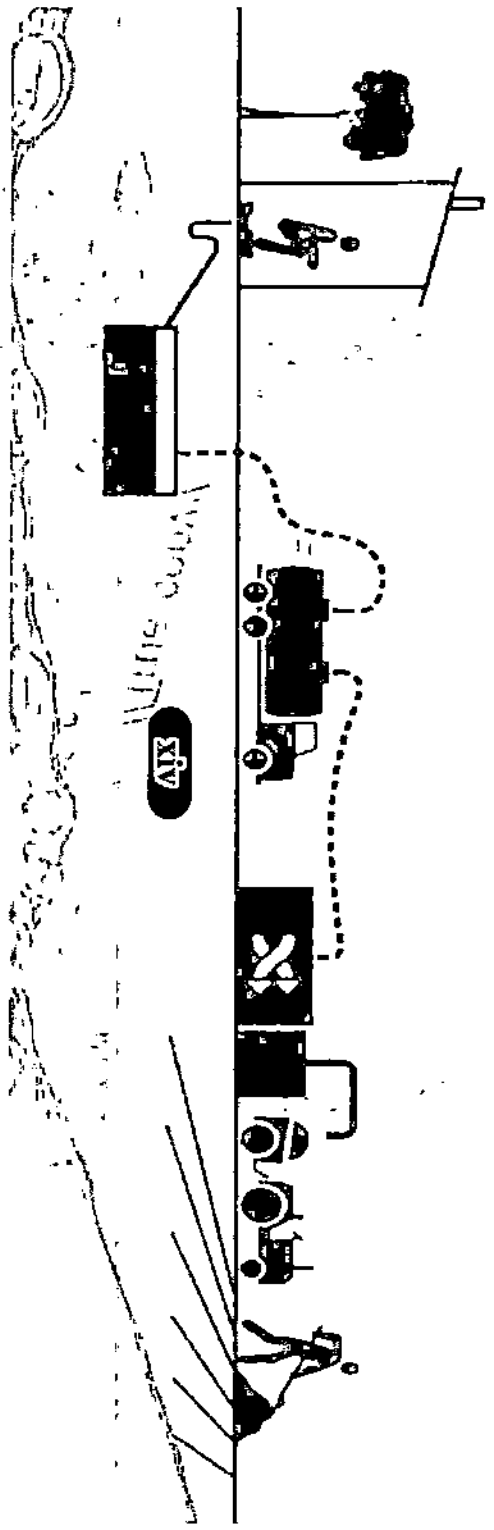

The diagram illustrates a control system for a mining operation. It shows a sequence of components connected by a dashed line, representing a conveyor or material flow system. The components include a person, a wheel, a gear, and a cross, which likely represent different stages of material processing or transport. A truck is positioned in the middle of the line, indicating its role in the system. To the right, a person is seated at a control station, which is connected to the system via a dashed line. A rectangular box with the Greek letter Δ (delta) is labeled "Mining Control", suggesting it is the central control unit for the operation. A vertical line runs through the center of the diagram, possibly representing a structural element or a boundary.



CHAPTER -1

INTRODUCTION

1.1 Introduction

Swachh Bharat Mission (Urban) 2.0 has been launched by Hon'ble Prime Minister of India on 1st October 2021. The mission aims at achieving outcomes in terms of total sanitation and solid waste management and to accelerate the work done during the Swachh Bharat Mission 1.0.

Under this mission, over 3.5 lakh individual household and community/public toilets will be constructed at the national level during the next 5 years. Also, complete liquid waste management will be ensured in cities with population less than one lakh. Systems and processes will be developed in every city to safely collect, transport, and treat liquid waste as well as to protect our water resources from getting polluted.

Under Swachh Bharat Mission (Urban) 1.0, Madhya Pradesh has been declared an ODF state in 2017 and total 5.7 lakh individual household toilets and 20,000 community/public toilets have been constructed in the state. According to Swachh Survekshan 2021, 78 cities have been declared as ODF+ (Open Defecation Free Plus) and 295 cities as ODF++. Indore is the first city in the country, which has ranked first position in the Swachh Survekshan for 5 consecutive years and is the first "Water Plus" city of the country.

In the year 2020-21, the Government of India had organized "Safai Mitra Suraksha Challenge" for 246 urban local bodies of the country, in which Indore and Bhopal have received the first and third position respectively in the category of population above 20 lakhs. Dewas has got the first place in the category of population up to 3 lakhs.

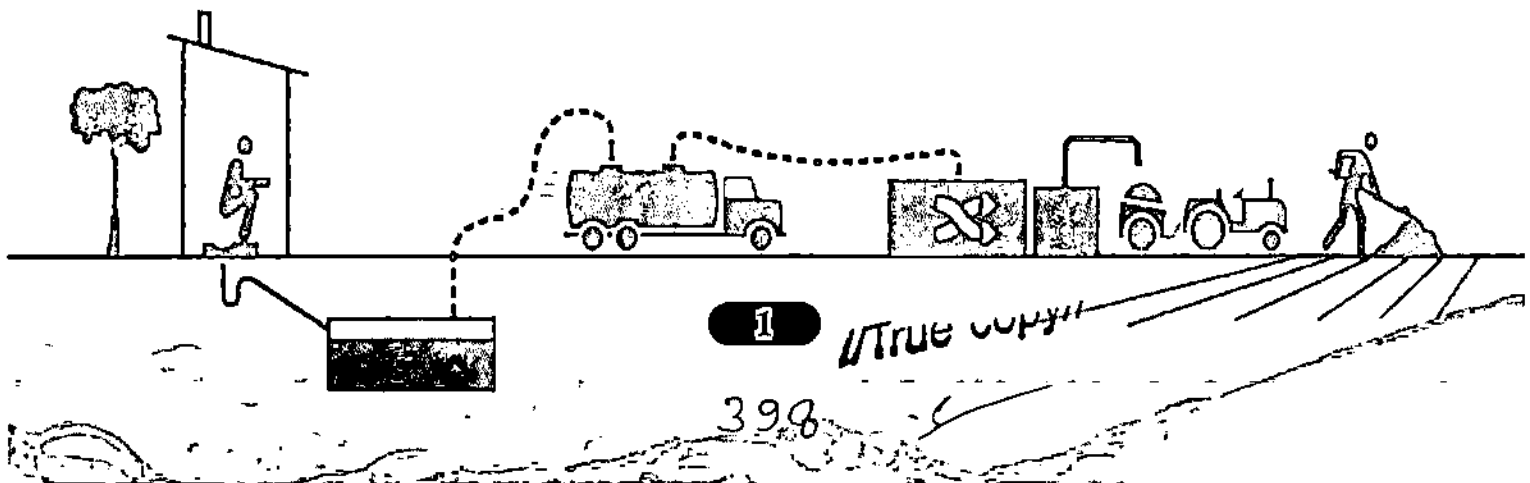

Government of India had notified "Prohibition of Employment as Manual Scavengers and their Rehabilitation Act, 2013 and Rules 2013". Under this law, provision for rehabilitation of manual scavengers and alternative employment to them is also to be made in a time bound manner. The construction and maintenance of insanitary latrines is an offense under this law, and no one can be employed or employed as manual scavengers.

The law prohibits the employment of manual scavengers, manual cleaning of sewers and septic tanks without safety equipment, and the construction of insanitary latrines. As per this law, the sewage is to be completely emptied before any person is allowed to enter the sewer for reconstruction/maintenance of machine hole or improvement of sewer line.

Working near or in a machine hole inherits potential dangers which may impact in serious accidents and in some extreme cases, death as well. The common accidents include falls/ slips, fire or explosion, oxygen depletion, gas poisoning, heat stress, drowning, asphyxiation arising from gas, fume, vapour, and entrapment by free-flowing solids. Amongst these, dangerous gases are easily overlooked or neglected, leading to serious casualties.



Photo Credit: Nagor Palik Nigam, Indore

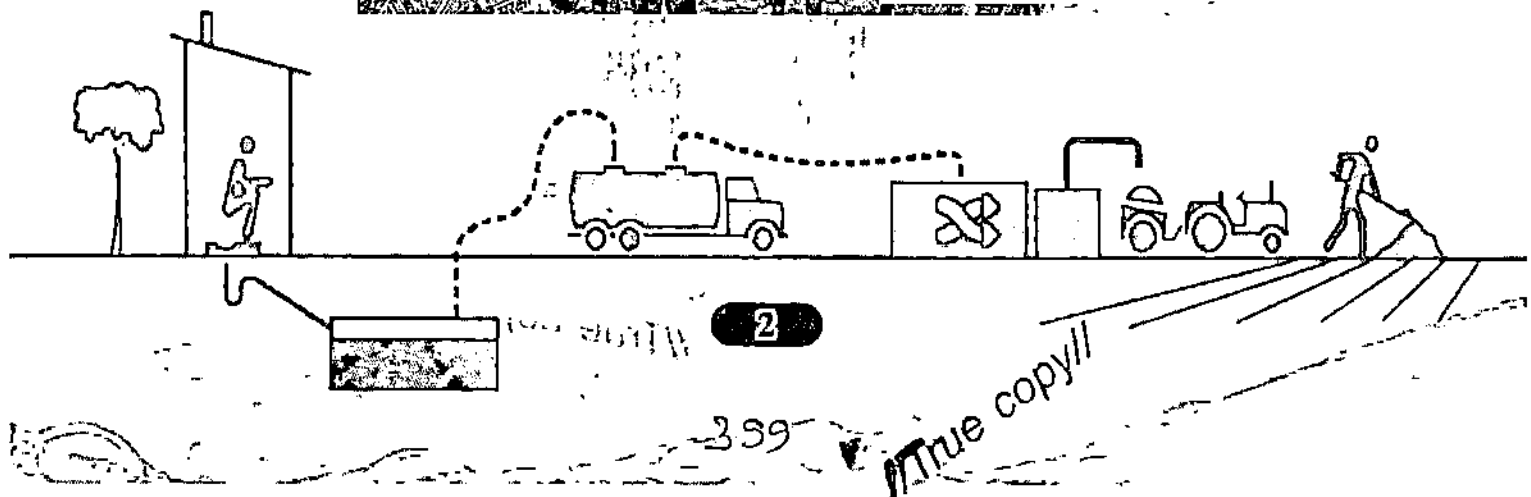

The health and safety of Safai Mitra's can be safeguarded to a great extent by use of safety equipment and by taking precautions appropriate for each hazard condition.

To cater the issues of hazardous cleaning, this Standard Operating Procedure (SOP) discusses on the precautionary steps to be followed while cleaning of sewers and desludging of septic tanks. Further, the document also enlightens ideas on various mechanized sewer & septic tank cleaning procedure and technologies to eradicate hazardous cleaning.

1.2 Scope

The scope of the SOP is to develop an understanding to all the stakeholders about the cleaning of sewers and emptying of septic tanks before and after the task.

This document would be found useful by all Urban Local Bodies (ULBs), Public Health Engineering Departments and other agencies engaged in the process of cleaning of sewers/emptying of septic tanks across the State. Further, the procedures mentioned in this SOP shall also be applicable to the contractors who employ person(s) for cleaning of sewers/ emptying of septic tanks and the individuals who hire such person(s) for cleaning of their sewers/emptying of septic tanks in their respective locations.

1.3 Objective

The main objective of this SOP is to eliminate hazardous cleaning or at least to avoid the accidents due to improper practice of cleaning of sewers/ emptying of septic tanks, thereby, preventing human casualties.

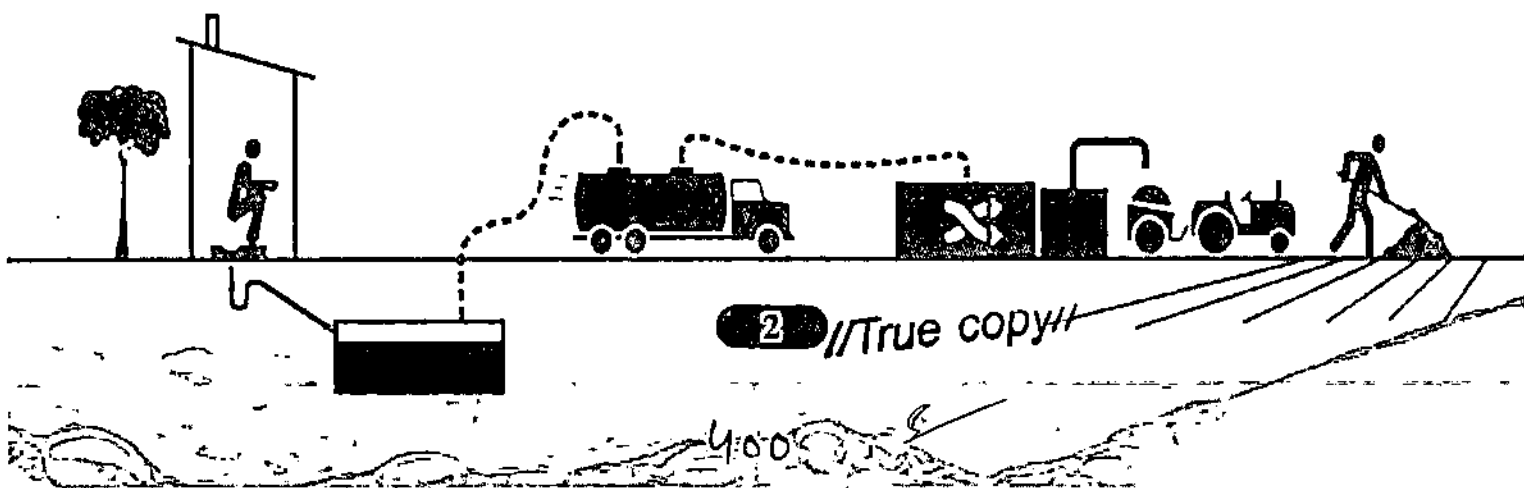

Further, the SOP intends to prevent the risk of acquiring diseases to the Safai Mitra's because of following unhygienic & unscientific working procedures.

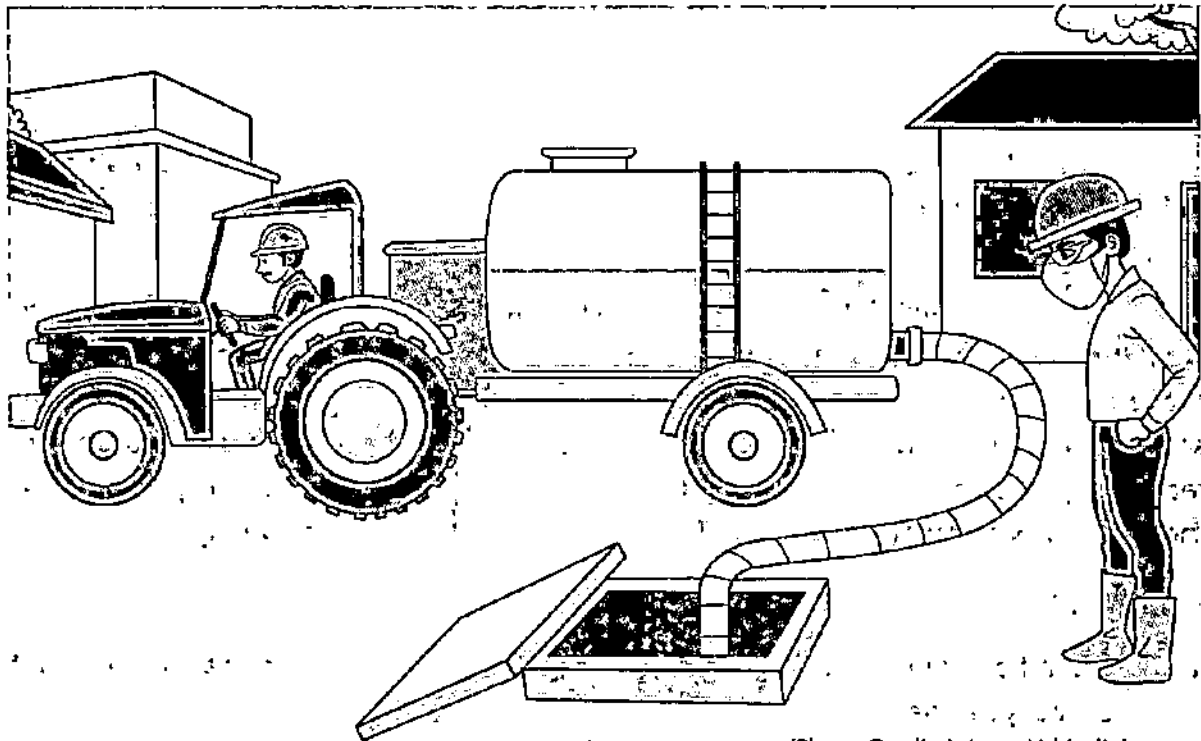

(Photo Credit: Water Aid India)

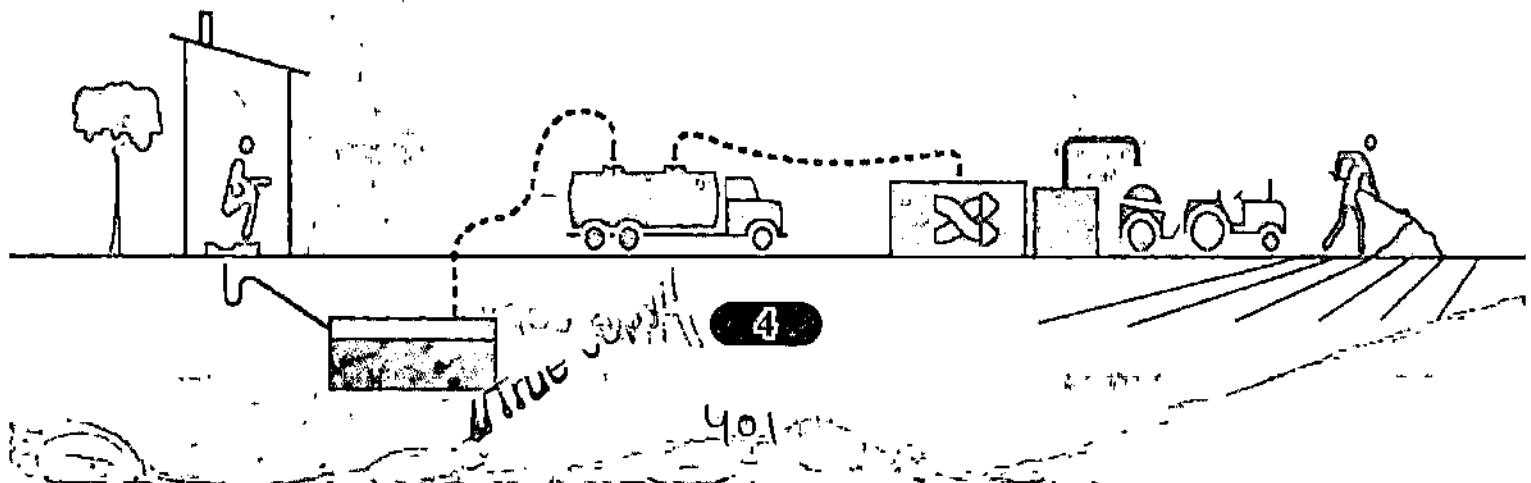

CHAPTER - 2

PROVISIONS AND ACTS

2.1 Prohibition of Employment as Manual Scavengers and their Rehabilitation Act, 2013

This act prohibits "hazardous cleaning" of sewer/septic tanks. Under this act nobody can employ or recruit anybody directly or indirectly for manual cleaning of sewers and septic tanks.

Further, the Act defined that a person engaged or employed to clean excreta with the help of such devices and using such protective gear, as the Central Government may notify in this behalf, shall not be deemed to be a 'manual scavenger'. It is the duty of every local authority and other agency to use appropriate technological appliances for cleaning of sewers, septic tanks, and other spaces within their control with a view to eliminate the need for the hazardous cleaning.

Main features of the Act are:

1. Definitions of manual scavengers and insanitary latrines widened to cover not only dry latrines but other insanitary latrines as well.
2. Offences under the Act are cognizable and non-bailable and attract stringent penalties.
3. Vigilance/Monitoring Committee at sub-Division, District, State and Central Govt. levels.
4. National Commission for Safai Karamcharis (NCSK) would, inter alia, monitor implementation of the Act and enquire into complaints regarding contravention of the provisions of the Act.
5. Provision of construction of adequate number of sanitary community latrines in

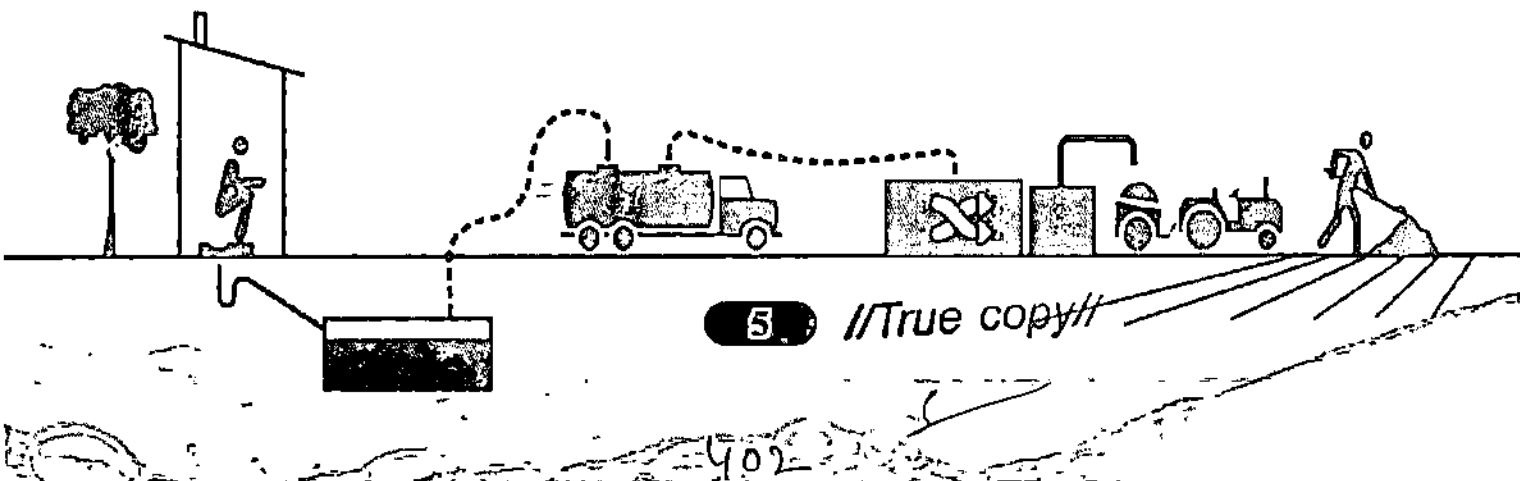

urban areas, within three years from the date of commencement of this Act to eliminate the practice of open defecation.

Please click the link below for more details about this Act:

<https://socialjustice.nic.in/writereaddata/UpladFile/manualsca-act19913635738516382444610.pdf>

2.2 Prohibition of Employment as Manual Scavengers and their Rehabilitation Rules, 2013

Prohibition of Employment as Manual Scavengers and their Rehabilitation Rules, 2013 has been notified by Ministry of Social Justice and Empowerment under the provisions of Prohibition of Employment as Manual Scavengers and their Rehabilitation Act, 2013. As per the Rules, no person shall be allowed to clean a sewer manually, with the protective gear and safety devices except

1. for the removal of concrete or FRP (Fiber Reinforced Plastic) or damaged machine hole door where mechanical equipment's cannot be put into operation.
2. for inter-linking the newly laid sewer main with the existing sewer main, in case of sewer of size more than 300 mm diameter.
3. for removal of submersible pump sets fixed at the bottom of the suction wells of sewage pumping stations / STP.
4. for the reconstruction of the machine hole or rectification of the sewer main.
5. Any circumstance, when it is necessary to have manual sewage cleaning, after Chief Executive Officer (CEO) or Head of the Local Authority has permitted to do so after recording in writing the specific valid reasons for allowing such cleaning.

The Rules requires to monitor and oversee the survey of manual scavengers at District and State level, District Level Survey Committee. It mandates a State Level Survey Committee should be constituted, and to publish final consolidated list of

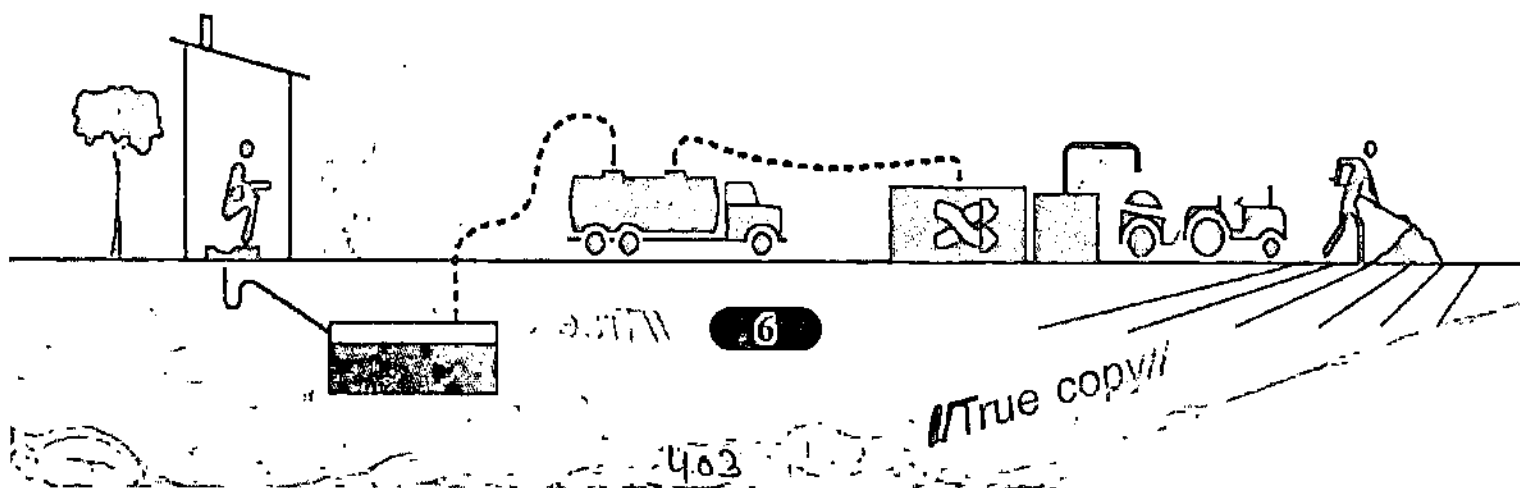

manual scavengers in the State.

Please click the link below for more details about this Rule:

<https://socialjustice.nic.in/writereaddata/UploadFile/manualsca-rules2013.pdf>

2.3 National Safai Karamcharis Finance and Development Corporation (NSKFDC)

The National Safai Karamcharis Finance and Development Corporation have been set up as a "Not-for-Profit Company" under Section 25 of the Companies Act, 1956 under the Ministry of Social Justice and Empowerment, Government of India on January 24, 1997". NSKFDC is functioning as an apex organization for all round socio-economic upliftment of Safai Karamcharis and their dependents across India. Apart from implementing loan based and non-loan-based schemes for the upliftment of Safai Karamcharis, NSKFDC is also playing a vital role in the eradication of "Manual Scavenging System". NSKFDC has also been made the nodal agency for implementation of "Scheme for Self Employment and Rehabilitation for Manual Scavengers" under Ministry of Social Justice and Empowerment, GOI.

Implementation of the schemes/programmes of NSKFDC is being done through the State Channelizing Agency (SCA) nominated by the State Government and Regional Rural Banks and Nationalized Banks disburse the amount for any income generating activity including sanitation activities at concessional interest rates to the target groups of NSKFDC.

For more information regarding this scheme use the following link –

<https://nskfdc.nic.in/>

2.4 Sanitation Response Unit

Ministry of Housing and Urban Affairs has issued the guidelines on Emergency Response Sanitation Unit (ERSU) during the year 2019. It is compulsory to set up

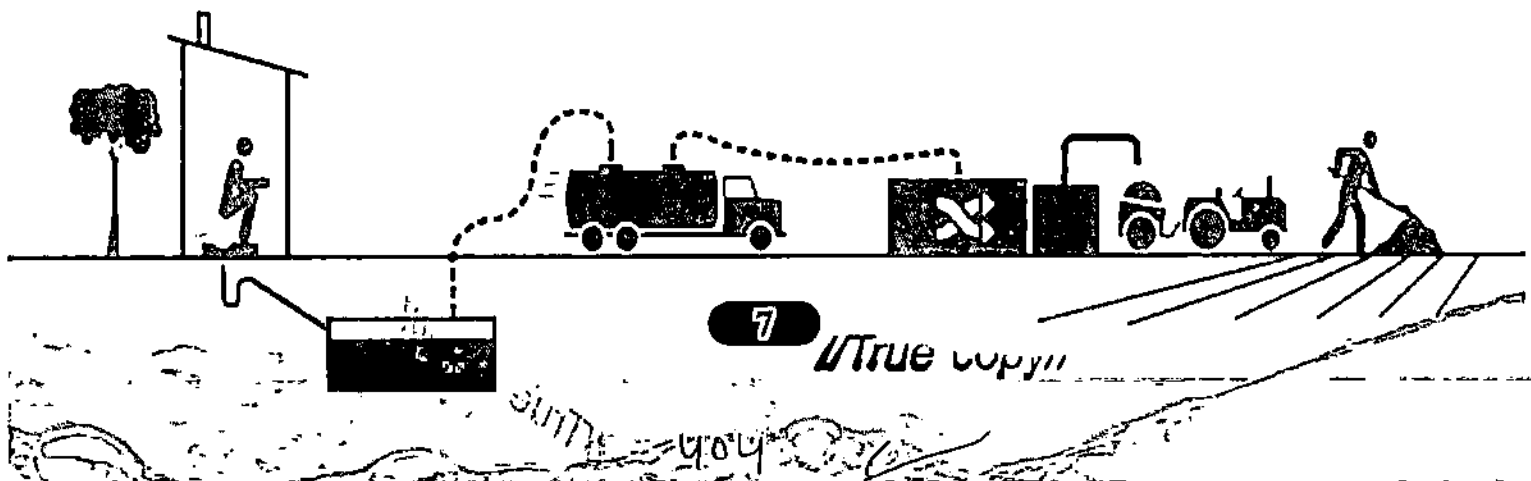

ERSU in each district to protect the lives of Safai Mitra's during cleaning of sewers and septic tanks. ERSU is also responsible to provide technical and managerial guidance to the Urban Local Bodies.



State/UT Government



RSA



ERSU



PSSO



SEP/pSEP



Photo Credit: ERSU Avisory published by CPHEEO

*RSA - Responsible Sanitation Authority, SEP - Sewer Entry Professionals, PSSO- Private Sanitation Service Organization

2.4.1 Objective of ERSU

The main objective of the ERSU is to provide professional, well trained, motivated and appropriately equipped workforce for the maintenance and management of sewers and septic tanks, thereby eliminating the deaths caused by entry of workers into sewers and septic tanks without proper PPEs & training and nonadherence to security protocols.

2.4.2 Roles and Responsibilities of ERSU

1. State/UT may designate the District Magistrate or Municipal Commissioner of a major town (designated as the base town) as Responsible Sanitation Authority (RSA) for his own jurisdiction as well as smaller clustered towns.

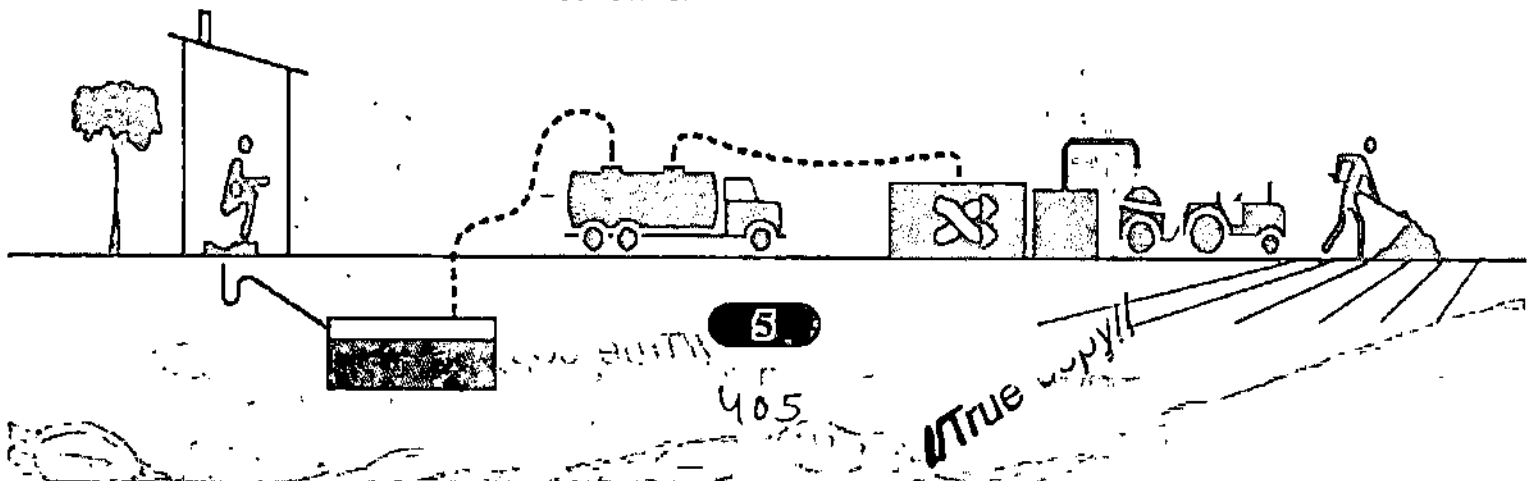

2. Staff for ERSU will be arranged by the RSA. It shall consist of a headquarters and a 24x7 response contact number.
3. Sewer Entry Professionals (SEPs) may preferably be selected from traditionally employed sanitation workers. They must be comprehensively trained on their job and safety/security measures so that they do not risk their lives in cleaning of sewer/septic tanks.
4. It is not necessary to employ all the SEPs on permanent government strength. Professionally trained and equipped Private Sanitation Service Organizations (PSSOs) may also be empanelled by respective ERSUs to provide an assured number of private SEPs (pSEPs) and equipment sets. These PSSOs should also preferably employ those persons who have been traditionally engaged in sewer/ septic tank cleaning in the area;
5. RSA should procure adequate full sets of protective equipment (both personal and institutional) and maintain them at optimal efficiency at all times. Whenever, a SEP Team is tasked to carry out the job, they may be issued the protective gear and other equipment and should be allowed to do the job under Supervision of a trained officer of RSA.
6. Entry of any individual other than member of a trained SEP Team specifically deputed from ERSU into sewers or septic tanks without permission of ERSU shall be deemed contravention of the PEMSRA Act, 2013, such individuals and the entity/ person allowing such entry directly or indirectly, will be held criminally liable under the Act. RSA will be empowered take necessary action in this regard. The RSA will notify charges/ fees for services provided by ERSU from time to time, which shall be binding on the smaller cluster towns dependent on the ERSU.

For more information regarding ERSU, please visit the following link-

https://niu.org/scbp/sites/default/files/Advisory_on_Emergency_Response_Sanitation_Unit_0.pdf

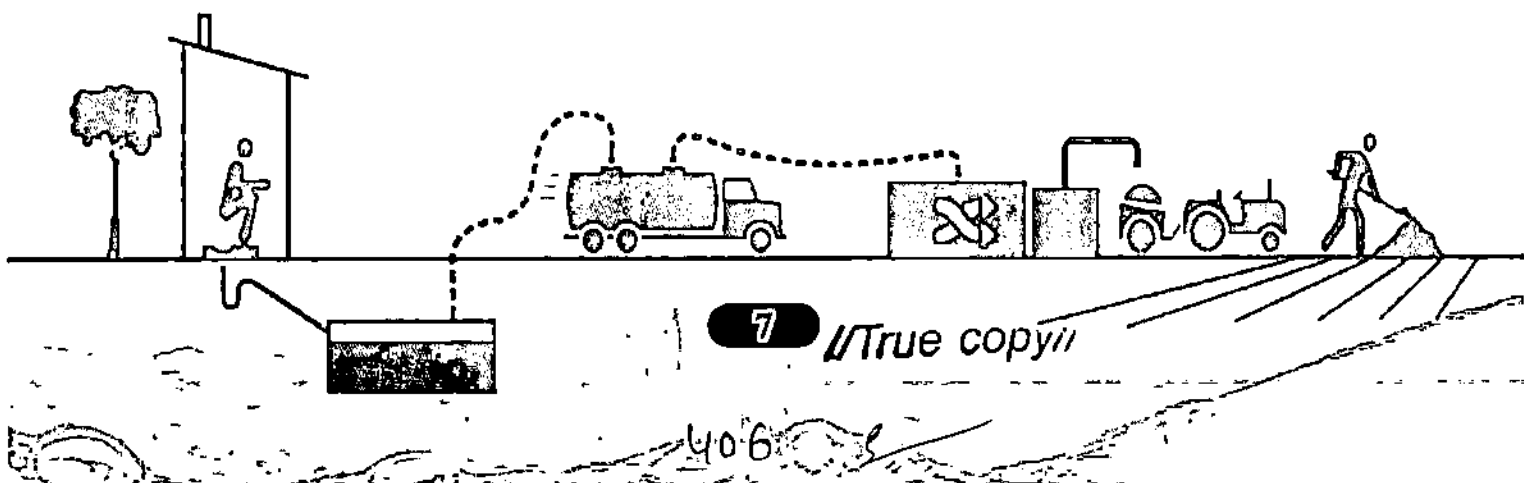

2.5 Swachh Bharat Mission 2.0 (Urban)

Under this mission, equipment's and safety kits are to be given to the Safai Mitra's for their personal safety and welfare and special attention to be paid for their welfare and capacity building by linking them with welfare schemes of the government.

For more information regarding Swachh Bharat Mission 2.0 (Urban) visit the following link – <https://sbmurban.org/>

2.6 Safai Mitra Suraksha Challenge -

On the occasion of World Toilet Day 19th November 2020, "Safai Mitra Suraksha Challenge" has been launched by the Government of India. The objective of this challenge is to promote urban bodies for mechanised cleaning of sewers and septic tanks, so as to save the lives of Safai Mitra's. Apart from this, the challenge is to provide proper protective gears and equipment to Safai Mitra's, capacitate them and identification of informal workers and thereby integrating them into formal mechanism. In "Swachh Survekshan 2022", 360 points will be given on the basis of work done by the urban body for "Safety of Safai Mitra".



For more information regarding the Safai Mitra Suraksha Challenge, visit the following link – <https://safaimitrasurakshachallenge.org/>

2.7 Uniform for Safai Mitra's -

The Government of India, through an order dated 8 March 2021, has decided the standard uniform for Safai Mitra's. For detailed information see Annexure - 1.

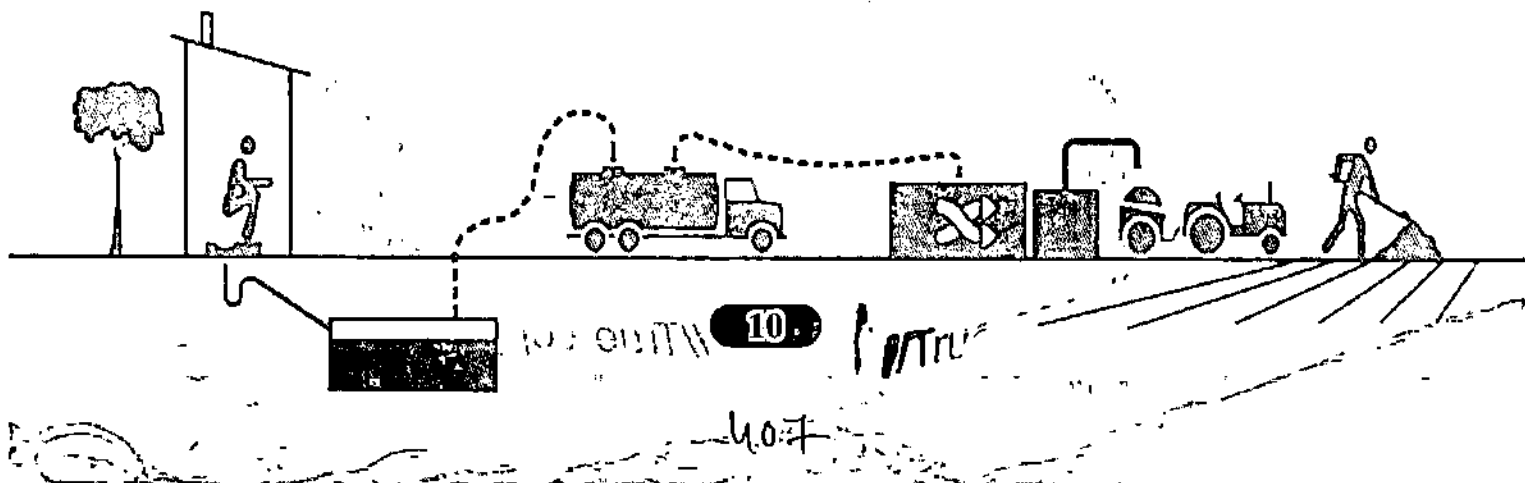

2.8 Call Center Number "14420"

Government of India has issued directives to fix the call centre number "14420" for cleaning of septic tanks and sewers. In this context, call centre should be established and operated by all urban bodies so that the incidences of septic tank / sewer line blockage can be resolved immediately, and regular cleaning of septic tank / sewer line can be done.

2.9 AMRUT - 2.0

Under this mission, projects are being implemented in urban areas for the management of sewerage and septage. STPs and faecal sludge treatment plants (FSTP) are being installed in urban areas and necessary resources are being made available for mechanised cleaning of sewers and septic tanks.

For more information regarding AMRUT 2.0 Mission, visit the following link –
<https://mohuo.gov.in/uplaad/uplaadfiles/files/AMRUT-Operational-Guidelines.pdf>

2.10 IS 11972 – 2002: Code of Practice for Safety Precautions to Be Taken When Entering a Sewerage System

This standard lays down guidelines for selection of sewer men and safety measures against gas hazard, infection with a view to provide some basic guidance for selection of employees for sewer cleaning and proper job instructions for safe working in a sewerage system.

For more information regarding this code, refer to the following link –
<https://www.services.bis.gov.in:8071/tmp/SR11972.pdf>

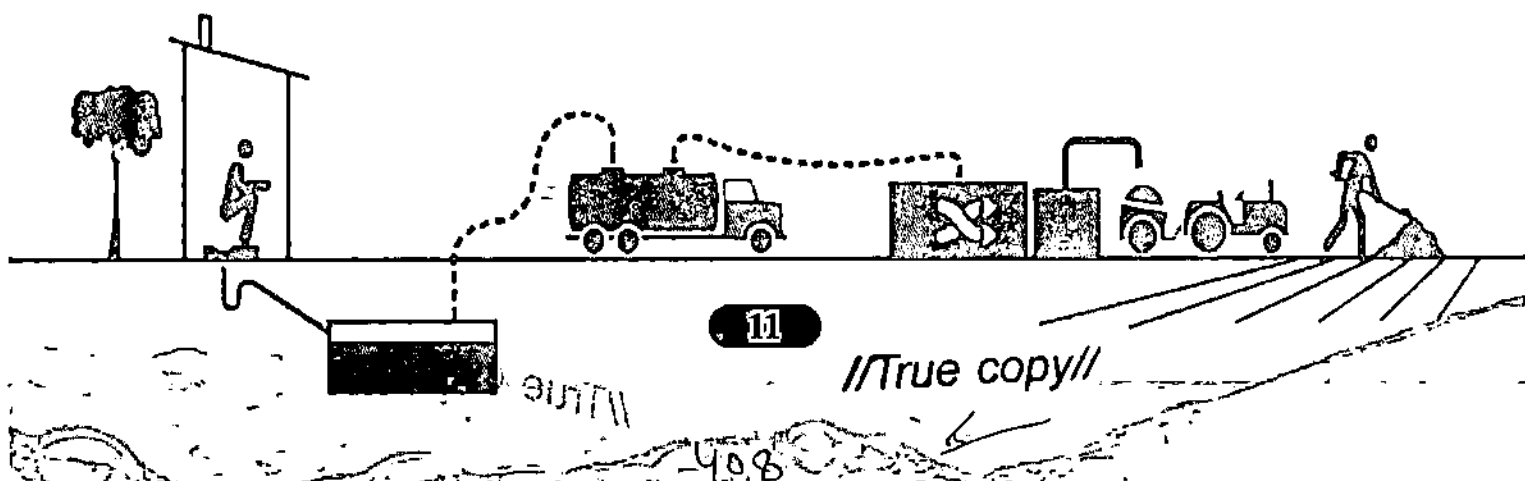



Photo Credit: Municipal Corporation, Indore

2.11 Manual on Sewerage and Sewage Treatment System, 2013

The Ministry of Housing and Urban Affairs, Government of India has published the manual on Sewerage and Sewage Treatment System in the year 2013. In this manual, the cleaning of sewerage by manual and mechanized methods and cleaning of septic tanks without human intervention has been explained in details.

For more information regarding this manual, refer to the following link –
<http://cpheea.gov.in/cms/manual-on-sewerage-and-sewage-treatment.php>

2.12 SOP for cleaning of sewer and septic tank -

The standard procedures for cleaning of sewer and septic tanks have been prescribed in the year 2018 by CPHEEO, Ministry of Housing and Urban Affairs, Government of India. These standard procedures are being referred in this book.

For more details regarding this SOP refer the following link –
<http://cpheea.gov.in/upload/5c0a062b23e94SOPforcleaningofSewersSepticTanks.pdf>

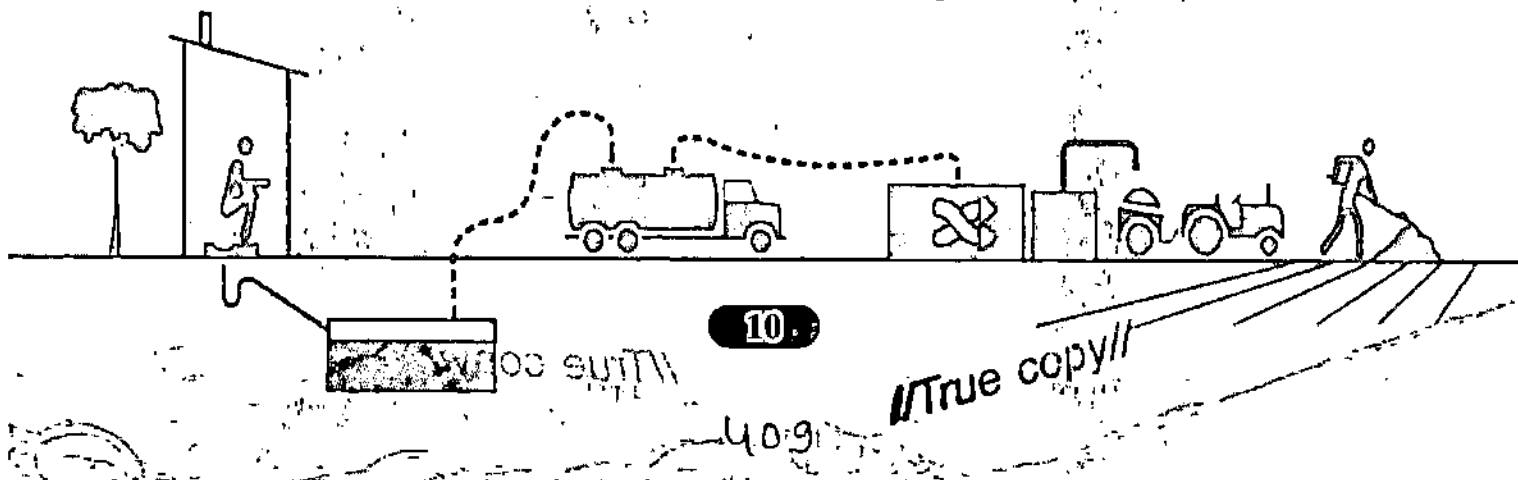

CHAPTER - 3

PROCEDURE FOR EMPTYING OF SEPTIC TANKS

3.1 Introduction:

It is necessary to empty the septic tanks regularly through systematic drainage and collection process to prevent environmental pollution. As per the guidelines of CPHEEO, it is necessary to empty the septic tank once in every 3 years. Although a septic tank can be cleaned once in a one or two years depending on the design criteria, however the cleaning interval should not exceed 3 years in any case.

Check whether your septic tank is constructed correctly or not -

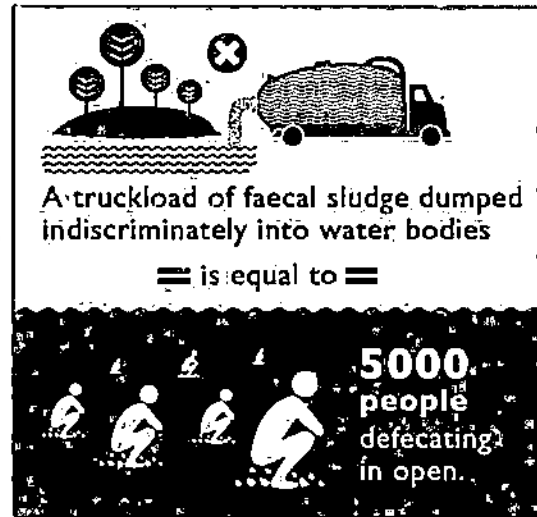

(Photo Credit: Malasur Campaign, Government of India)

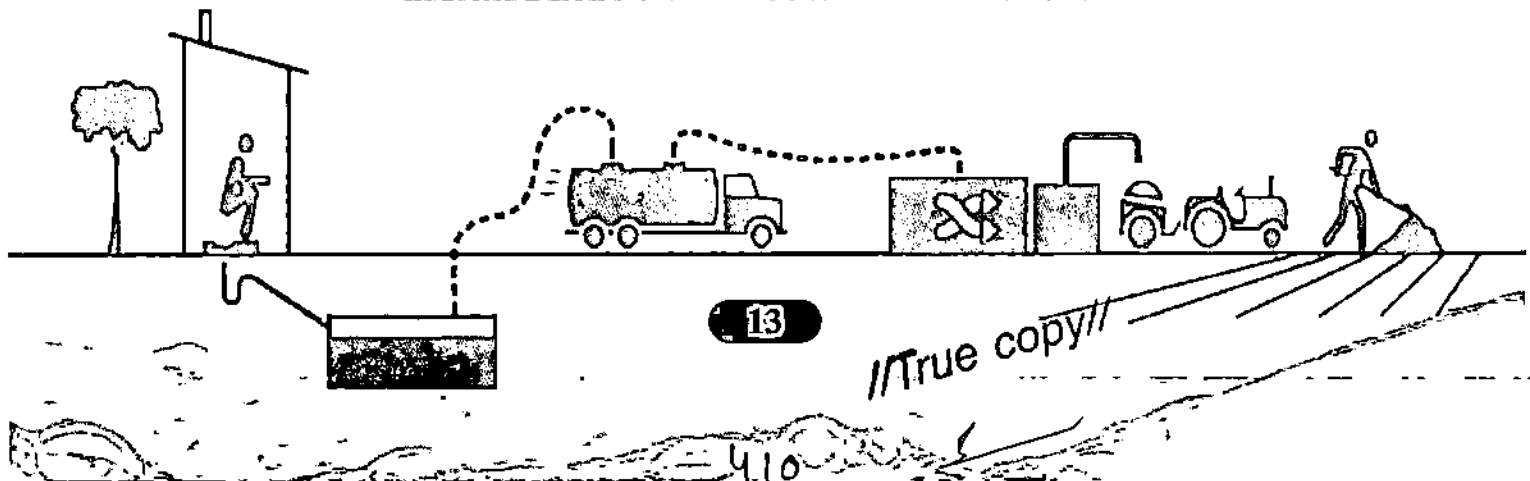
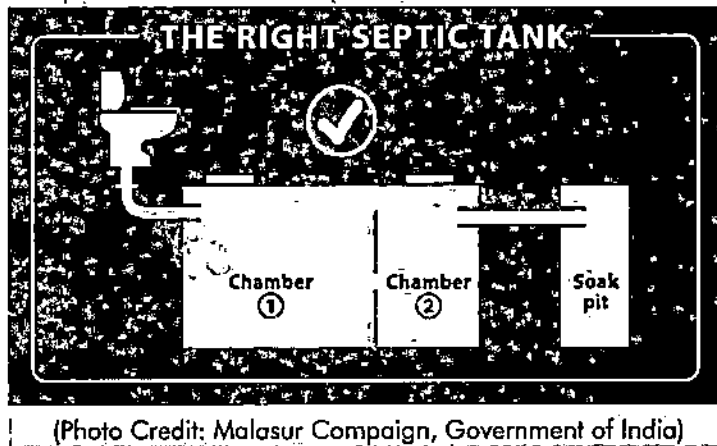

Further information related to the construction of septic tank is attached in Appendix – II.

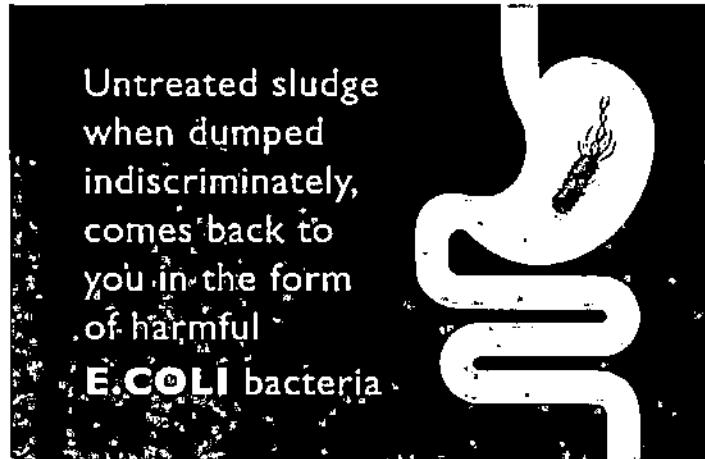

(Photo Credit: Malasur Campaign, Government of India)

3.2 For On demand desludging:

- (i) The city can set-up centralised call centre or toll-free number where citizens/households can call directly and request for a desludging service. These can be recorded digitally.

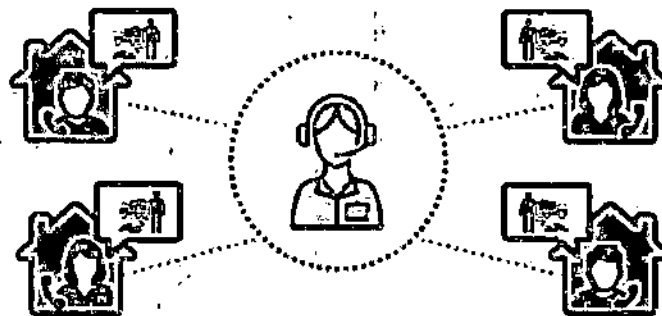

(Photo Credit – Centre for water and sanitation, CEPT University)

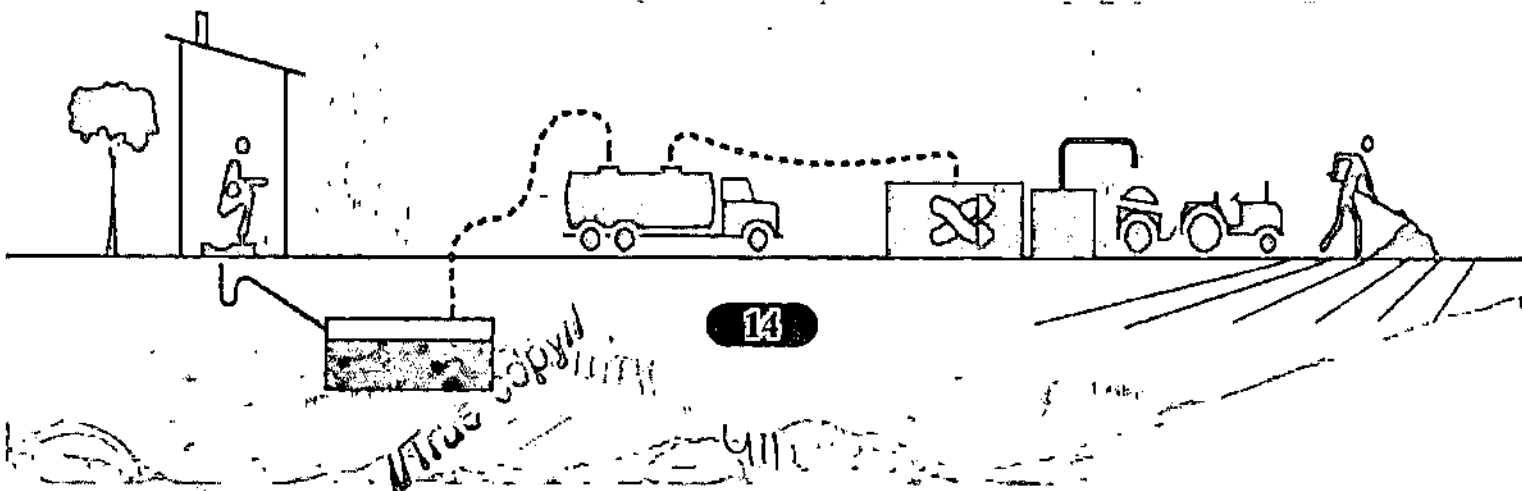

- (ii) From the emptying requests received for a particular day, an efficient route plan can be developed if there are many requests.
- (iii) The ULBs can either provide the emptying service through their own truck or pass on the request to registered/licensed private operator.
- (iv) If demand-based desludging is carried out by private operators in a city, they must either have a contract with the ULB for desludging activity or have a license issued by the ULB.

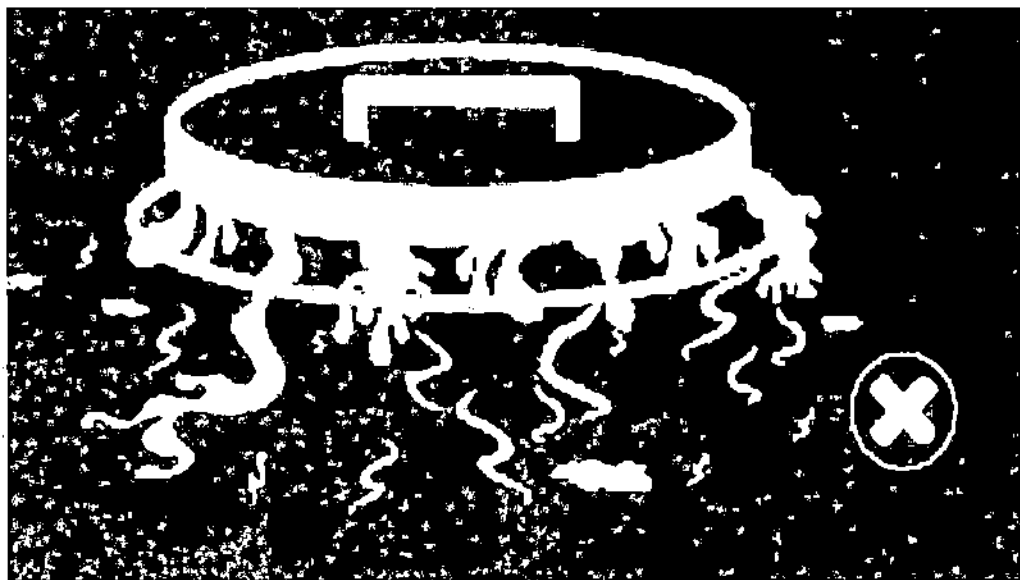

Desludge before your septic tank overflows

(Photo Credit: Malasur Campaign, Government of India)

3.3 For Scheduled Desludging:

- (i) For scheduling emptying operations, database of households is required. This database will help to ascertain distance of the nearest and farthest household from the FSTP. This database can be available from

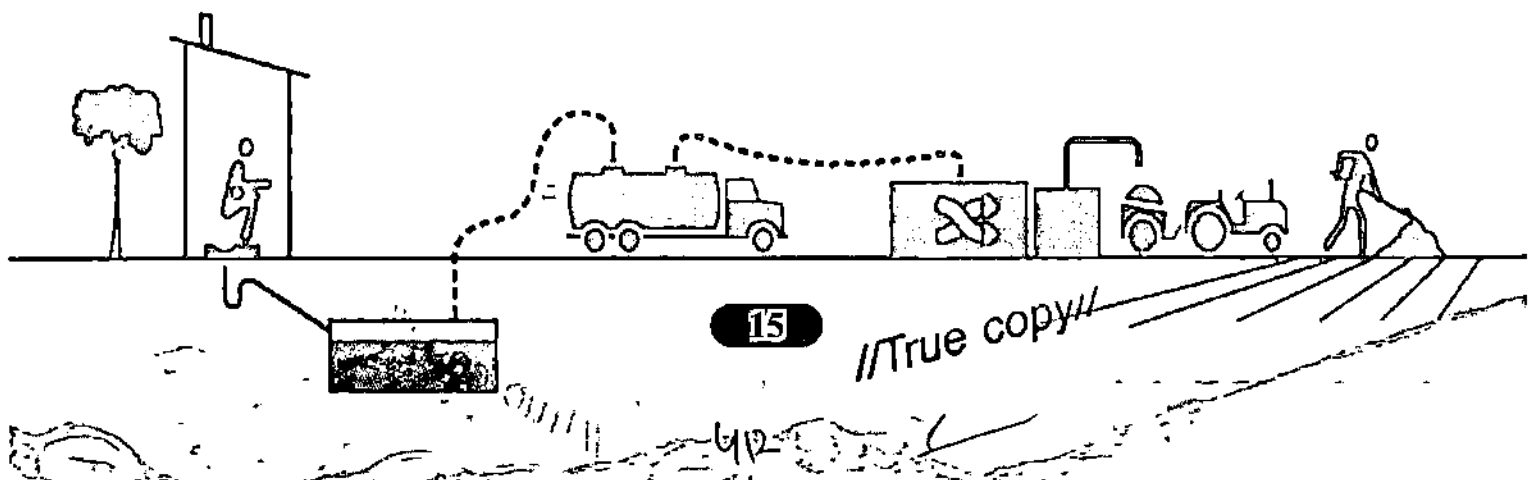

property tax database. A dedicated survey is not necessary if required data is available with the ULBs.

- (ii) if needed, the survey can be conducted through mobile based tool like Sanitab. Sample questionnaire is attached in Annexure-I
- (iii) Based on the information on total number of septic tanks to be emptied, requirement of emptying trucks of various capacity (if needed) must be decided.
- (iv) The total cost of operations, both capital cost and operating cost, can be worked out for desludging operations.
- (v) Route planning should be prepared in consultation with the sanitary department officials. Once the route plan is finalized, the IEC activities and outreach to communities can begin before desludging operation is initiated.
- (vi) A supervisor should be appointed by the service provider for field management. He/she will be in-charge to manage the entire scheduled desludging services. The roles and responsibility of each individual involved in this practice is available in Annexure-1
- (vii) The supervisor should send bulk SMSs, two days prior to the start of the desludging process as per the route plan, to household whose desludging is scheduled. The SMS informs households about the day and time of arrival of the vehicle at their property.
- (viii) For all scheduled households, the supervisor should send their team member one day prior on site. This is especially important for households who have not read the SMS on their mobile phones. The site visit will help in identifying exact location of septic tank.
- (ix) The house occupant must be asked to keep the covers of the septic tank open before the team arrives for desludging. The service provider can support this by providing a mason for opening the cover of septic tanks prior to desludging activity.

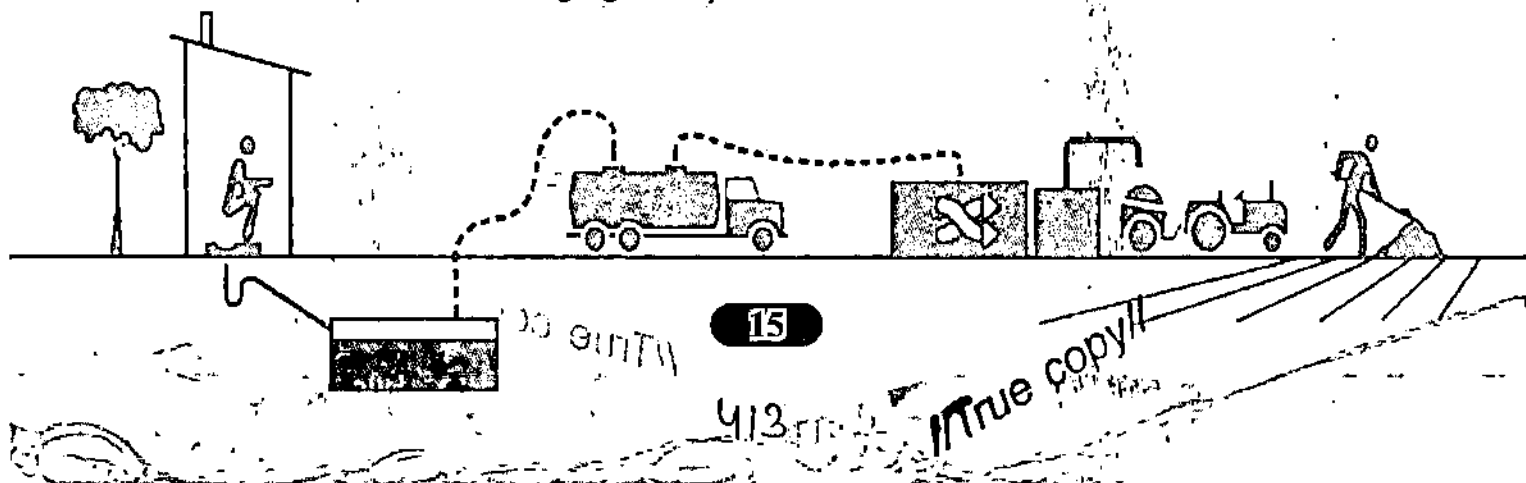

- (x) The owner/moson must open the lid of the machine hole and allow release of the gases present inside the septic tank for at least 10 to 15 minutes and make sure no one is close to the septic tank during this time. The helper must not lean over or crouch down at the tank opening during this operation
- (xi) In case the house occupant is not available on the scheduled day, their emptying should be rescheduled for the next day or the day on which he/she is available and the route plan should be altered accordingly.



(Photo Credit: Municipal Corporation, Khandwa, Madhyapradesh)

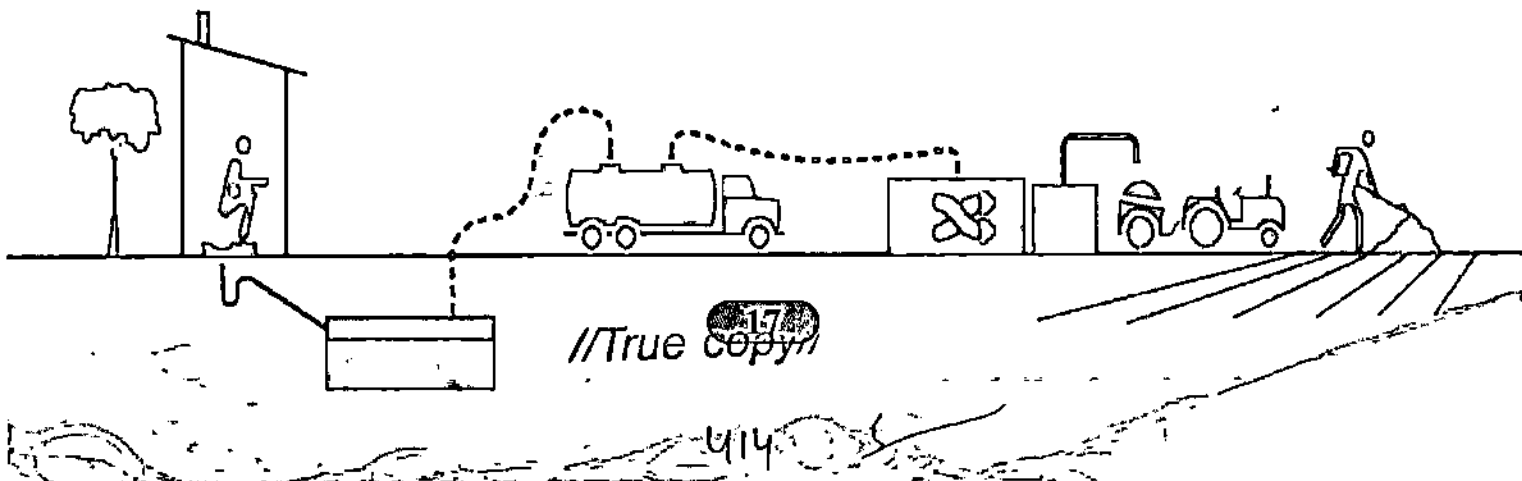

//True copy//

3.4 Activities and Precautions to be taken while Emptying the Septic Tank –

- (i) On the day of emptying the septic tank, the team should visit the identified families to confirm their availability and preparedness. It should also be ensured that the cover of the septic tank is open.
- (ii) The team should also do the inspection of the work site for possible hazards, such as evictions of people from the work site and identifying high groundwater, which can fill the tank when the tank is empty.
- (iii) A rapid survey should be carried out by the truck operator to identify the location of the septic tank cover so as to acquaint themselves with the approach road for laying the suction pipe.
- (iv) The truck operator should place the vacuum truck as close to the septic tank as possible. Generally, the distance of the truck should not exceed 25 meters and the height should not exceed 4 meters. If the length and height exceed the specified criteria, intermediate pumping may be required.
- (v) Before handling the sludge from the septic tank, the truck operator and helper should use Personal Protective Equipment (PPE Kit) to protect themselves from the potential hazards. Such as - protective clothing, goggles, helmet, gloves etc.
- (vi) The truck operator and his helper should bring the suction pipe up to the cover of the septic tank. If the distance from the vacuum truck to the septic tank is longer, use a longer pipe. In the absence of longer pipes, two or three pipes may be connected through metal couplings.
- (vii) If the septic tank lid is not opened by the mason, then open the mortar seal of the septic tank lid. Before and after emptying the tank, thoroughly inspect the cracks or damage in the tank and suggest to the residents for repairs.
- (viii) To empty the septic tank, connect the pipe to the tank or pit and secure the truck with wheel chocks.

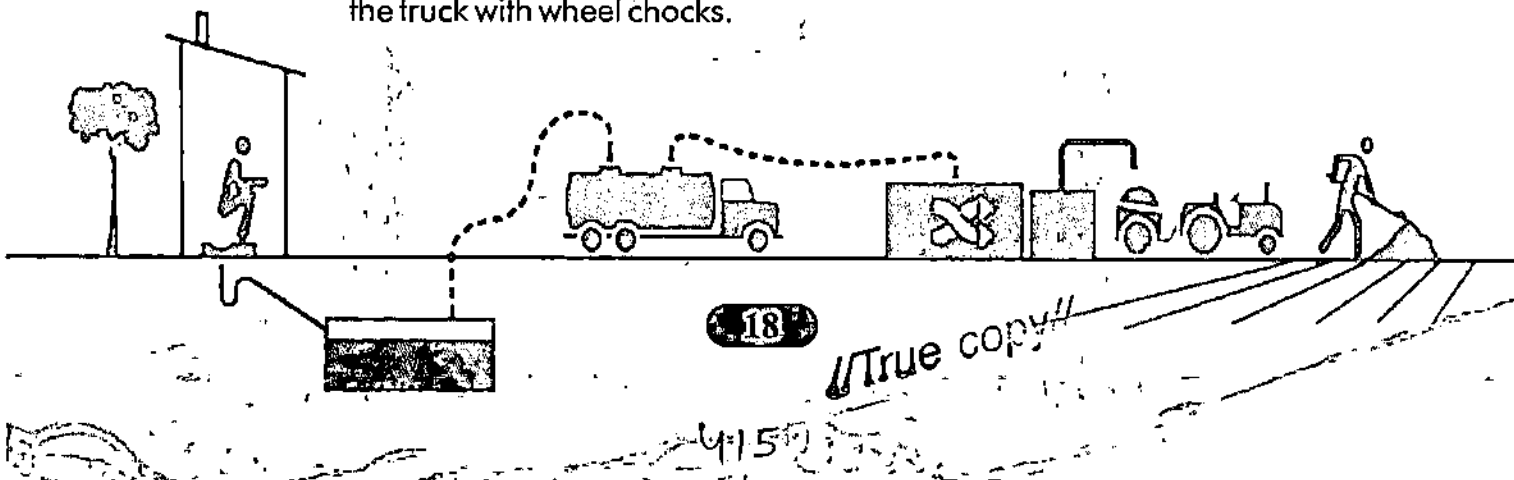

- (ix) It is necessary to ensure that the pipe is in good condition (No leaking in the Pipe) and the pipe connection is properly locked at the specified position in the vacuum.
- (x) Remove the septic tank opening or its cover to open the tank or pit.
- (xi) The thickness of the scum layer and the depth of the sludge layer in the tank (under the T pipe) should be measured by the truck operator/helper before starting the sludge removal. This will help in estimating the amount of septage to be removed from the septic tank. The truck operator/helper may record the height of the layer of scum and septage along with the final length of the hose pipe. A steel/PVC pipe (which already has markings) can also be submerged in the sludge to record the height.
- (xii) Start the vacuum equipment using Power Take off (PTO) from the transmission of the truck.
- (xiii) Increase the vacuum (suction pressure) from the nearest valve to the appropriate level by observing of the vacuum gauge. Then lowering the end of the pipe into the septic tank and open the inlet/outlet valve sufficiently so that the sludge is drawn out and reaches the tank.
- (xiv) To ensure that the vacuum pump is operating correctly, the truck operator should listen to its sound. If the sound is high or low, the pump may be blocked or jammed. In such situation the pump needs to be cleaned or repaired by a trained technician.
- (xv) During pump operation, the truck operator/helper shall use the end of the pipe to break the layer of sludge. A long hand spade can be used if required. Add water to make a slurry solution of the sludge.
- (xvi) Operators should leave at least a 2-inch layer of human excreta at the bottom of the septic tank to serve as seeding material.
- (xvii) After emptying the tank, close the lid of the tank and get it sealed with cement plaster by a mason.

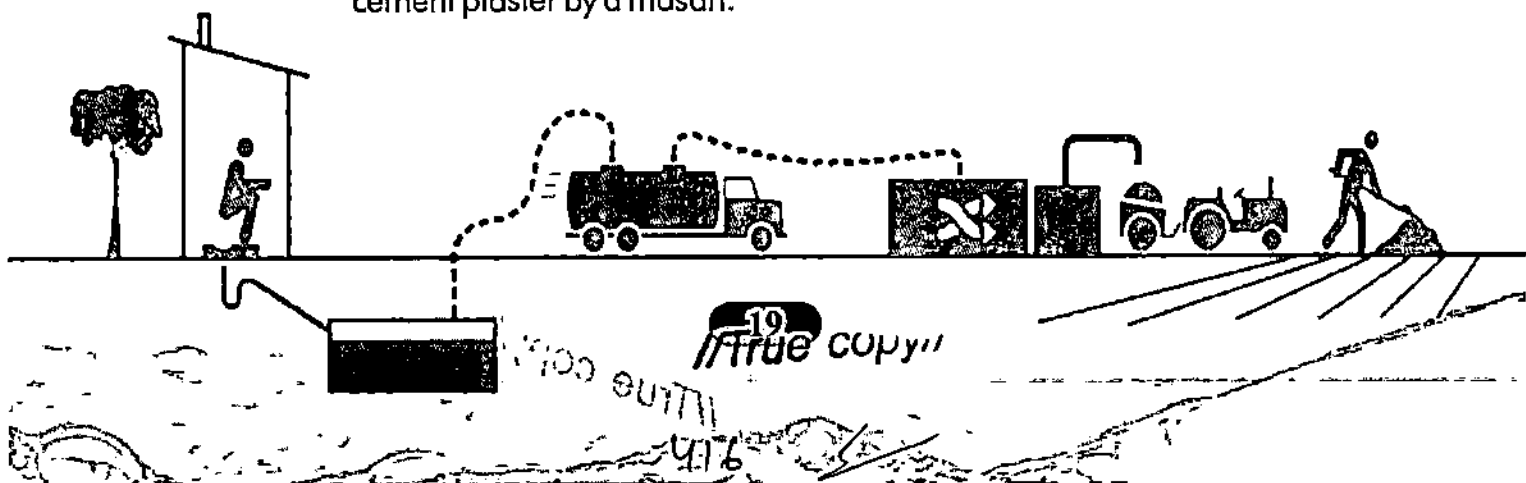

- (xviii) Ensure that the sludge does not contain high concentration of any non biodegradable material like oil, grease etc.

3.5 Activities and Precautions to be followed after Emptying the Septic Tank

- (i) After emptying the septic tank, the truck operator should detach the pipe by unscrewing it from the clamp fitting and relocating the pipe back to the truck's hose rack. Also, place all equipment in the hose rack.
- (ii) Clean up the spillage around the septic tank lid using an appropriate absorbent material. Spray 1% chlorine solution over the lid and around the septic tank.
- (iii) If the septic tank cover is broken, close it immediately with an easy-to-open cover.
- (iv) For daily reporting and documentation, the daily report (Annexure IV) to be filled by the Supervisor. In the daily report, the amount of sludge removed, the condition of the tank or the pit, any recommendations for repair and maintenance or any recommendations for the proper use of the system should be mentioned.
- (v) After emptying the septic tank, take the signature of the resident. Handover a copy of this report to the house owner. (Annexure V)
- (vi) The final report should also be entered in the computer of the urban body so that the database can be prepared and the next date of emptying the septic tank etc. can also be easily gathered.
- (vii) The driver should remove the wheel chokes from the wheel and take the truck to the nearest FSTP, as per the route plan. After disposal, the operator may proceed towards next house as per the route plan to empty its septic tank.
- (viii) The truck helper should thoroughly clean the vehicle at the end of the day to ensure that the next day's work starts on scheduled time.

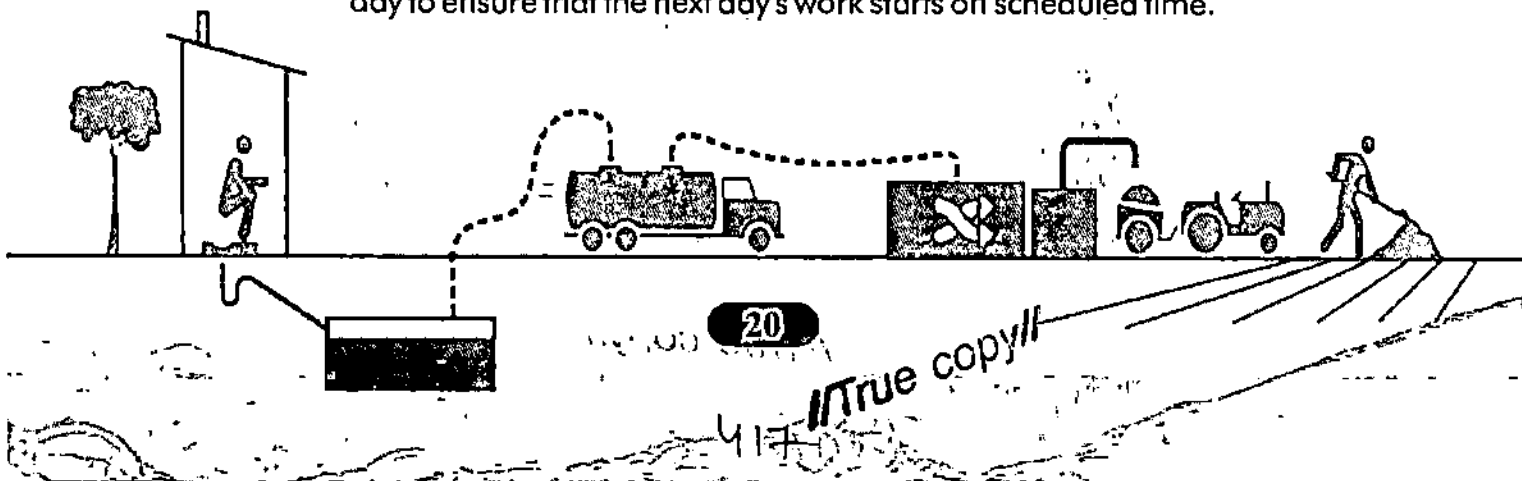

3.6 Activities to be carried out at FSTP Plant

- (i) Security guards at FSTP plant can register/digitally record the entry information of the truck through RFID (Radio Frequency Identification) system.
- (ii) The truck operator shall discharge the septage at the disposal site during the presence and with the permission of the FSTP operator.
- (iii) FSTP operators should use the following safety equipment's -
 - Face mask
 - Half face or full-face air purifier respirator with cartridge
 - Leather Gloves (heat resistant) / Rubber Gloves / Disposable Gloves as required during the work
 - Uniform / Apron
 - Safety Shoes / Gum Boots
 - Safety Helmet with Face Shield
 - Safety goggles
 - Ear plugs
- (iv) To reach the disposal site in the treatment plant premises the truck operator must follow the approved route displayed on the signage board.
- (v) To remove the septage from the truck, the truck operator shall park the truck at the receiving point only and keep the truck in neutral. Apply the parking brake and place wheel chocks on the wheels.
- (vi) After verifying the details and form submitted by the truck operator, the FSTP operator should allow the truck operator to connect the tanker of the truck to the sludge receiving pipe.
- VII. To monitor the quality of the sludge, the FSTP operator should check the pH/TDS and other parameters of the septage with a pH meter/TDS meter as per the monitoring protocol.

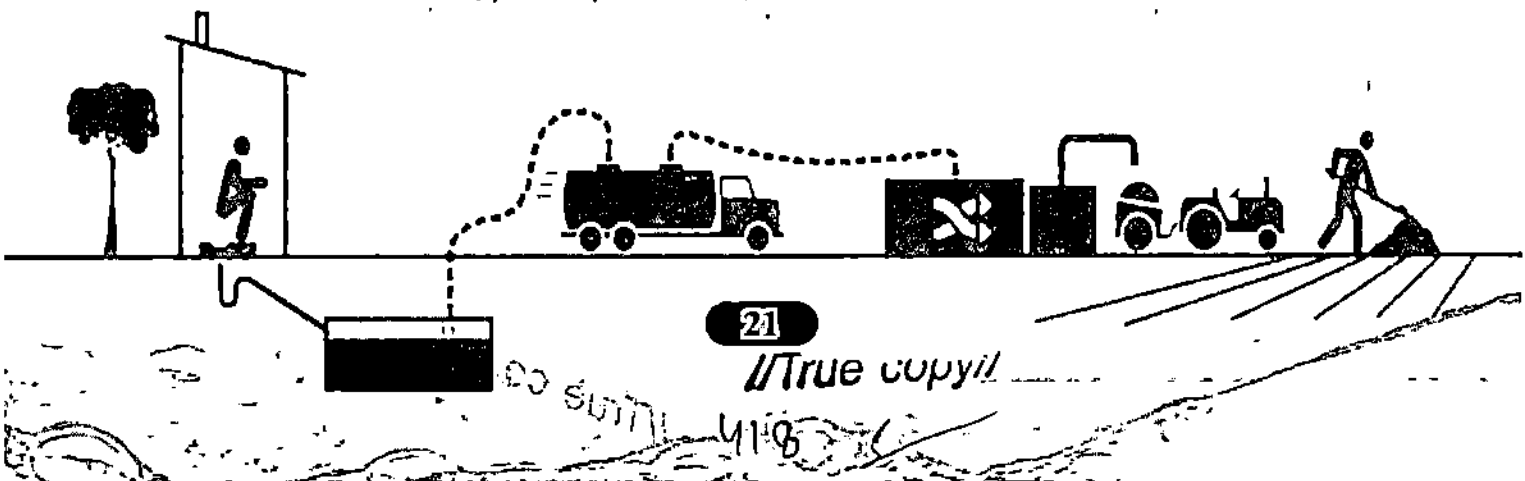

- (viii) Please ensure that both the FSTP operator and the truck operator are wearing the correct PPE kit (Uniform, Gloves, Mask, Gum Baat, Apran etc.).
- (ix) For the smooth flow of septage, the truck operator should ensure that the pipe couplings are properly connected between the truck and the receiving point.
- (x) At the signal of the FSTP operator, the truck operator should open the outlet valve of his tanker.
- (xi) FSTP operator should facilitate to clear out the septage from the truck. The truck operator should close the valve of the suction pipe when the truck operator is sure that all septage has been removed from the truck.
- (xii) The truck operator should obtain the signature of the FSTP operator after the septage is emptied at the FSTP plant. Give a copy of the report to the FSTP operator for their records (Annexure V) and proceed to the next house as per the route plan.

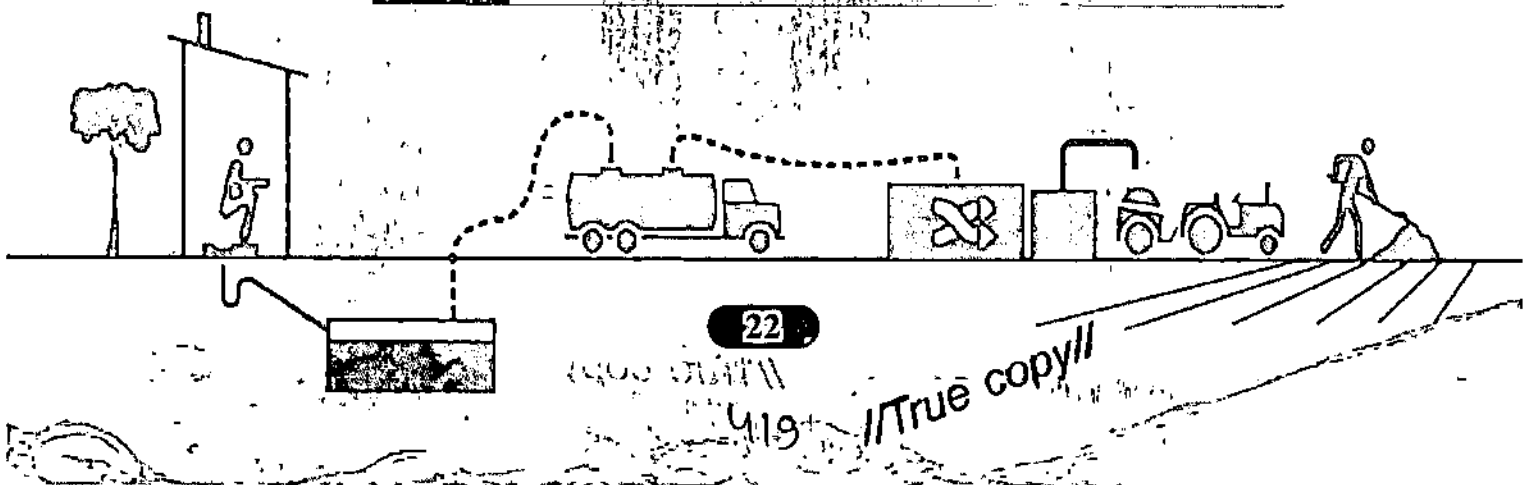
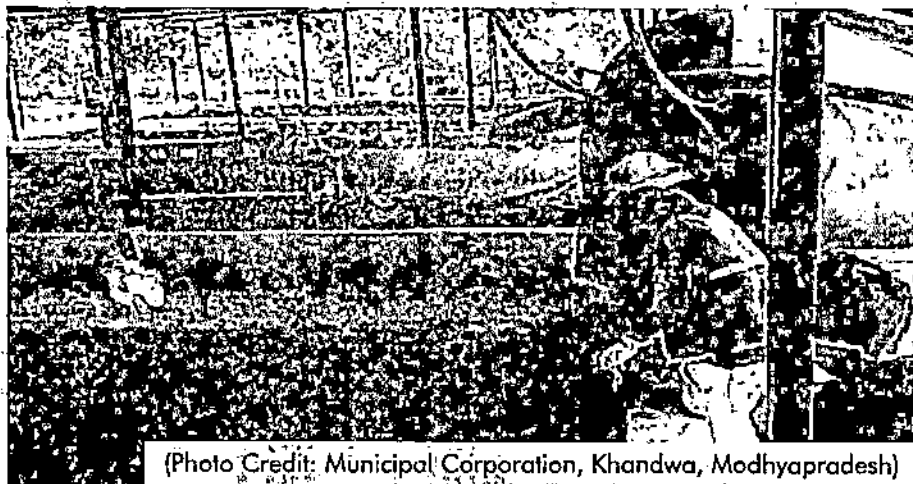

- (xiii) Immediately after removing the septage, wash the tonker of the truck thoroughly at the FSTP plant itself to remove the remaining sludge inside the tanker. Regular cleaning of the tanker can prevent the accumulation of sludge layer inside it. The waste generated during washing the tanker should be dumped again in the FSTP itself.

3.7 Important actions to improve the service of Septic Tank Cleaning –

- (i) Every morning the Supervisor should ensure that the sufficient fuel is available in the truck as per the route plan, so that the plan to empty the septic tank is not interrupted due to lack of fuel.
- (ii) Provision should be made for providing the Supervisor with some cash for minor repairs/ punctures repair/ breakdowns etc. in the vehicle so that the repair work does not get delayed.
- (iii) It has been observed that many a times the non-availability of masons leads to delay in opening the septic tank cover in some houses. A mason can accompany the truck operator, who could be paid off by the family. This will help to save the time of the truck operator. A letter may be issued by the local body to the Supervisor, mentioning the amount to be paid to the masons by the family.
- (iv) GPS tracking system can be installed on vehicles of civic and private service providers for effective monitoring. This will make it easier for the local body to track the movement, location of trucks. Also, it will help in ensuring that the septage collected is disposed of at FSTP only.
- (v) Monitoring form or mobile app can be developed to track and monitor de-sludging works like number of trips, quantity of septage removed etc. This will help in improving the service and plan for the future.

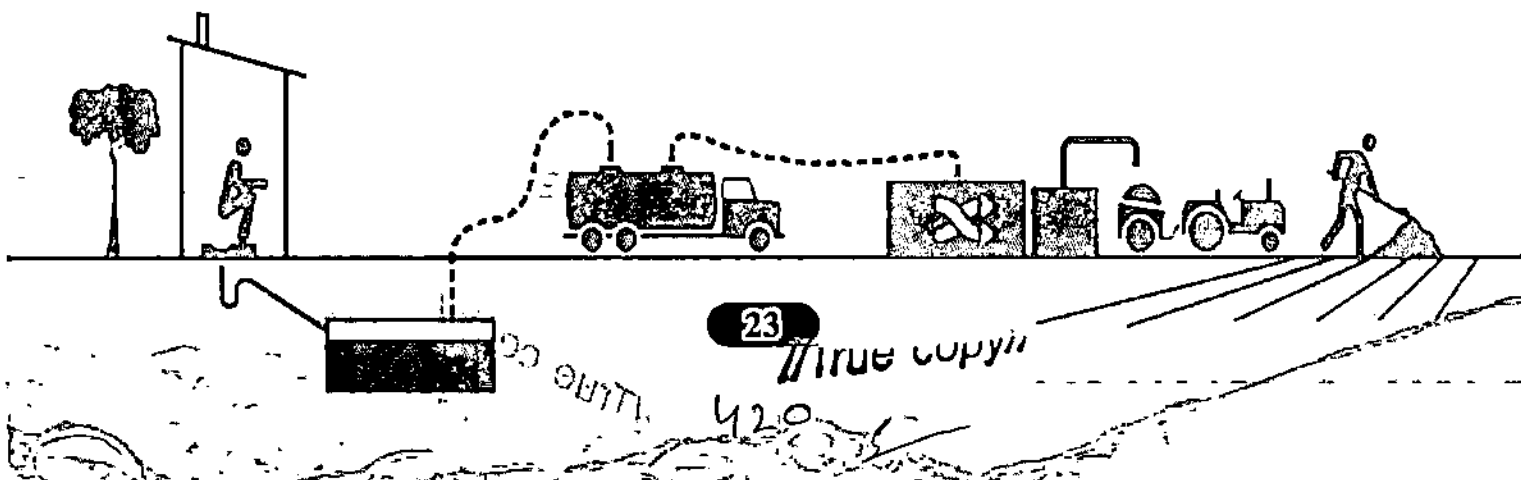

- (vi) Women can also be employed to motivate the community for regular emptying of septic tanks. These women can conveniently discuss the process of emptying the septic tank with the women of the household in the absence of male members of the household during the daytime.
- (vii) The Commissioner/CMO of the local body should hold a monthly meeting with the team members and Safai Mitra's. The agenda of this meeting should be to review the work done in the last month, discuss the challenges and improve the quality of service etc.
- (viii) For continuous improvement in the quality of services, quarterly training must be given to Safai Mitra's. Demonstrate the importance of using PPE in training. Precautions to be taken while removing sewer/septic tank/contaminated water/ sewage should be included. Rules and precautions to be followed while transporting sewage/contaminated water should be kept in it. Safe disposal of contaminated water/sewage at STP / FSTP plant, safe driving and following traffic rules etc. should be included in this.
- IX. Urban bodies should ensure that all Safai Mitra's should have regular medical examination and they have also been vaccinated (Corona, Typhoid, Tetanus etc.).

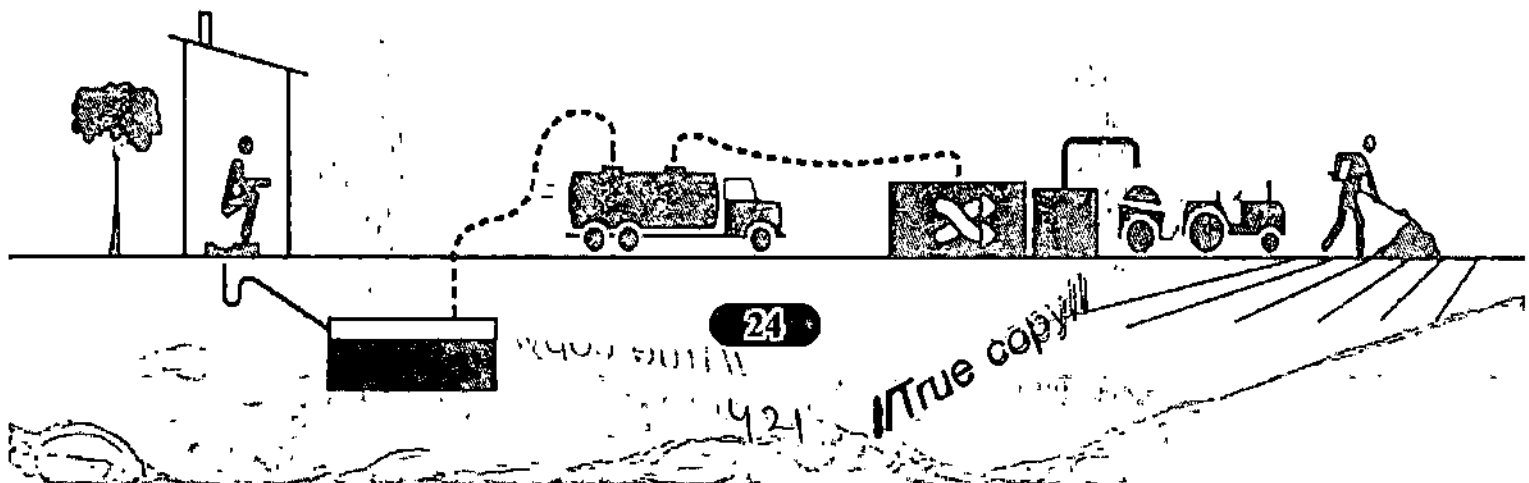

CHAPTER -4

CLEANING OF SEWERS

4.1 Introduction:

Mechanical cleaning of sewers is the most preferred method and shall be used to the extent possible. Manual entry for hazardous cleaning of sewers is completely banned as per the "Prohibition of Employment as Manual Scavengers and their Rehabilitation Rules, 2013 & Rules, 2013". For this purpose, sewer-cleaning using hydraulic or mechanical cleaning methods needs to be done on a scheduled basis to remove accumulated debris in the pipe such as sand, silt, grease, roots, and rocks.

4.2 Cleaning Frequency

The frequency of cleaning of sewers is based on the prevailing local conditions and determined through field inspections & complaints received from the residents of the area. However, it is desirable to clean the sewer at least once in every 6 months, ideally once just before monsoon season.

4.3 Procedures for Cleaning of Sewers Mechanical Procedure

Step 1: Reaching the site

- i. Selection of prospective employees for the sewer cleaning should consider the duties they will be expected to perform.
- ii. The complete hazard involved in the cleaning activity should be explained clearly to the employees by the supervisor and should get their consent in written before starting cleaning activities.
- iii. A supervisor along with adequate machinery and staff shall reach the

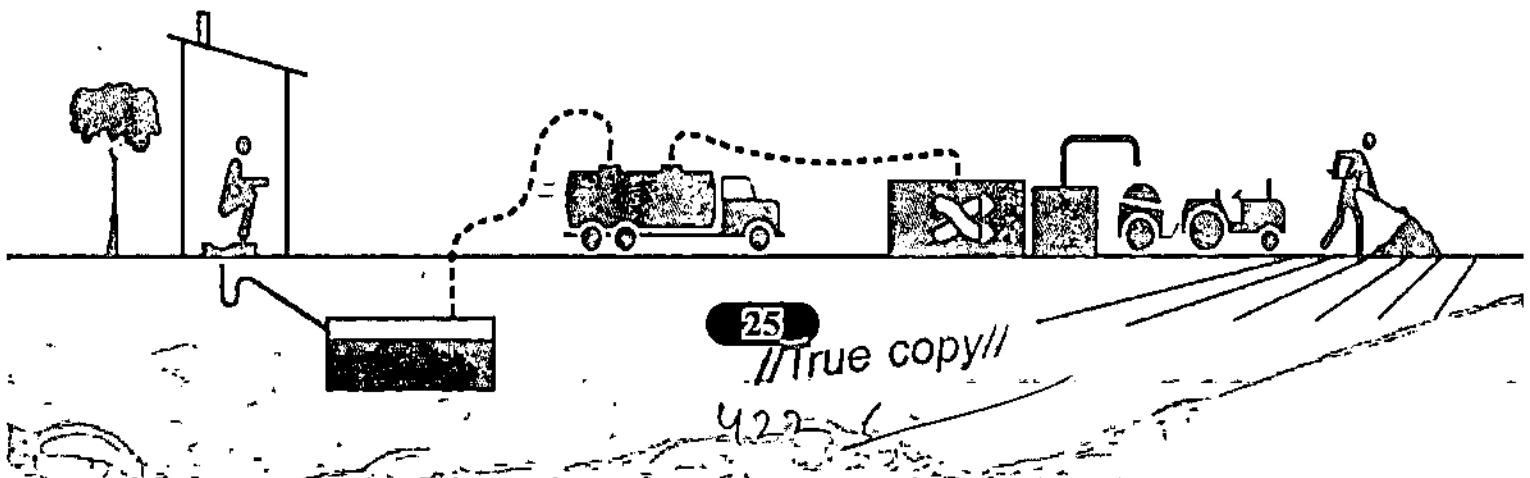

- designated site, preferably during lean period of sewage flow in sewers.
- iv. The supervisor shall have the names, address and emergency contact information of the staff involved in cleaning the sewers.
- v. Appropriate protective gears and safety devices shall be worn by the staff before beginning the work of cleaning the sewers.

Step 2: Identification and isolation of the area

- i. identify the stretch to be cleaned and identify the machine holes associated with the stretch.
- ii. Barricade the area where cleaning is to be carried out.
- iii. A flag man shall be stationed at least 15m ahead of the site and should be visible to incoming traffic for at least 150m.
- iv. Cones (like the one used by police) shall be placed on the road.

Step 3: Verify the presence of any gases or other hindrances

- i. Ventilate the sewer line by opening 2-3 machine holes on both sides of the working stretch far at least 1 hour prior to start of the work to ensure escape of toxic gases; The worker opening the machine hole must not bend down into the opened machine hole and this may cause his getting overcome by Hydrogen Sulfide and even tripping into the machine hole.
- ii. Use gas monitor, detector lamp, wet acetate paper or gas detector masks to detect any residues of poisonous gases like hydrogen sulfide, carbon monoxide, methane, and gasoline vapors.
- iii. Insert a long pole with lead acetate paper which will convert to black color in the presence of hydrogen sulfide. The person shall not try to insert the paper by hand into the machine hole.
- iv. If gases are detected, extend waiting period to allow residual gases to escape and to avoid the chance of explosion, in case. Repeat the procedure many times for checking the escape of toxic gases.

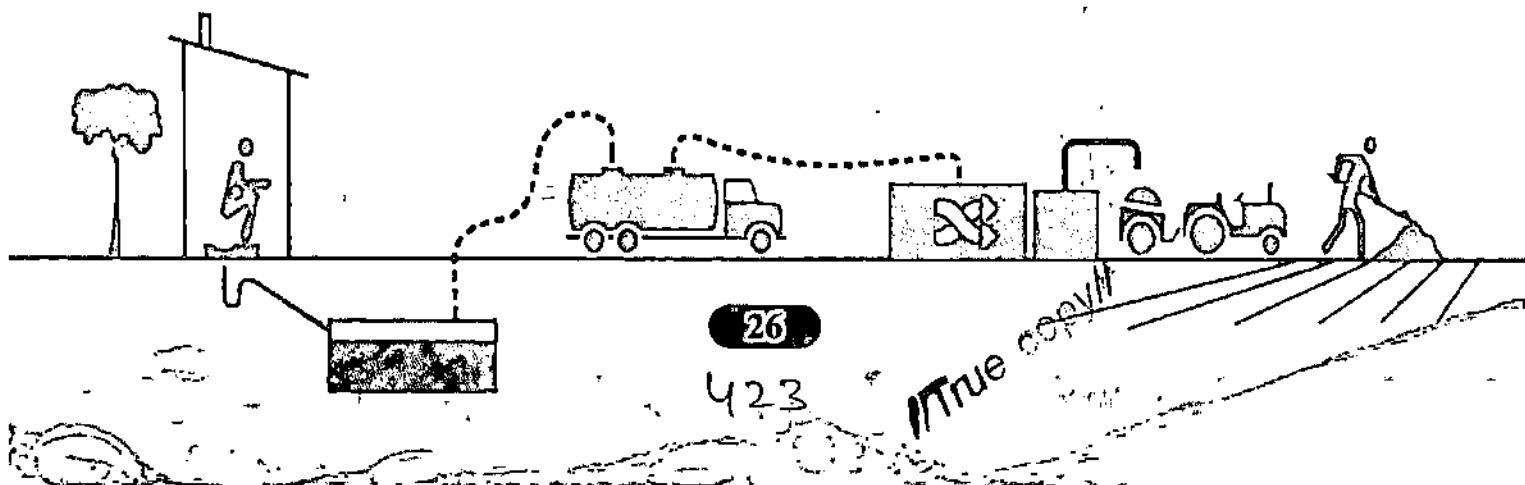

- v. Before the start of the cleaning operation, employees shall check for hindrances that may delay the cleaning process.
- vi. Dummy covers with welded fabric or wire net shall be used to cover the machine hole, if required. However, care should be taken to ensure that the cover is strong enough to hold a man's weight.

Step 4: Removal of silt/wax - Mechanical Process

- i. Appropriate machines, at least to the extent specified in this SOP are to be used to remove the silt/wax.
- ii. The operating procedures of these machines shall be strictly followed for cleaning.
- iii. The machine hole cover shall be closed tightly after cleaning.



Step 5: Leaving from the site

- i. All the equipment/machineries along with the protective gears and safety devices that had any direct contact with the sewage shall be cleaned (Photo Credit: Municipal Corporation, Khandwa, M.P.) per the cleaning procedure specified by the manufacturer.
- ii. All the equipment, safety gears, barricades etc shall be removed from the working area and the crew shall move to the base or to the next site.
- iii. The entire operation shall be monitored and documented by the supervisor.

4.4 Manual Cleaning Procedure

Manual cleaning of sewers is totally prohibited, in special situations (where

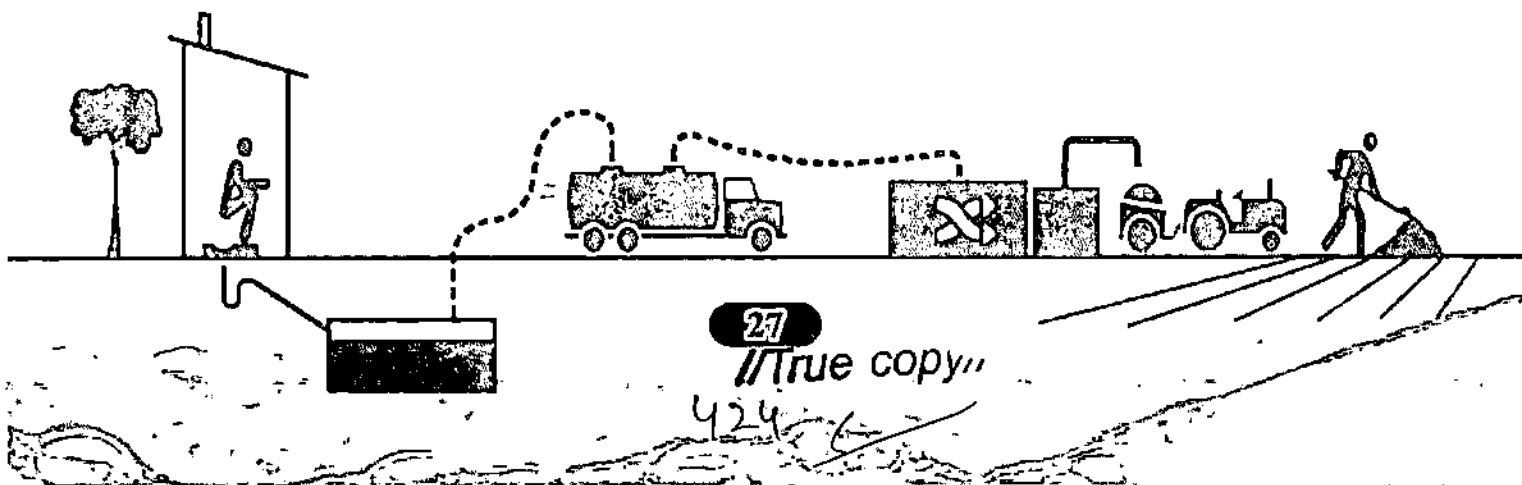

27
 //True copy//
 424

cleaning of sewers/septic tanks/machine holes are not possible with machines, and it is compulsory do manual cleaning) the Commissioner/CMO of the urban local body must inform to the District Emergency Response Unit (ERSU) in writing. The ERSU will employ specially trained team with protective equipment's to do manual cleaning of septic tanks/sewers/machine holes in such case.

For more information on manual cleaning of sewers/machine holes please refer to the ERSU guidelines issues by Government of India. Please click the link below to download the guidelines:

https://niua.org/scbp/sites/default/files/Advisory_on_Emergency_Response_Sanitation_Unit_0.pdf

Step 1: Reaching the site

- i. Selection of prospective employees for sewer cleaning should consider the duties they will be expected to perform.
- ii. The complete hazard involved in the cleaning activity should be explained clearly to the employees by the supervisor and should get their consent in written before to start cleaning activities.
- iii. A supervisor along with adequate machinery and staff shall reach the designated site, preferably during lean period of sewage flow in sewers.
- iv. The supervisor shall have the names, address and emergency contact information of the staff involved in cleaning the sewers.

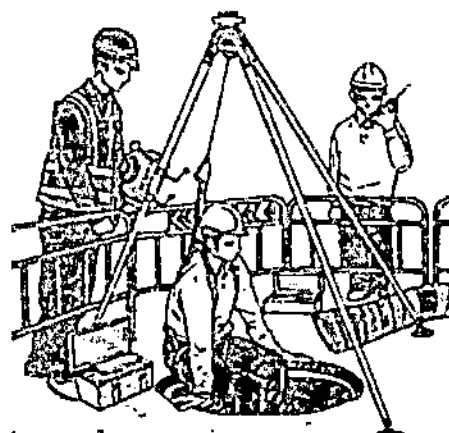

(Photo Credit: MOUHA, Govt. of India)

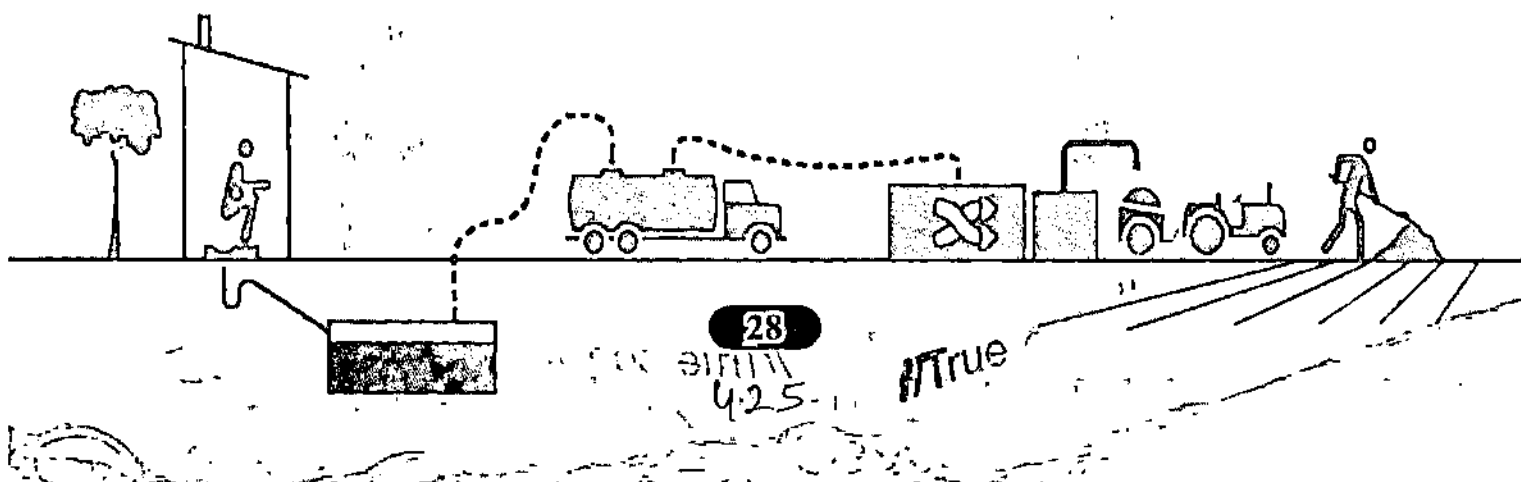

- v. Appropriate protective gears and safety devices shall be worn by the staff before the start of work on cleaning the sewers. Please see the check list on annexure VI and VII.

Step 2: identification and isolation of the area

- i. Identify the stretch to be cleaned and identify the machine holes associated with the stretch.
- ii. Barricade the area where cleaning is to be carried out.
- iii. A flag man shall be stationed at least 15 m ahead of the site and should be visible to incoming traffic for at least 150 m.
- iv. Cones (like the one used by police) shall be placed on the road.

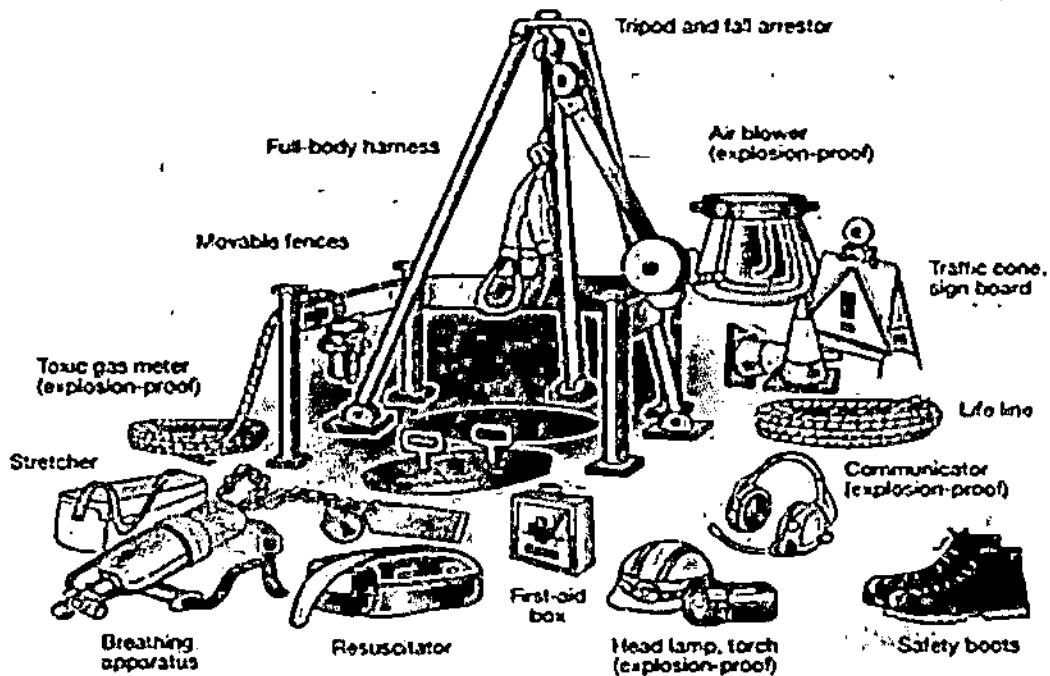

(Photo Credit: CPHEEO, Govt. of India)

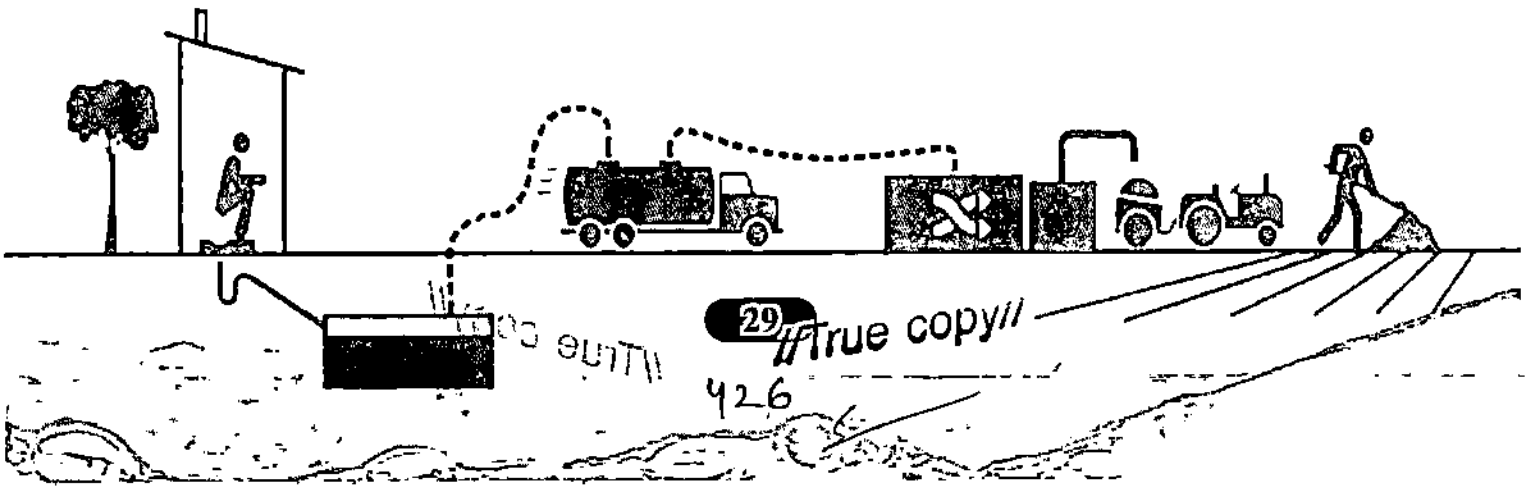

Step 3: Verify the presence of any gases or other hindrances

- i. Ventilate the sewer line by opening 2-3 machine holes on both sides of the working stretch for at least 1 hour before to start the work to ensure escape of toxic gases.
- ii. The labor opening the machine hole must not bend down into the opened machine hole and this may cause his getting overcome by Hydrogen Sulfide and even tripping into the machine hole.
- iii. Use gas monitor, detector lamp, wet acetate paper or gas detector masks to detect any residues of poisonous gases like hydrogen sulfide, carbon monoxide, methone, and gasoline vapors.
- iv. insert a long pole with lead acetate paper which will convert to black. The person shall not try to insert the paper by hand into the machine hole.

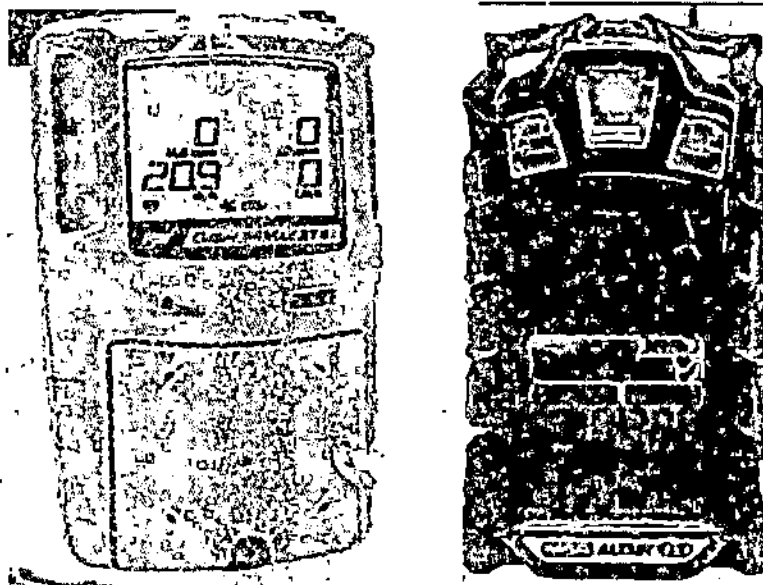

(Photo Credit: CPHEEO, Govt. of India)

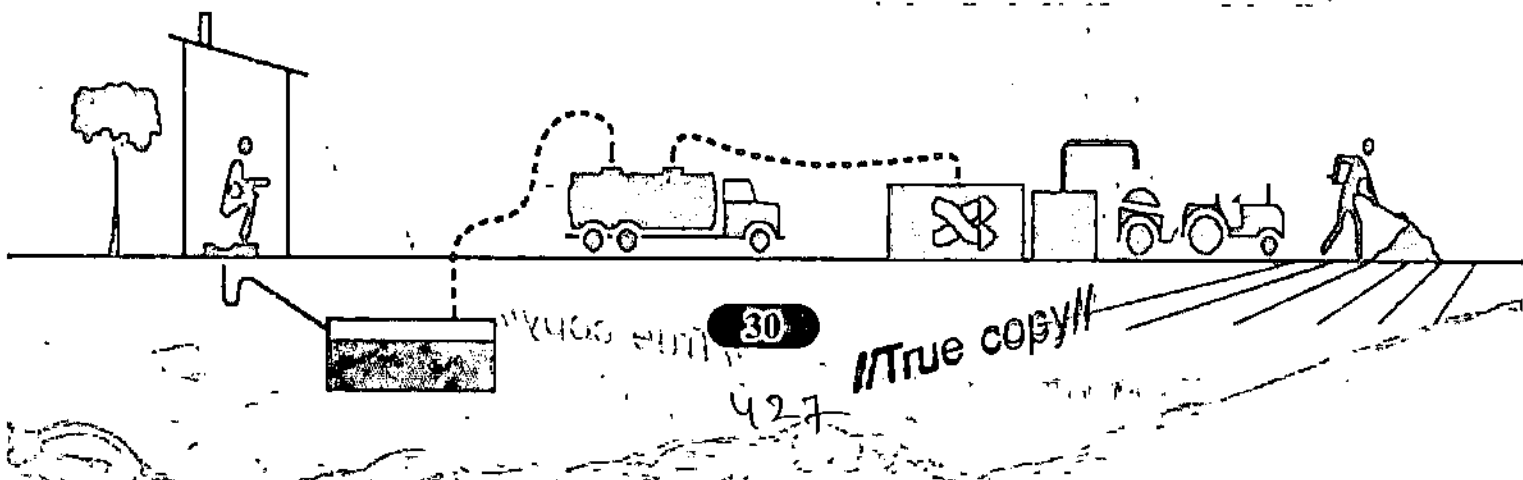

- v. if gases are detected, extend waiting period to allow residual gases to escape and to avoid the chance of casualty, in case. Repeat the procedure many times for checking the escape of toxic gases.
- vi. Before to start the cleaning operation, employees shall check for hindrances that may delay the cleaning process.
- vii. Dummy covers with welded fabric or wire net shall be used to cover the machine hole, if required.



Self-contained Breathing Apparatus (SCBA)

(Photo Credit: CPHEEO, Govt. of India)

Step 4: Removal of silt/clogs/rocks

- i. Identify and close off or re-route the inlet sewage of the identified stretch, if possible.
- ii. Check the oxygen level in the machine hole. If it is less than 19.5% or greater than 21% at any of the three levels (i.e., bottom, middle and top), the staffs (is it staffs or personnel) shall not be allowed to enter the machine hole.
- iii. Air should be supplied into the machine holes or to make provision of ventilation to achieve the desired oxygen level.
- iv. The staff shall wear full

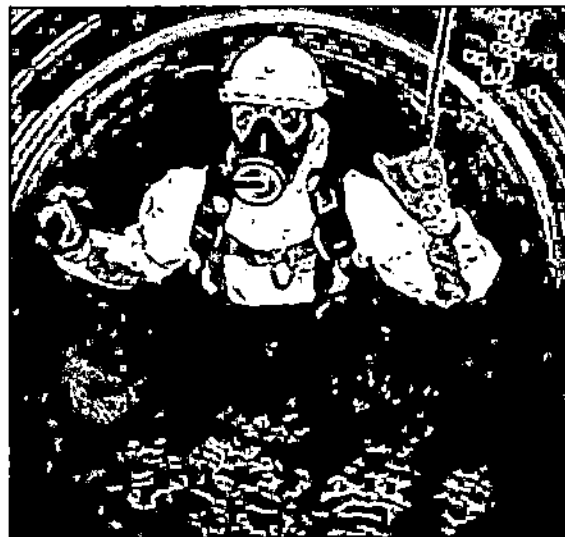

(Photo Credit: CPHEEO, Govt. of India)

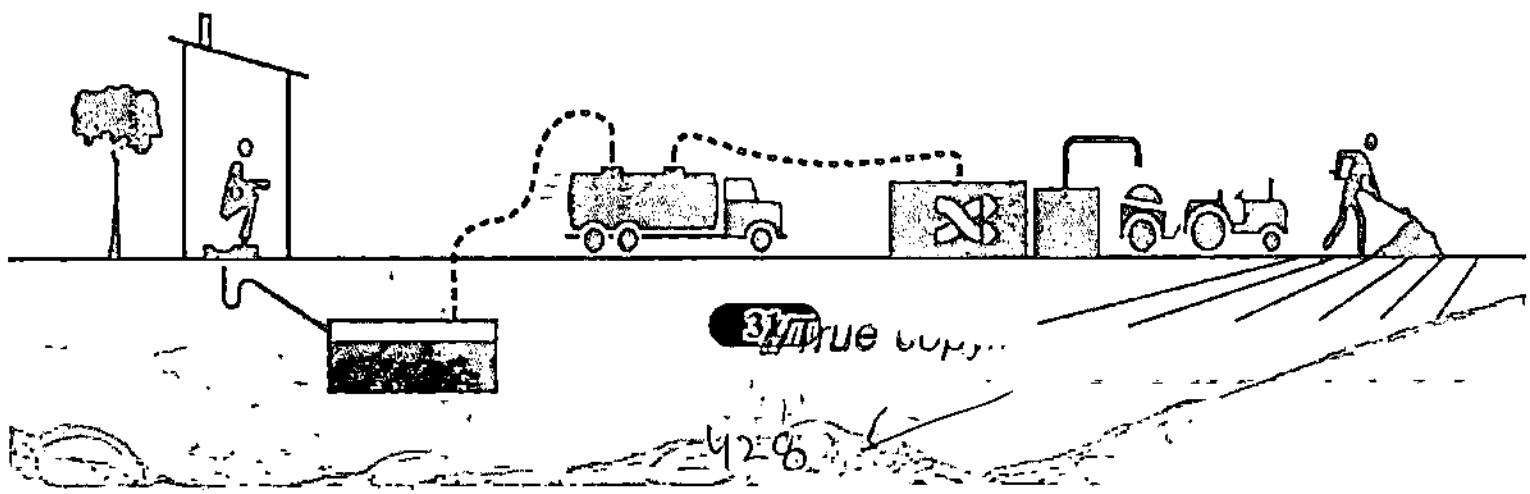

3/1/2006
4/2/06

- bodysuit if entering machine holes of more than 5 ft. depth or partial fishing wade suits if entering machine holes of less than 5 ft. depth.
- v. All the staffs entering the sewer shall wear helmet attached with head lamp.
 - vi. The staff entering the sewer shall preferably wear full-face mask having escape breathing apparatus with at least 10-minute air supply along with other appropriate protective gears and safety devices.
 - vii. Safety belt shall be fastened tightly onto their suit.
 - viii. The staff shall have extra flashlights and communication devices such as two-way radios.
 - ix. The staff shall check for the stability of the machine hole walls visually and the strength of the rope ladder and descend into the machine hole carefully after getting the permission of the supervisor.
 - x. The persons entering the machine hole shall be monitored by CCTV cameras or any other suitable mechanism at the ground.
 - xi. Clogs/silt/rocks shall be removed by using appropriate machineries/equipment and brought up to ground level and then shall be suitably disposed at the designated areas.
 - xii. Pull the staff out of the machine hole after completion of cleaning activities.
 - xiii. Machine hole lid shall be closed tightly after cleaning.
 - xiv. At a stretch, a duration not exceeding 90 minutes shall be taken for cleaning the sewers and a mandatory interval of 30-minute shall be given to the staff involved in cleaning between two intervals.

Step 5: Leaving from the site

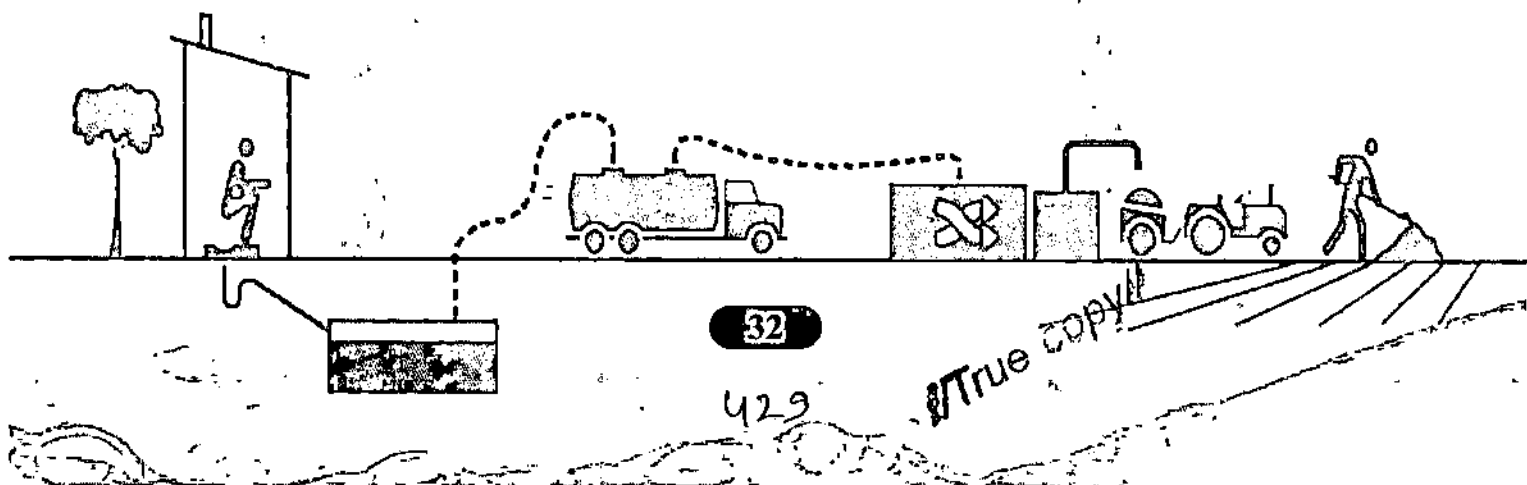

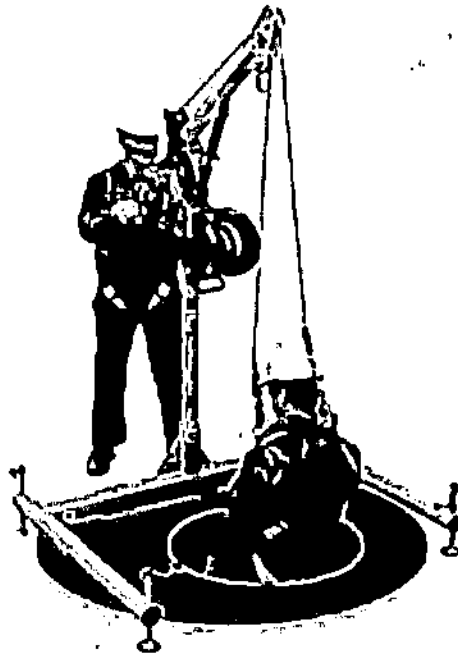

(Photo Credit: CPHEEO, Govt. of India)

- i. All the equipment/machineries along with the protective gears and safety devices that had any direct contact with the sewage shall be cleaned properly.
- ii. All the equipment, safety gears, barricades etc shall be removed from the working area and the crew shall move to the base or to the next site.
- iii. The entire operation shall be monitored and documented by the supervisor.

4.5 Type Of Inspections and Examinations Of Sewers

Inspection and examination are the techniques used to gather information to

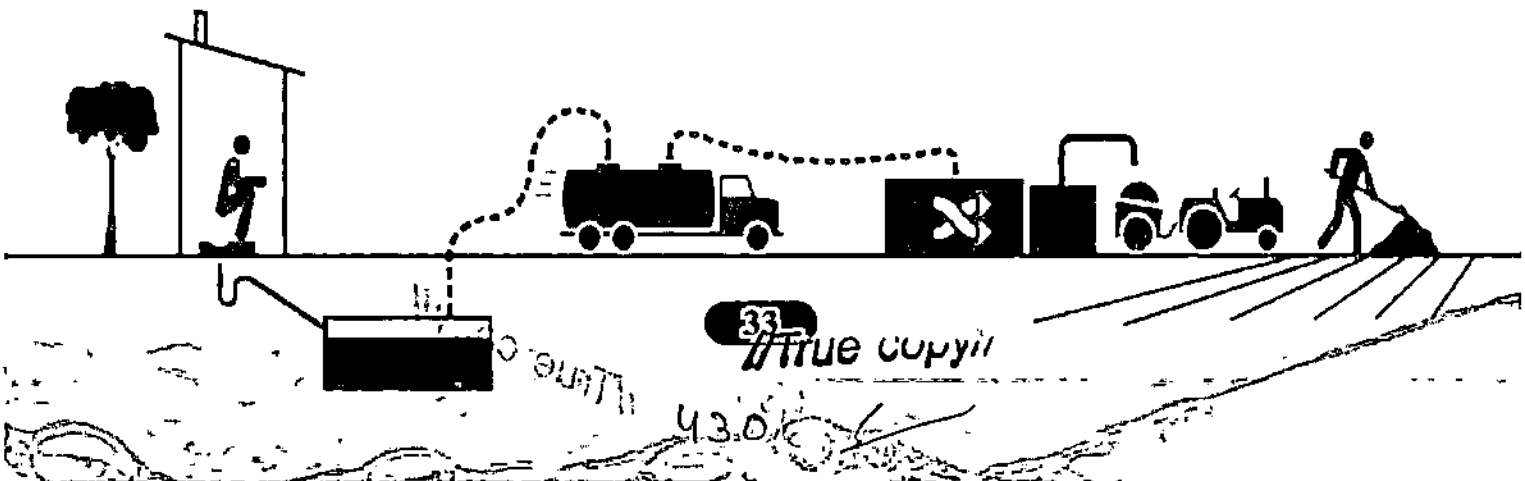

develop operation and maintenance programs to ensure that new and existing collection systems serve their intended purposes on a continuing basis. Inspection and testing are necessary to identify existing or potential problem areas in the collection system, evaluate the seriousness of detected problems, locate the position of problems, and provide clear, concise, and meaningful reports to supervisors regarding problems. There are two basic types of inspection and examination i.e., direct, and indirect described below:

4.5.1 Direct Method

Direct method is performed through direct visual inspection by the inspector who enters the manhole with proper safety gear as prescribed. This shall never be done once a sewer has been put into service.

4.5.2 Indirect Method

CPHEEO's Manual on Sewerage and Sewage Treatment Systems, 2013 prescribes various methods of indirect inspection of sewer lines. Sewer system inspection technologies that are considered applicable to Indian conditions by the Manual are as follows:

4.5.2.1 Light and Mirror Method

Two successive manholes are opened and vented sufficiently for about an

No.	Technology	Applicability Sewer size	Sewer condition
1	Light and Mirror	Up to 300 mm	Empty
2	Closed Circuit Camera	Any Size	Empty
3	Sonar Systems	Any Size	Full Flowing

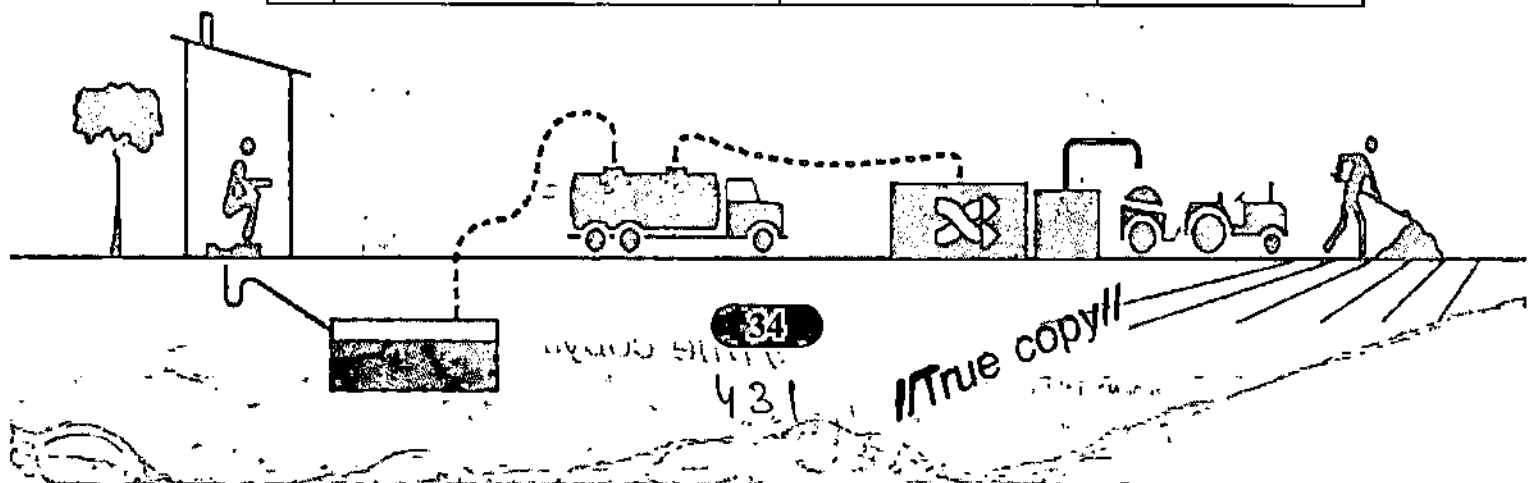

hour. Thereafter, a long hand-held mirror secured at 45 degrees to the handle is lowered into the bottom of the machine hole and a torch light is focused on the mirror from above so that the light beam is deflected by 90 degrees to travel horizontally through the sewer pipe and the light is seen in the opposite machine hole. This is easier at dusk. This can tell whether the bore of the pipe is choked or clear or laid straight.

4.5.2.2 Closed Conduit Camera Method

The close circuit camera is propelled through the sewer by a remote-controlled wired power supply from a van and travels through the sewer and relays the picture of the inside to a TV in the van. The CCTV inspection can be used for sewer lines as small as 100 mm. Above 900 mm diameter there are limitations due to lighting problems and camera line angles. The traction of the cameras is provided either by pulling winches, by pushing or self-traction. The former two are not used much at present. However, self-traction is suitable for use in sewers above 225 mm diameter.

4.5.2.3 Sonar System

The sonar system is similar. A robot is sent through the sewer, and it emits high

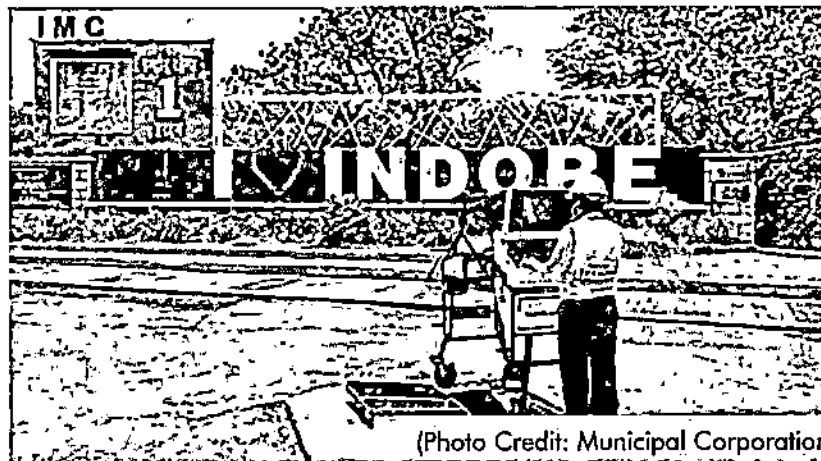

(Photo Credit: Municipal Corporation, Indore, M.P.)

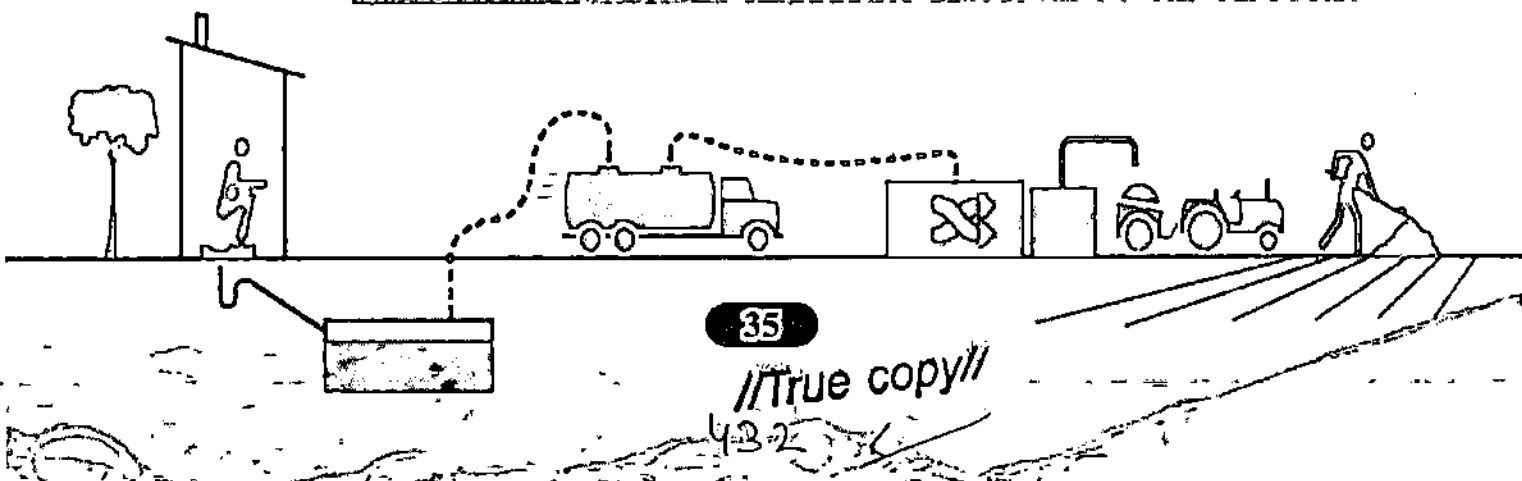

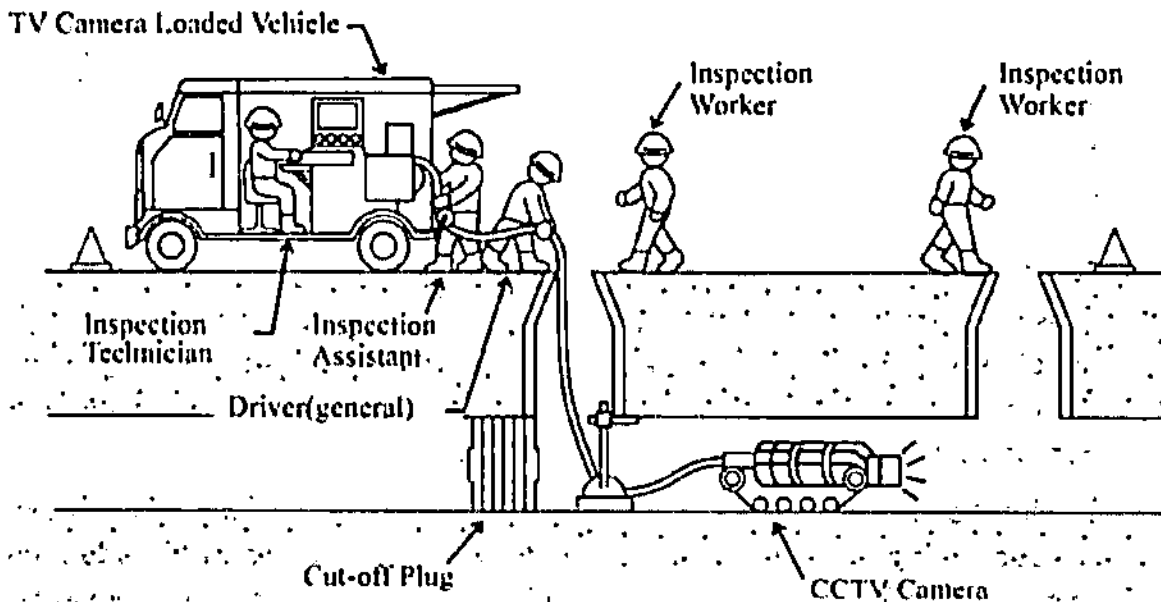

(Photo Credit: CPHEEO, Govt. of India)

frequency sound waves, which impinge on the pipe surfaces and returns to the emitter as a reflection. By knowing the material of construction of the sewer pipe walls, this can be programmed to verify the structural condition of the wall at the sewers.

4.6 Methods of Cleaning Sewers

Mechanical means of cleaning sewers is most preferred method and shall be employed wherever possible. Manual entry into the sewers shall be avoided as far as possible and shall be employed only in inevitable cases, that too with proper protective gears & other cleaning devices and ensuring observance of safety precautions.

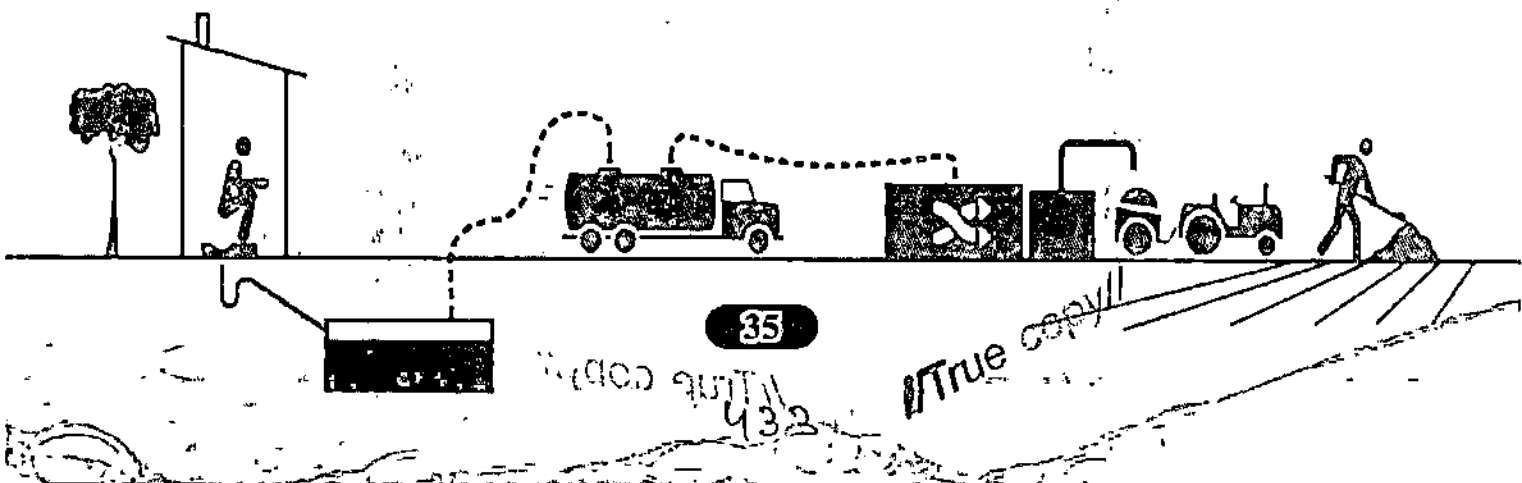

Most often de-silting machines and jetting/suction machines are employed by larger ULBs in the Country for cleaning their sewers. Various sewer cleaning methods are described in the CPHEEO Manual on Sewerage and Sewage Treatment Systems, 2013. Some of them are described below:

4.6.1 Manual Methods

4.6.1.1 Sectional Sewer Rods

These rods are used for cleaning small sewers. The sewer rods may be of light metal usually about one-meter-long at the end of which is a coupling, which remains intact in the sewer but can be easily disjoined in the machine hole. Sections of the rods are pushed down the sewer.

The front or the advancing end of the sewer rod is generally fitted with a brush, a rubber ring for cleaning or a cutting edge to cut and dislodge the obstructions. These rods are also useful to locate the obstruction from either machine hole in case a particular portion of the sewer must be exposed for attending to the problem.

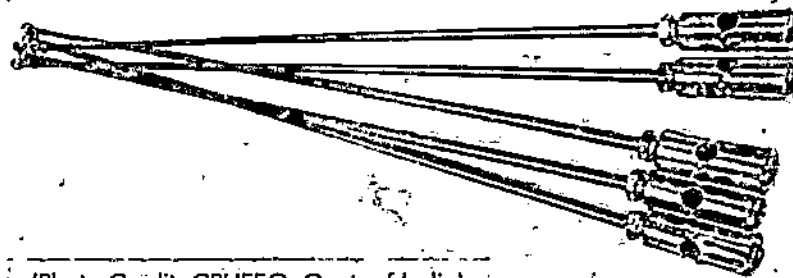

(Photo Credit: CPHEEO, Govt. of India)

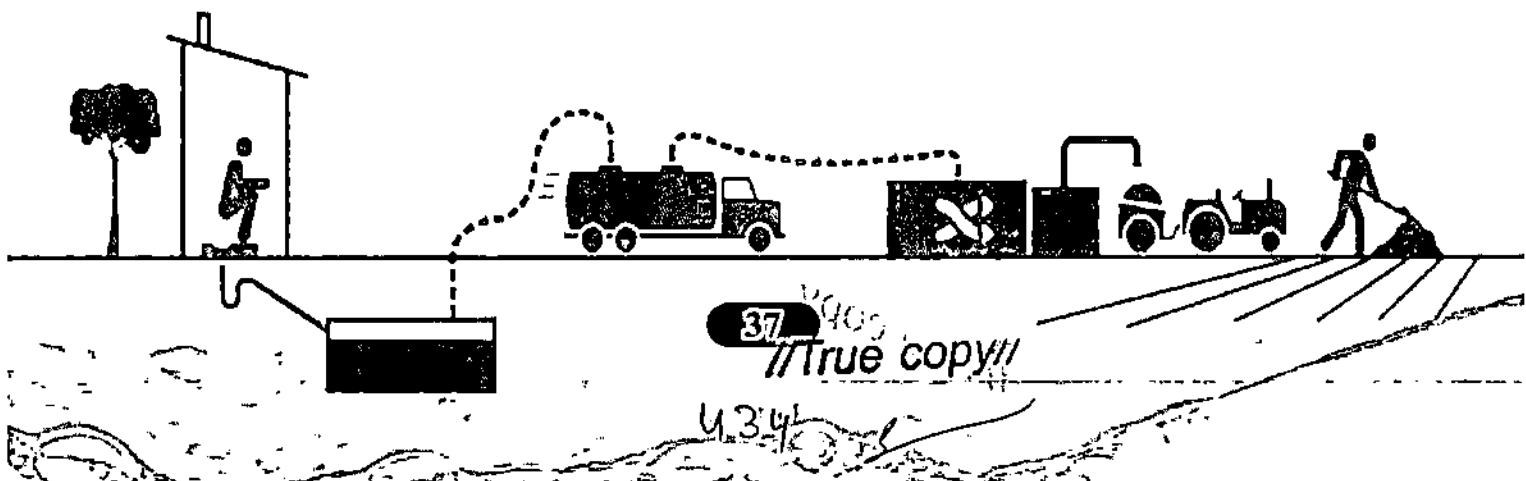

4.6.1.2 Scroper

The scroper is an assembly of wooden planks of a size slightly smaller than the sewer line to be cleaned. The scroper chain is attached to a controller, it is below the machine hole and then it is attached to a pulley via chains in the machine hole lying down. The pulley is operated to push the scroper debris forward. The flow coming from behind the scroper and the water falling over the scroper also helps to push it forward. This process ensures the cleanliness of the bottom and sides of the sewer. The cleaned debris is immediately removed.



(Photo Credit: CPHEEO, Govt. of India)

4.6.1.3 Hand Cross Holder

This device has been developed locally by the Municipal Corporation, Indore. With this equipment, the machine hole can be cleaned without going inside. It can be easily manufactured and used locally. With this equipment, sludge up to 5 kg can be removed from the machine hole/chamber at a time.

This equipment is made from galvanized steel and pipe. Its weight can be up to 5 kg and its length can be up to 20 feet.

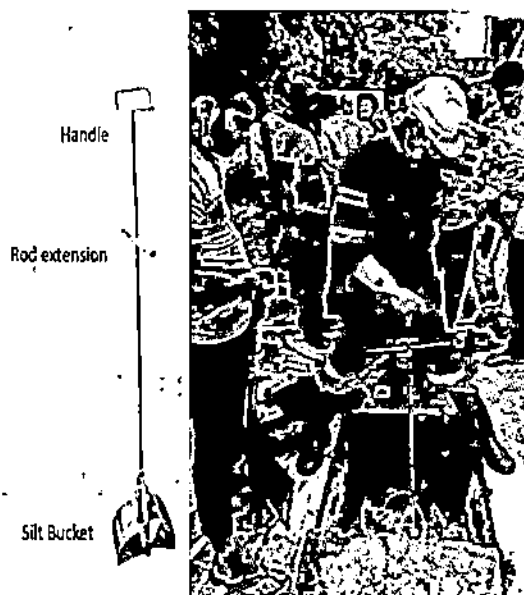

(Photo Credit: Municipal Corporation, Indore, M.P.)

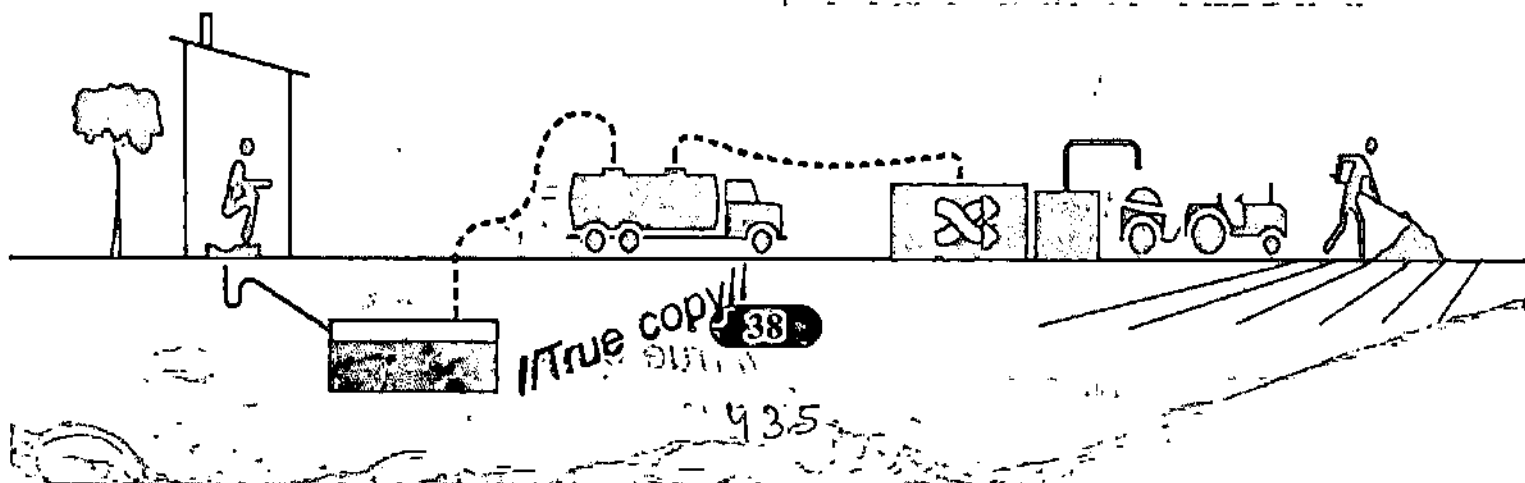

4.6.2 Mechanical Methods

Mechanical Equipment

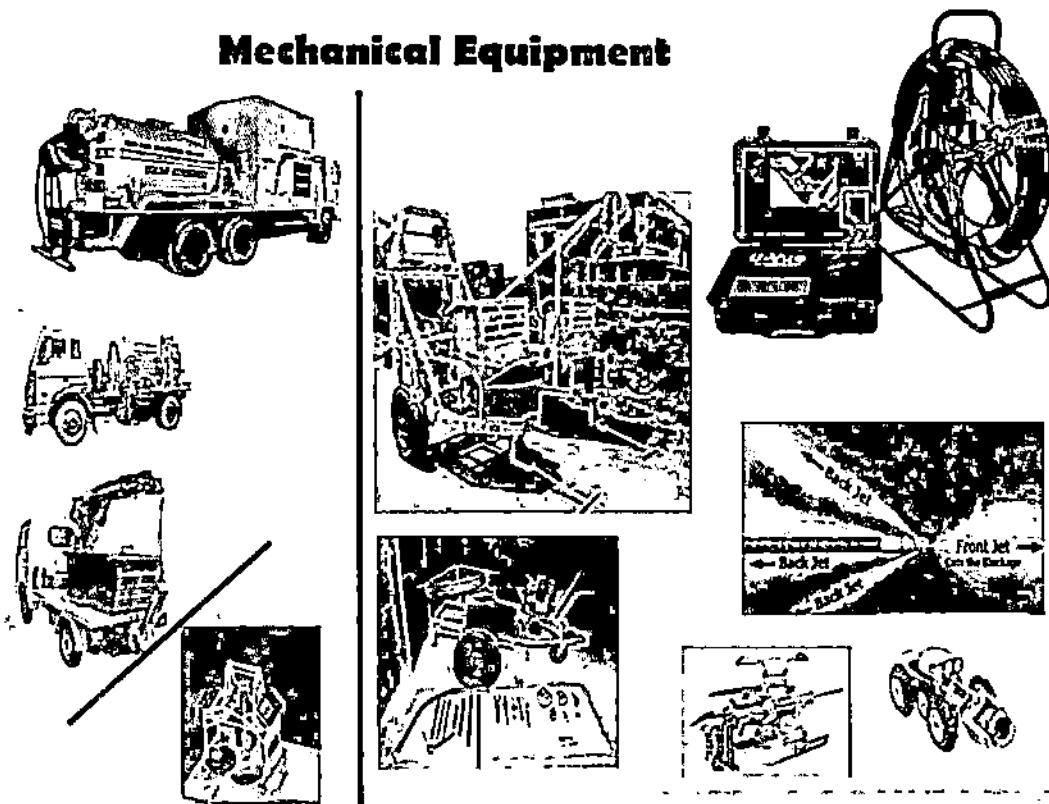

(Photo Credit: CPHEEO, Govt. of India)

4.6.2.1 Sewer Cleaning Bucket Machine

The bucket machine consists of two powered winches with cables in between. For cleaning a section of sewer, the winches are centered over two adjacent manhole holes. To get the cable from one winch to the other, it is necessary to thread the cable through the sewer line by means of sewer rods. The cable from the drum of each winch is fastened to the barrel on each end of an expansion

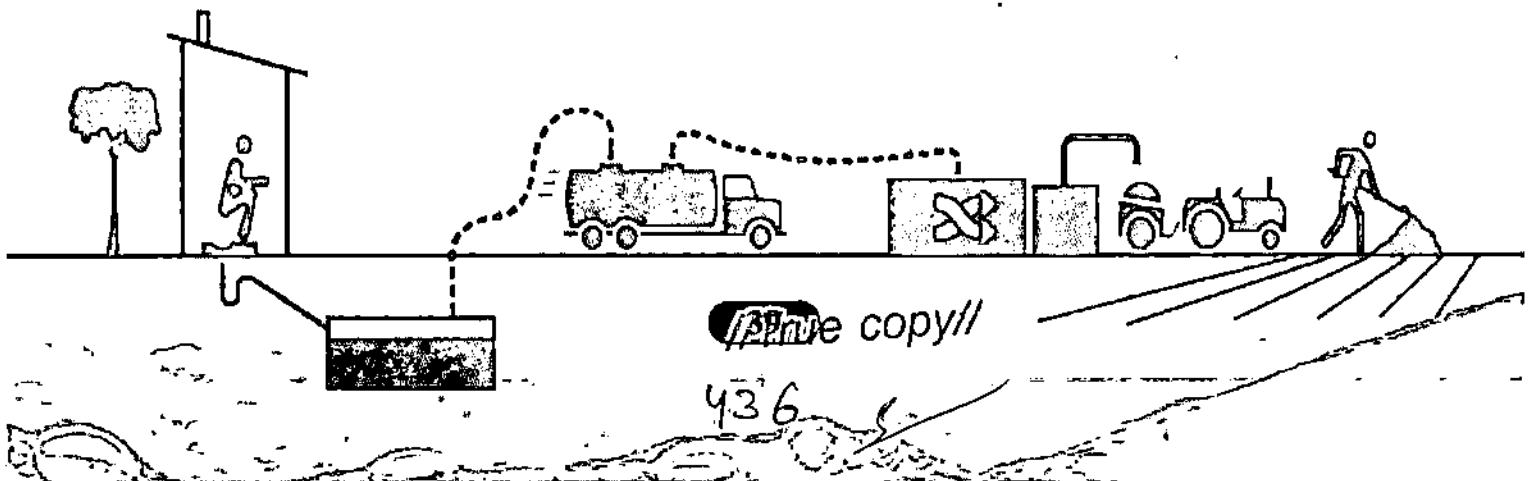

sewer bucket fitted with closing device, so that the bucket can be pulled in direction by the machine on the opposite end. The bucket is pulled into the loosened material to clean the sewer.

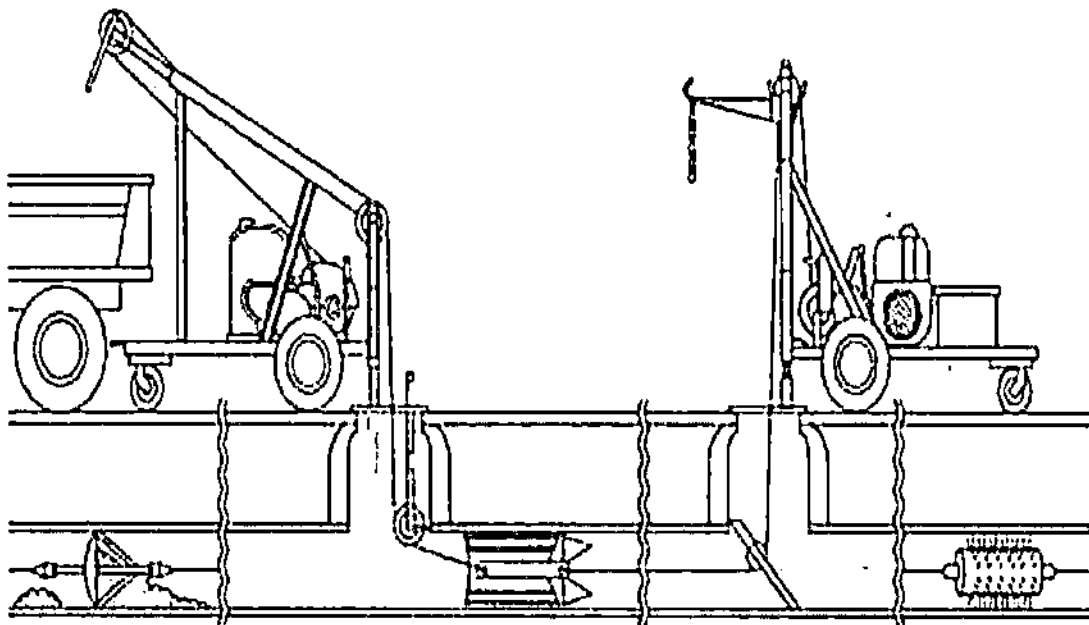

(Photo Credit: CPHEEO, Govt. of India)

4.6.2.2 Rodding Machine with Flexible Sewer Rods

This consists of a machine, which rotates a flexible rod to which is attached a cleaning tool such as auger, corkscrew or hedgehog and sand cups. The flexible rod is guided through the machine hole by a bent pipe. The machine propels the rod with the tool attached to one end, the other end being fixed to the machine. The rod is pulled in and out in quick succession when the tool is engaging the obstruction, so as to dislodge or loosen it. When the obstruction is cleared, the rod is pulled out by means of clamps keeping the rod propelled to facilitate quick and easy removal.

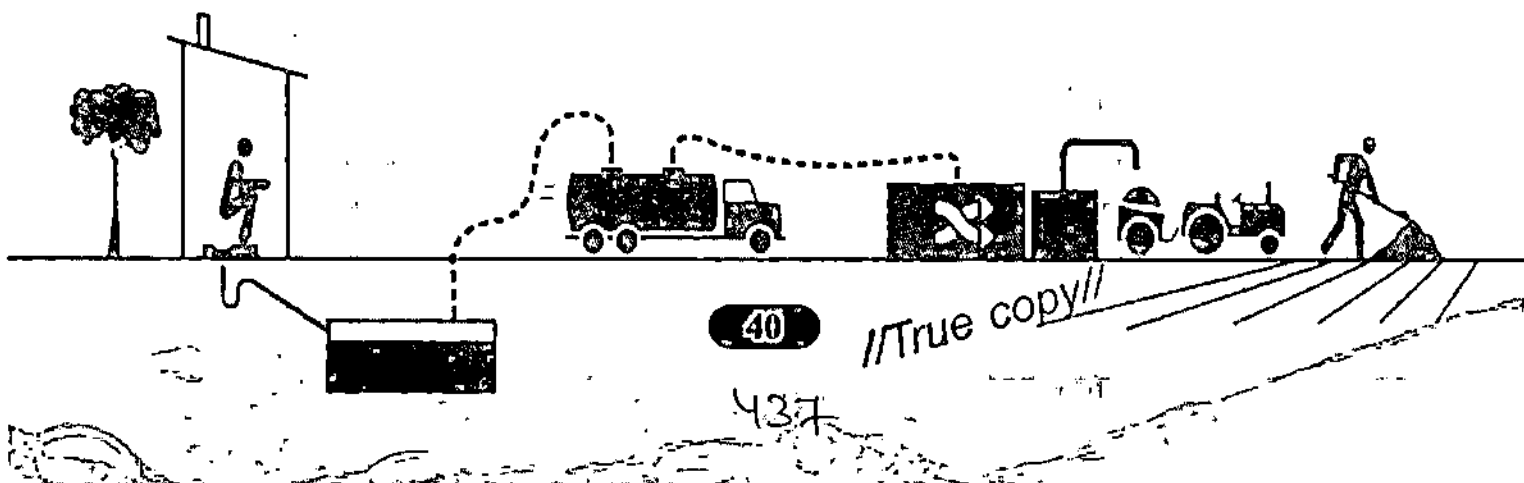

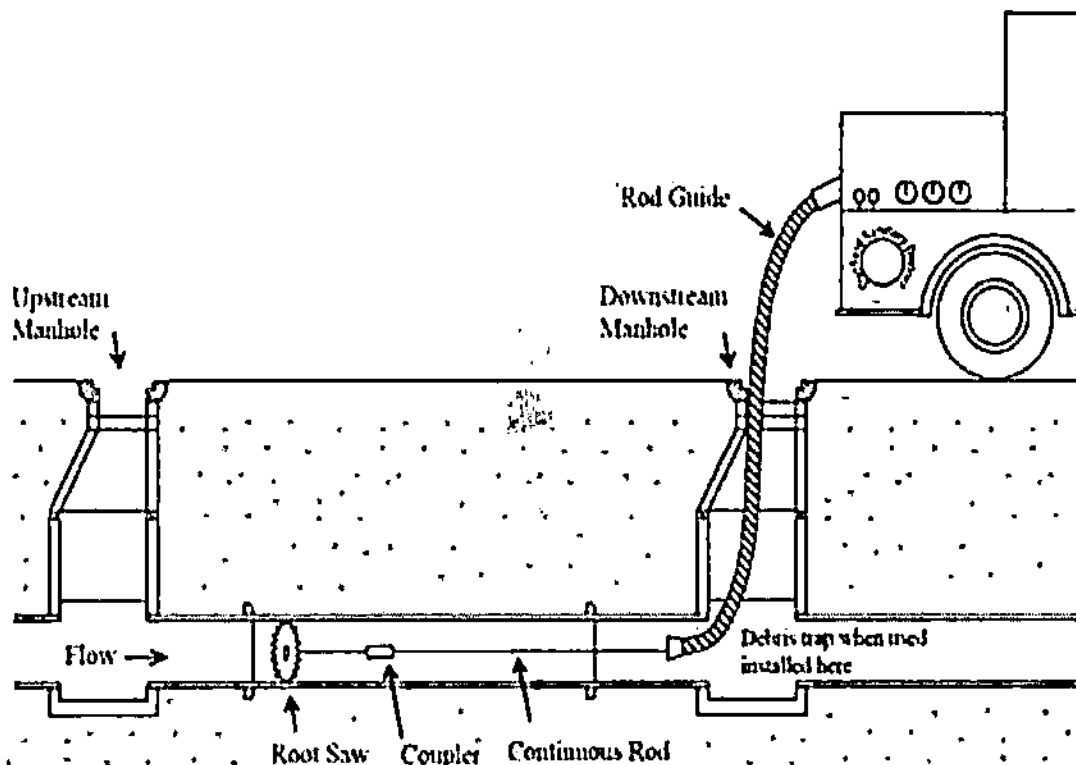

(Photo Credit: CPHEEO, Govt. of India)

4.6.2.3 Hydraulically Propelled Devices

The hydraulically propelled devices take advantage of the force of impounded water to effectively clear sewers. The efficiency depends on the hydraulic principle that an increase in velocity in a moving stream is accompanied by a greatly increased ability to move entrained material. The common hydraulically propelled devices are as follows:

- (i) Flush Bags
- (ii) Sewer Balls
- (iii) Sewer Scooters

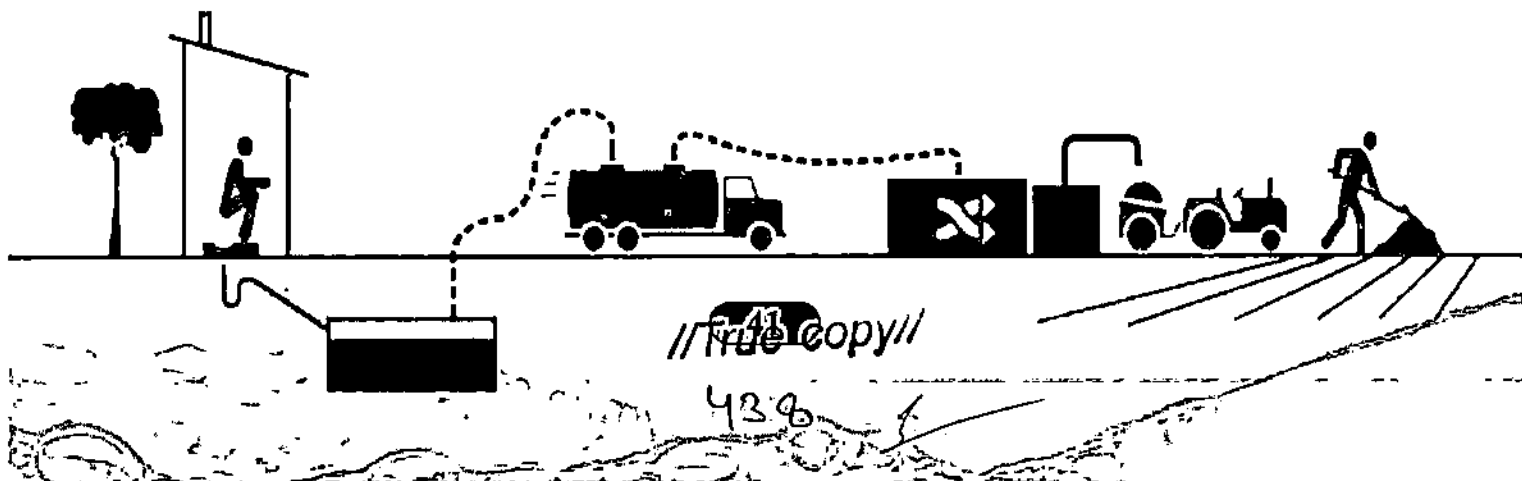

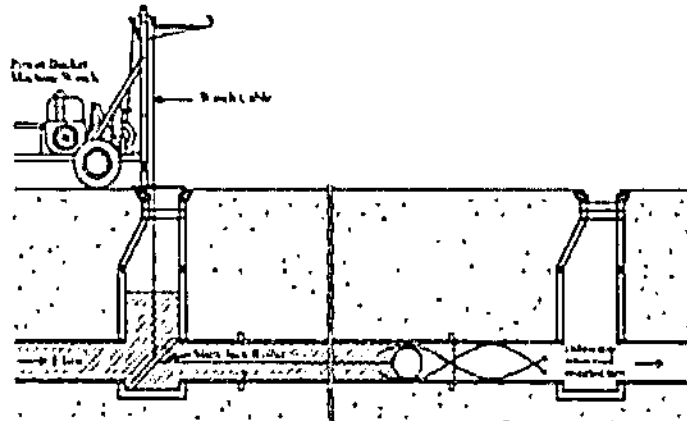

(Photo Credit: CPHEEO, Govt. of India)

4.6.2.4 Velocity Cleaners (Jetting Machines)

The high velocity sewer-cleaner makes use of high velocity waterjets to remove and dislodge obstructions. It combines the functions of a radding machine and gully emptier machine. It includes a high-pressure hydraulic pump capable of delivering water at variable pressure up to about 8 MPa through a flexible hose to a sewer cleaning nozzle. The nozzle has one forward facing jet and several peripheral rear ward facing jets. The high-pressure water coming out of the holes with a high velocity, breaks up, dislodges the obstructions, and flushes the materials down the sewer. Moreover, by varying the pressure suitably, the nozzle itself acts as a jackhammer and breaks up stubborn obstructions. A separate suction pump or airflow device may also be used to suck the dislodged material.

The entire equipment is usually mounted on a heavy truck chassis with either a separate prime mover or a power takes off for the suction device. The truck carries secondary treated sewage, if available, and if not untreated fresh water for the hydraulic jet. The truck also has a tank for the removed sludge and various controls grouped together for easy operation during sewer cleaning.

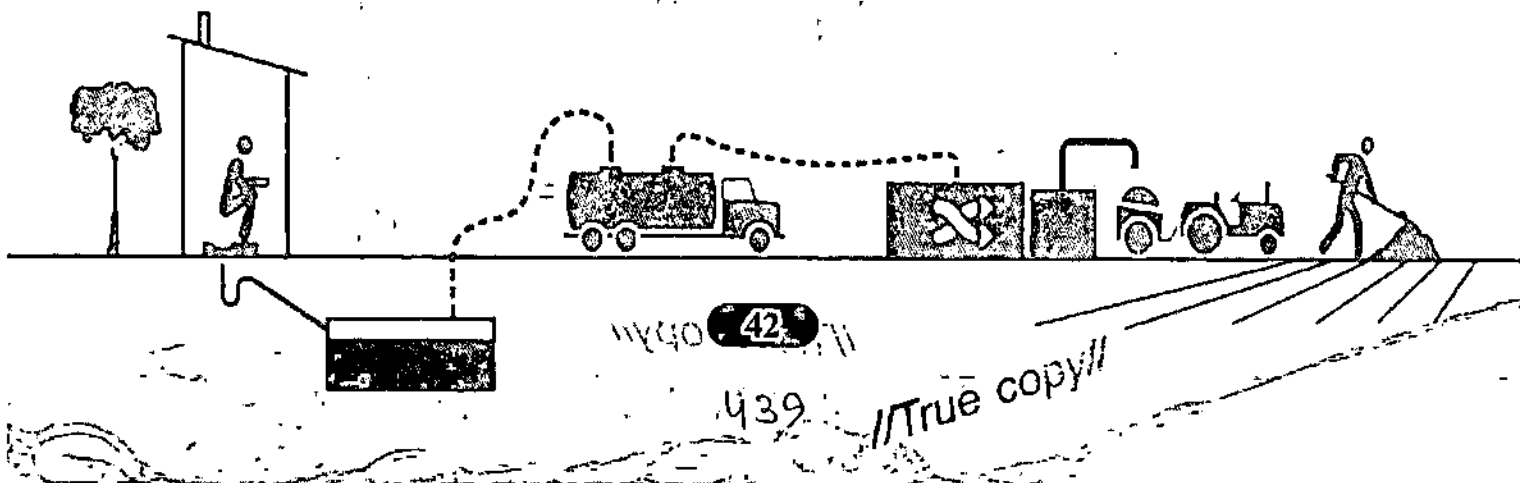

Now-a-days, Mini jetting machines are also available in the market which can travel into narrow lanes and clean the sewer lines up to a length of 200 feet (60 meters).

4.6.2.5 Dredgor (Clamshell) for machine hole cleaning

It consists of a grab bucket on a wire rope, which is lowered into the machine hole in an open condition with the help of a crane and pulley. On reaching the bottom of the machine hole, the segments are closed, and the accumulated silt is picked up. The bucket can be closed by wire ropes or by a pneumatically operated cylinder.

4.6.2.6 Gully Emptier (Suction Units)

Suction units create the vacuum required for siphoning of mud, slurry, grit, and other materials. The vacuum elevated is such as to siphon the materials from the deep machine holes catch-pits etc. having depth ranging from 1m to 8m in normal cases with an option to suck an additional 4m with the help of special accessories for the purpose. The unit can be vehicle or trolley mounted. Silt and heavy particles settled at the bottom can be agitated and loosened by pressurized air with the help of the pump and then sucked in a tank.

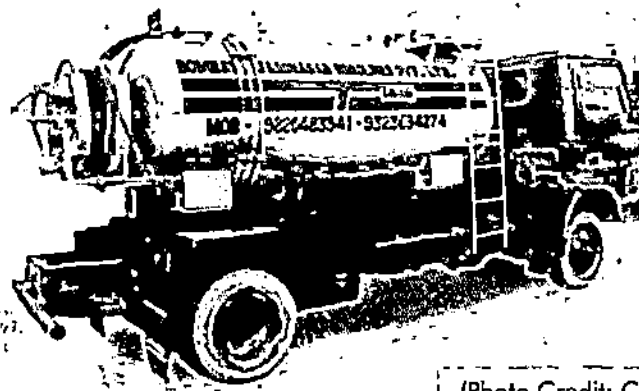

(Photo Credit: CPHEEO, Govt. of India)

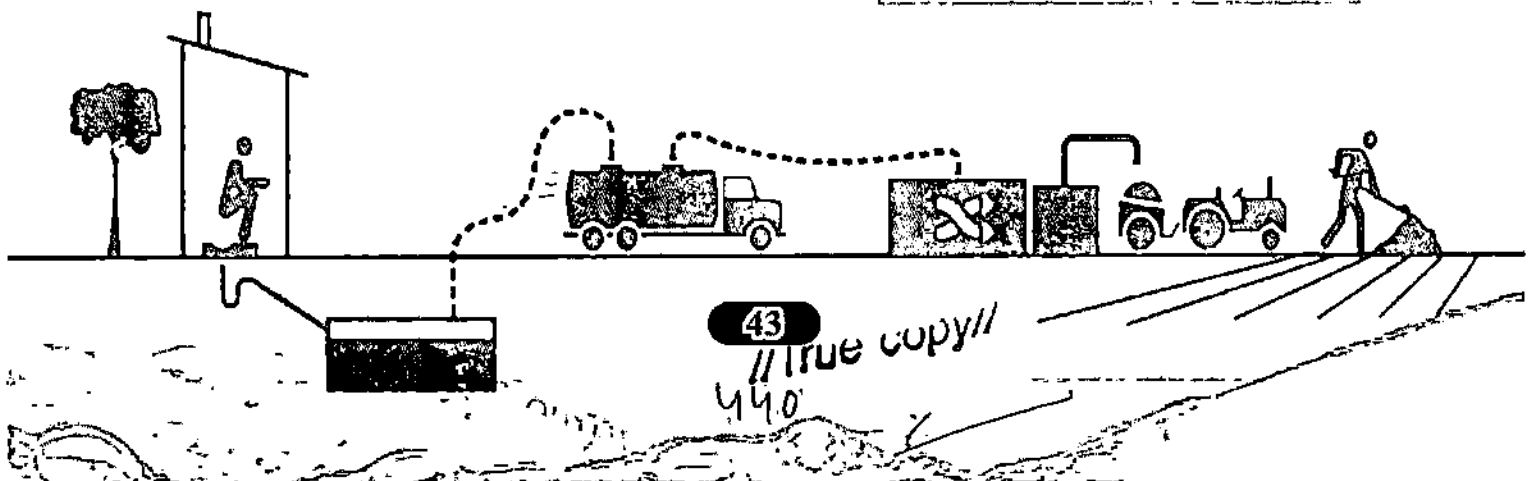

CHAPTER -5

EMERGENCY PREPAREDNESS AND PRECAUTIONS

5.1 Emergency Preparedness

- i. Emergency plan to execute the work shall be prepared before arriving at the site.
- ii. The supervisor and all the crew members involved in sewer/septic tank cleaning should be familiarized with the emergency plan.
- iii. A tripod attached with rope & pulley and harness, or some other suitable system shall be put in place for retrieving the injured worker.
- iv. A first aid kit distinctly marked with a red cross on white background shall be readily available at the site which should at least have the items listed in Annexure-VIII.
- v. Wash-up material like soap & skin cream for applying on the body shall be adequately available at the site.
- vi. A list (with contact no.) of medical care centers available near the site may be prepared and made readily available.
- vii. Vehicle preferably an ambulance shall be available at the site for carrying the injured worker(s) to the hospital, in case of any emergency.

5.2 Gas Emergency

- i. If a gas emergency occurs everyone should immediately put on their escape sets (breathing apparatus) and raise the alarm.
- ii. The men at the ground level are trained rescuers and they shall immediately send down the rescue sets and await the men working in sewer to come out. The men at the ground level shall attempt to rescue

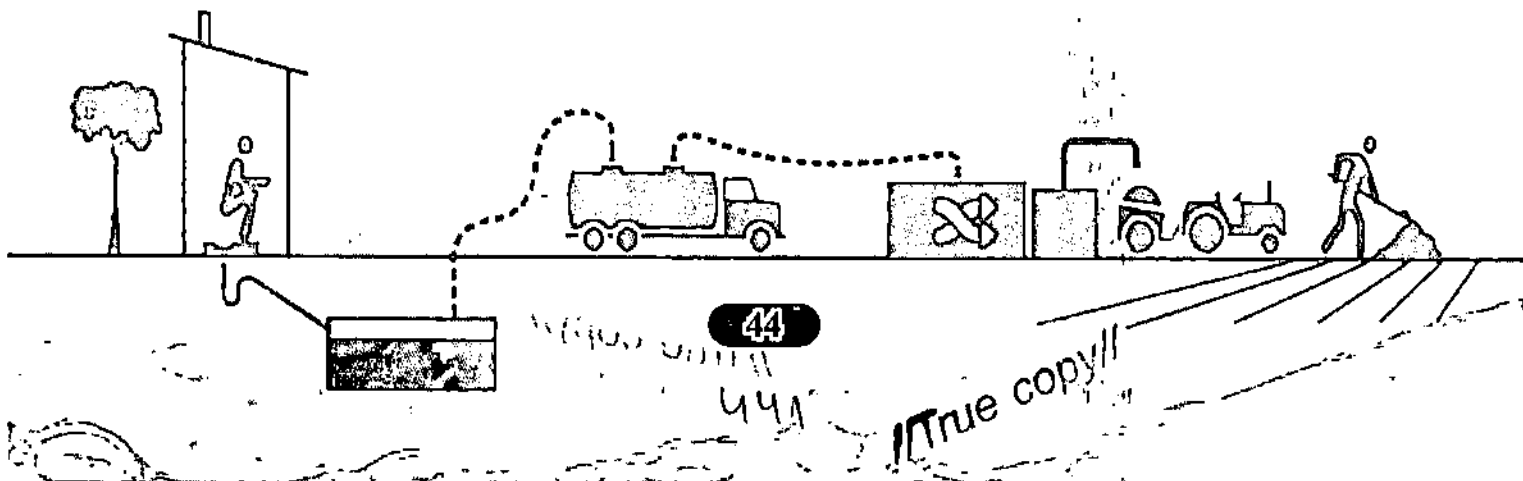

- the man inside sewer with all the equipment at their disposal.
- iii. If there is a casualty, he (should be propped up out of sewage in a comfortable position. Immediately call the emergency services (ambulance, fire brigade). When the victim has the gas mask on the face and if he is breathing, a rescuer should always be with him because he may vomit thereby choking the supply of oxygen.
 - iv. Guidelines for giving first aid to a gas victim are given below:
 - a. Remove him to fresh air as soon as possible.
 - b. Apply artificial respiration with an oxygen resuscitation if he is not breathing. If one is not available, apply mouth to mouth breathing.
 - c. Keep him lying down and wait for an ambulance.

5.3 Precautions

5.3.1 Precautions against Gas Hazards

When a sewer or a machine hole is required to be entered for cleaning or clearing an obstruction, where dangerous gas or oxygen deficiencies may be present, the following precautions shall be taken:

- i. The following shall not be allowed, (a) smoking, (b) open flames and (c) spark.
- ii. Erect warning signs.
- iii. Use only safety gas-proof electric lighting equipment or mirror for reflection of light.
- iv. Test the atmosphere for noxious gases and oxygen deficiencies. In case of scum formation, the sewage and sediments in the machine hole should be agitated with the help of rod or any other suitable instrument for trapped gases and the machine hole should be checked for noxious

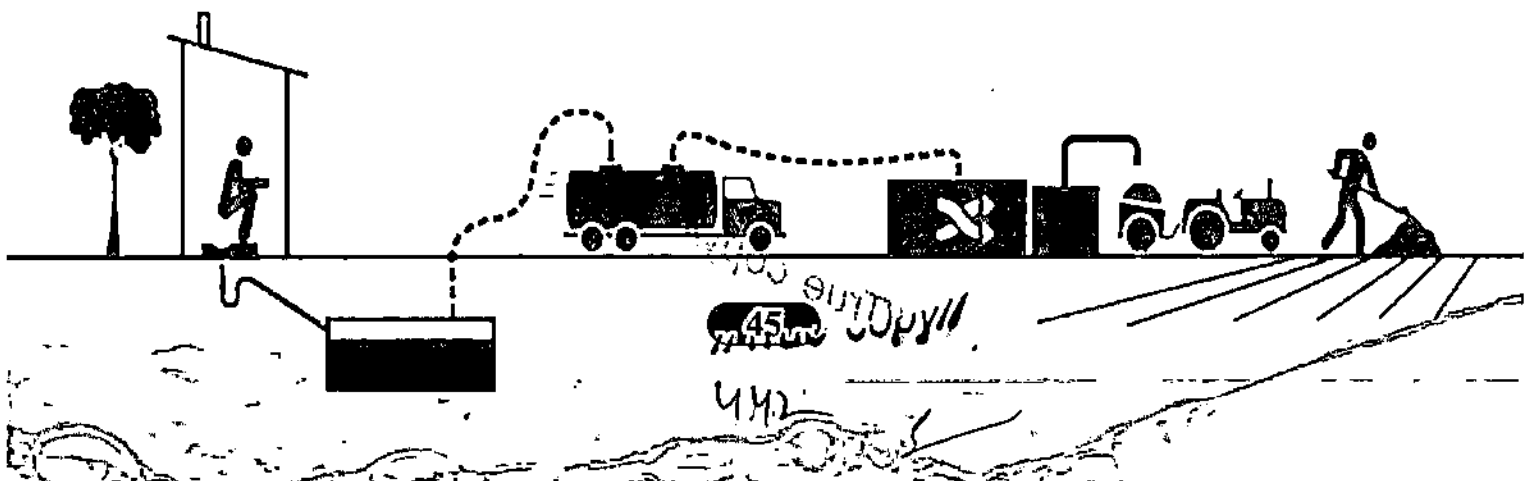

gases and oxygen deficiencies.

- v. If the atmosphere is normal, workmen may enter with a safety belt attached and with at least two men available at the ground level. For extended jobs, the gas tests shall be repeated every three minutes while men are in the sewer.
- vi. If oxygen deficiency or noxious gas is found, the structure shall be ventilated with pure air by keeping open at least one machine hole cover each on upstream and downstream side for quick exit of toxic gases or by forced ventilation using a portable blower. The gas tests shall be repeated before entering; Adequate ventilation shall be maintained during the work and the gas test shall be repeated every three minutes.
- vii. If the gas or oxygen deficiency is present and it is not practicable to ventilate adequately before workers enter, hose masks shall be worn, and extreme care shall be taken to avoid all sources of ignition. Workers shall be taught how to use the hose equipment. In these cases, they shall always use permissible safety lights (not ordinary flashlights) rubber boots or non-sparking shoes and non-sparking tools.
- viii. Workmen descending a machine hole shaft to inspect or clean sewers shall try each ladder step or rung carefully before putting the full weight on it to guard against insecure fastening due to corrosion of the rung at the machine hole wall. When work is going on in deep sewers, at least two men shall be available for lifting workers from the machine hole in the event of serious injury, and
- ix. Portable air blowers for ventilating machine holes are recommended for all tank, pit or machine hole work where there is a possibility of presence of noxious gas, vapors or oxygen deficiency. The motor of these air blowers shall be of weatherproof and flameproof type, compression-ignitions-diesel type (without sparking plug). These shall

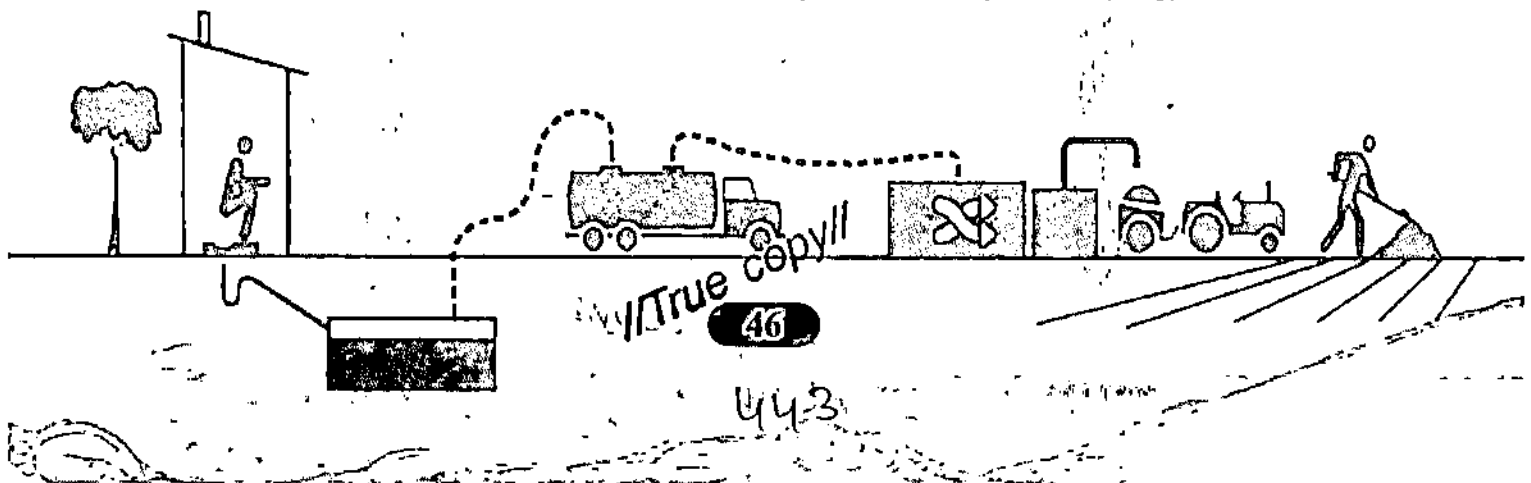

be placed not less than 2m away from the opening and on the leeward side protected from wind so that they will not serve as a source of ignition for any inflammable gas which may be present. Forced type ventilation should be provided by blower located at ground level with suitable flexible ducting to displace the air from the machine hole.

5.3.2 Precautions against Infestation

The personnel working in sewerage maintenance systems are prone to infections and hence the following precautions should be taken:

- i. The workers should be educated about the hazards of waterborne diseases such as typhoid and cholera through sewage and tetanus through cuts and wounds. Cuts and grazes should be covered with waterproof plasters. Effective immunization of workers against diseases such as typhoid, cholera, tetanus, etc. should be done by vaccination.
- ii. The importance of personal hygiene should be emphasized, and the worker should be instructed to keep fingernails short and well-trimmed, wash hands with soap and hot water before taking food and to keep fingers out of nose, mouth, and eyes, because the hands carry most infection.
- iii. Use of rubber gloves shall be insisted so that sewage or sludge does not come in direct contact with hand. Before starting work, skin likely to be exposed to sewage should be covered with barrier cream.
- iv. The worker should be provided with a complete change of work clothes to be worn during working hours. Gum boots should also be provided for the workers.
- v. When the work is completed, thoroughly wash all contaminated parts of the body.

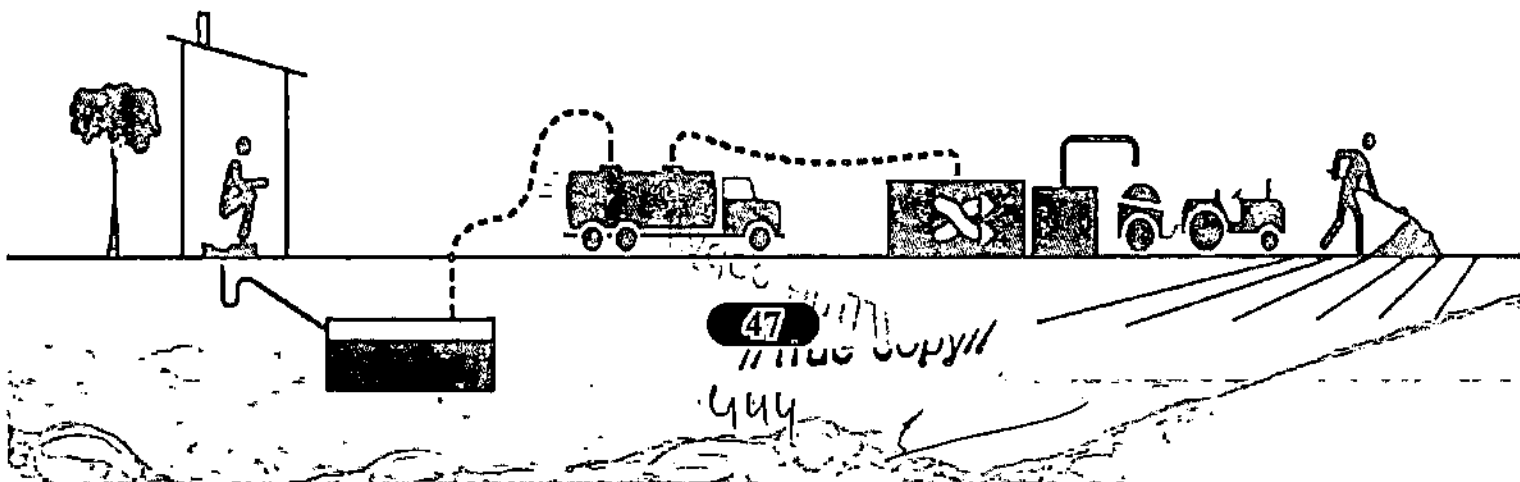

5.3.3 Precautions to be taken while working near Vehicular Traffic

- i. Safai Mitra's (on foot) exposed to vehicular traffic must wear fluorescent flagging garments.
- ii. Safai Mitra shall not wear any type of headgear/earphone that can interfere with hearing back up alarms, warnings, etc.
- iii. When hazards to workers exist because of vehicular traffic, use traffic controls in conformance with the Local Transport Authority.
- iv. Additionally, controls such as detours, warning signs, or barricades shall be used when necessary. Flagmen are required where these controls are ineffective.
- v. Wherever mobile equipment operation encroaches upon a public thoroughfare, a system of traffic controls must be used:-

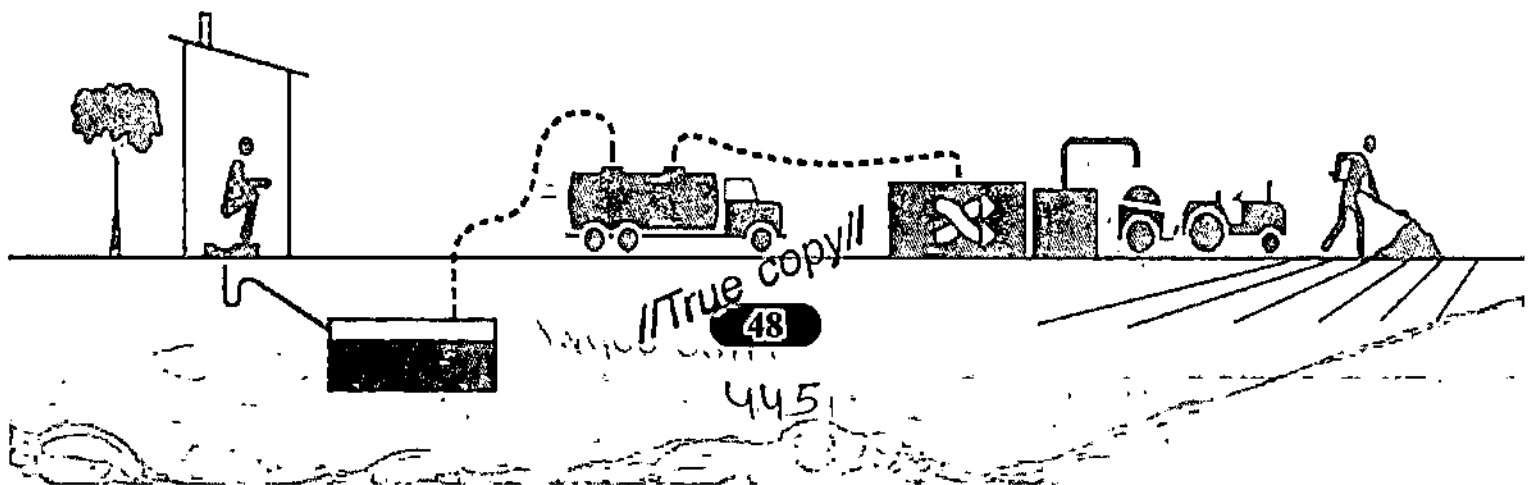

CHAPTER -6

PROTECTIVE GEARS AND SAFETY DEVICES

All the protective gears and safety devices shall be checked once in every six months and repaired/ replaced as necessary. The following (refer table 1) are the protective gears and safety devices, but not limited to, as prescribed by "Prohibition of Employment as Manual Scavengers and their Rehabilitation Rules, 2013" to prevent any hazardous entry of humans into the sewers. ULB's and provide additional gears/equipments as per local requirement.

Table-1

S. No.	Protective gears and safety devices
1.	Air compressor for blower
2.	Airline breathing apparatus
3.	Airline respirator with manually operated air blower
4.	Air purifier gas mask/chin corcege
5.	Artificial respiration/reticulate
6.	Barrier caution tope
7.	Barrier cream
8.	Barrier cone
9.	Blower
10.	Breath mask
11.	Breathing apparatus
12.	Caution board

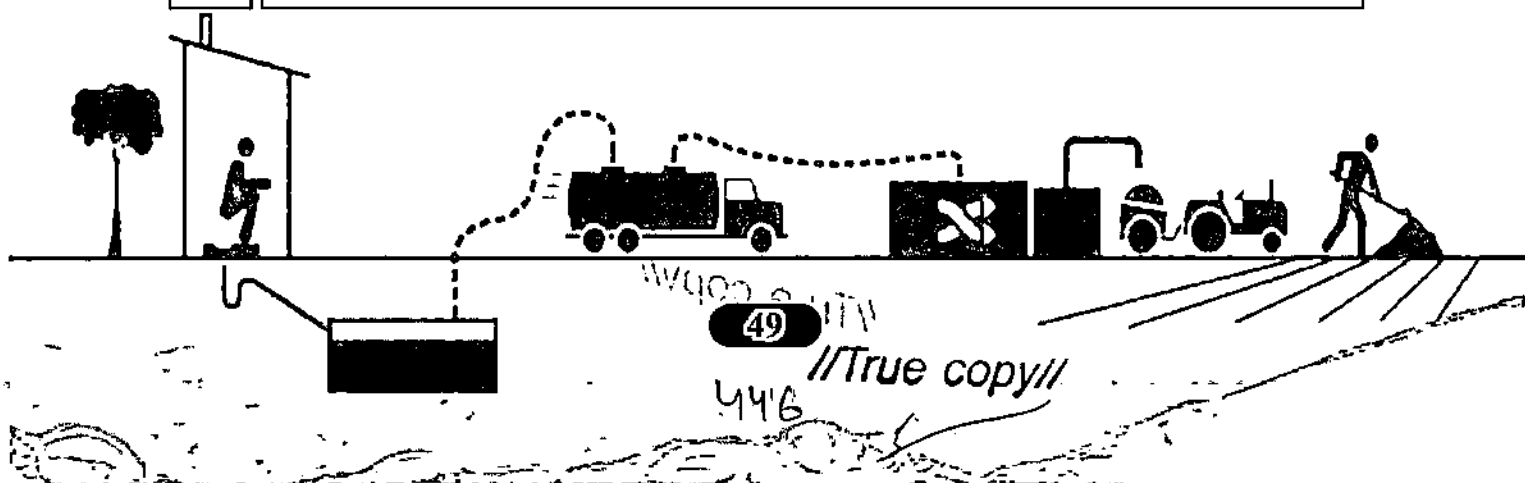

S. No.	Protective gears and safety devices
13.	Chlorine mask
14.	Emergency medical oxygen resuscitator kit
15.	First aid box
16.	Face mask
17.	Gas monitor (4 gases)
18.	Guide pipe set
19.	Full body wader suit
20.	Fishing wader suit attached with boots
21.	Hand gloves
22.	Head lamps
23.	Helmet
24.	Helmet demolishing
25.	Lead acetate paper
26.	Lifeguard pad
27.	Modular airlines supply trolley system
28.	Normal face mask
29.	Nylon rope ladder – 5 m
30.	Nylon safety belt
31.	Pocket book
32.	Port oxy
33.	Raincoat
34.	Reflecting jacket

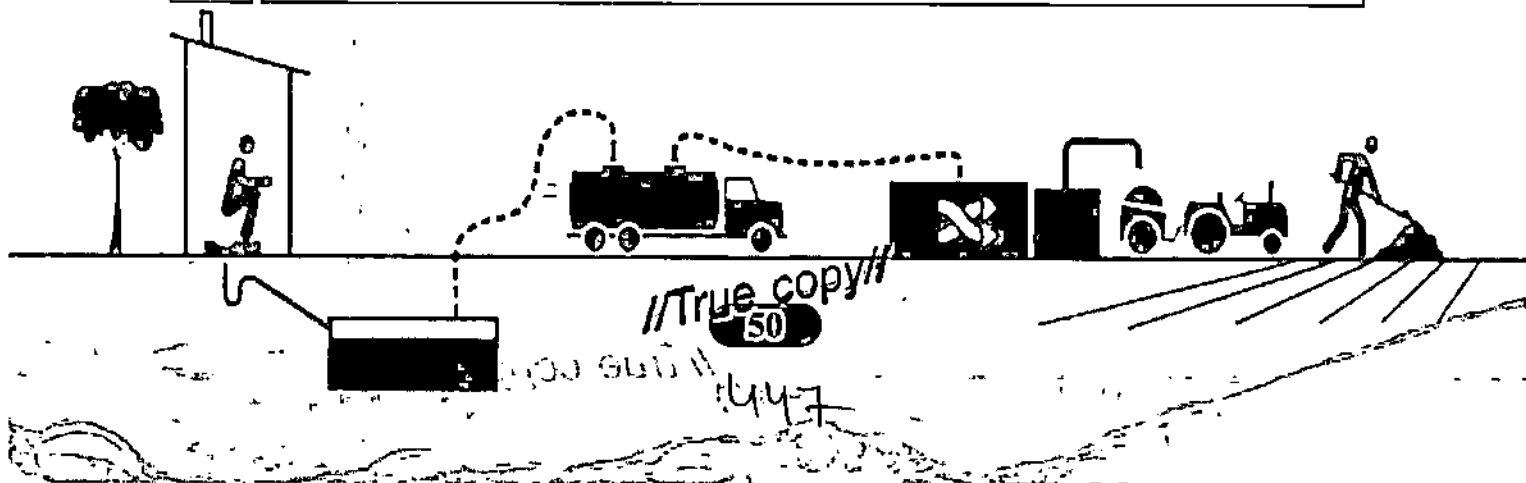

S. No.	Protective gears and safety devices
35.	Safety belt
36.	Safety body clothing
37.	Safety body harness
38.	Safety goggles
39.	Safety gumboots
40.	Safety helmets
41.	Safety showers
42.	Safety torch
43.	Safety tripod set
44.	Search light

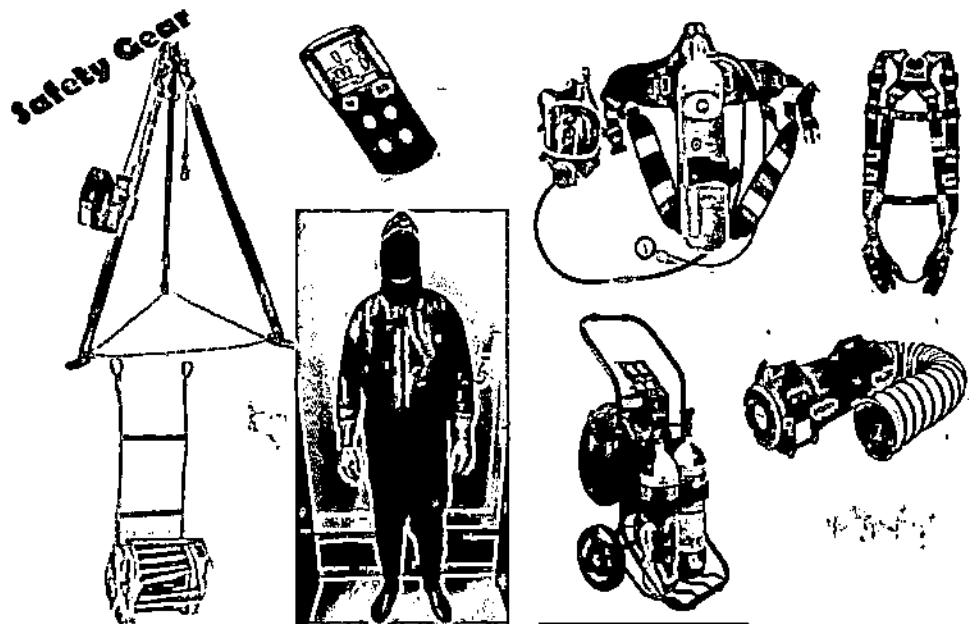

(Photo Credit: MOHUA, Govt. of India)

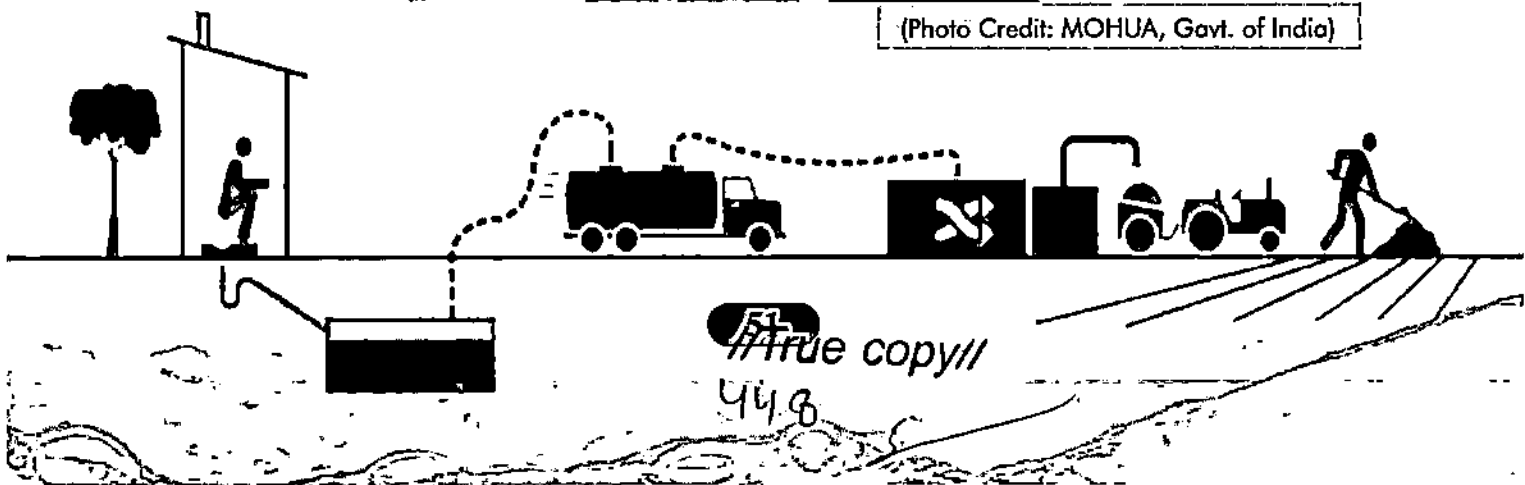

CHAPTER -7

GUIDANCE FOR SELECTION OF SEWER/ SEPTIC TANK CLEANING EMPLOYEES

7.1 Requirements for Duties not requiring Entry into Confined Space

No specific requirements except a routine medical examination shall be made. Those with the following disabilities shall not be selected :

- a) History of fits, blackouts, fainting attacks.
- b) Chronic skin disease and
- c) Meniere disease or diseases involving loss of balance.

7.2 Requirements for Duties Requiring Entry into Confined Space

Persons considered for employment in confined spaces shall be physically fit and capable of understanding training given. Those with the undernoted disabilities shall not be recruited for this type of work :

- a) A history of fits, blackouts, or fainting attacks.
- b) A history of heart disease or disorder.
- c) High blood pressure.
- d) Asthma, bronchitis, or a shortness of breath on exertion.
- e) Deafness.
- f) Meniere disease or disease involving giddiness or loss of balance.
- g) Claustrophobia or nervous or mental disorder.
- h) Back pain or joint trouble that would limit mobility in confined spaces.
- i) Deformity or disease of the lower limbs limiting movement.

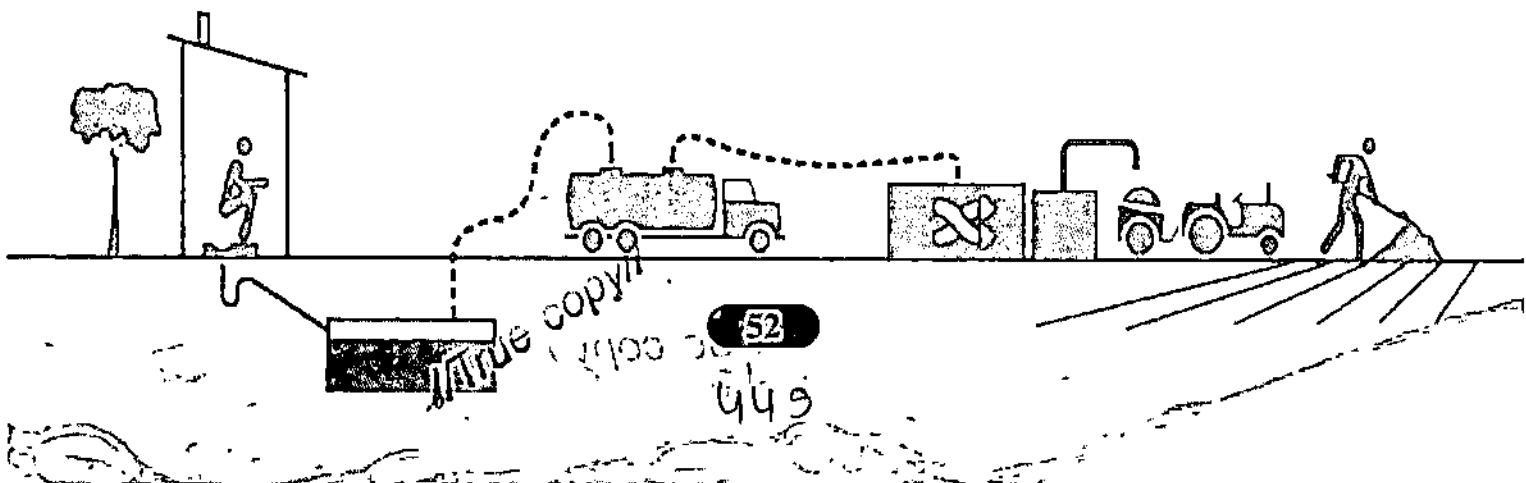

- j) Chronic skin disease.
- k) Serious defects in eyesight and
- l) Lack of sense of smell.

Safai Mitra's shall be medically re-examined at reasonable intervals, considering the person's age and duties.

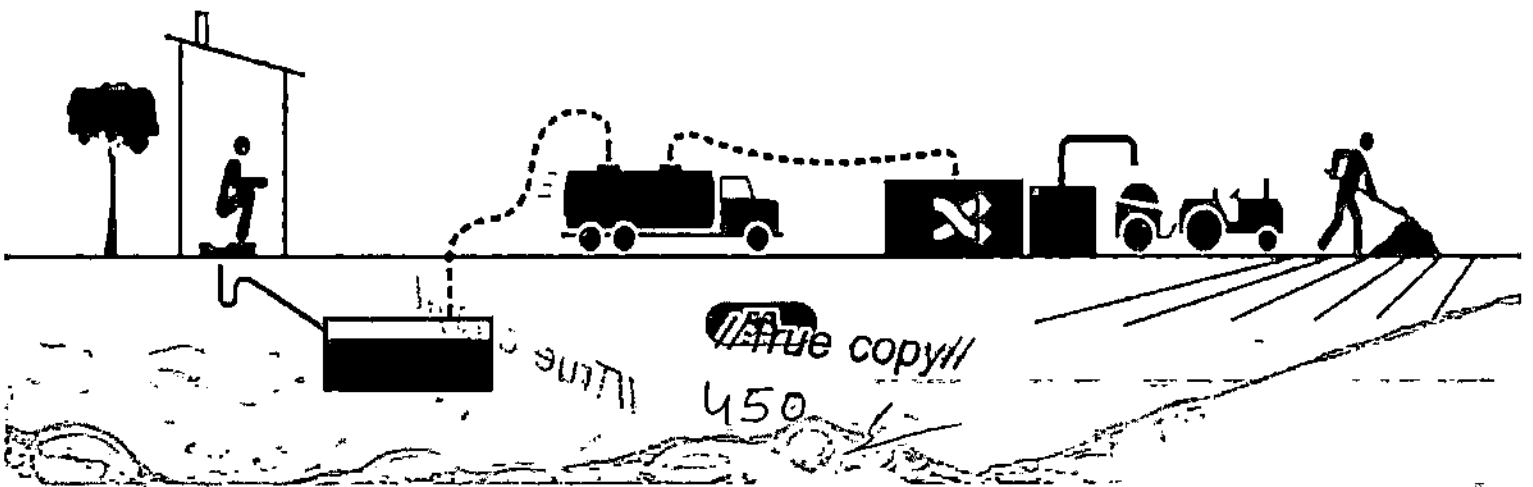

CHAPTER -8

REGLES & RESPONSIBILITIES

8.1 Urban Local Bodies (ULBs)

- i. ULBs shall authorize the Agencies for providing the cleaning of sewers and septic tanks by mechanical means or by manual means, in case, for private as well as public sewerage systems including pumping wells.
- ii. A list of registered agencies along with full contact details, trained manpower, availability of equipment's, and others shall be made available on public domain.
- iii. ULBs must conduct survey to identify manual scavengers/ sanitation workers (hazardous cleaning) in their jurisdiction and frame a mechanism to rehabilitate or integrate them to the system formally.
- iv. The supervisor of the sewer cleaning activity shall be properly trained on the first aid and cardiopulmonary resuscitation procedures by the ULB.
- v. All the workers involved in cleaning shall be familiarized with the operating procedures of cleaning equipment and emergency procedures by the ULBs.
- vi. Sewerage system may be mapped on Global Positioning System (GPS) to identify and reach the complaint area and perform the activities at the earliest.
- vii. Training programs on the technique, equipment operation and emergency procedures shall be conducted for them once in every two years.
- viii. Sufficient copies of the operating procedures of the cleaning machines/ equipment shall be maintained by the ULBs in local language and the copies of the same shall be made available to the field staffs.

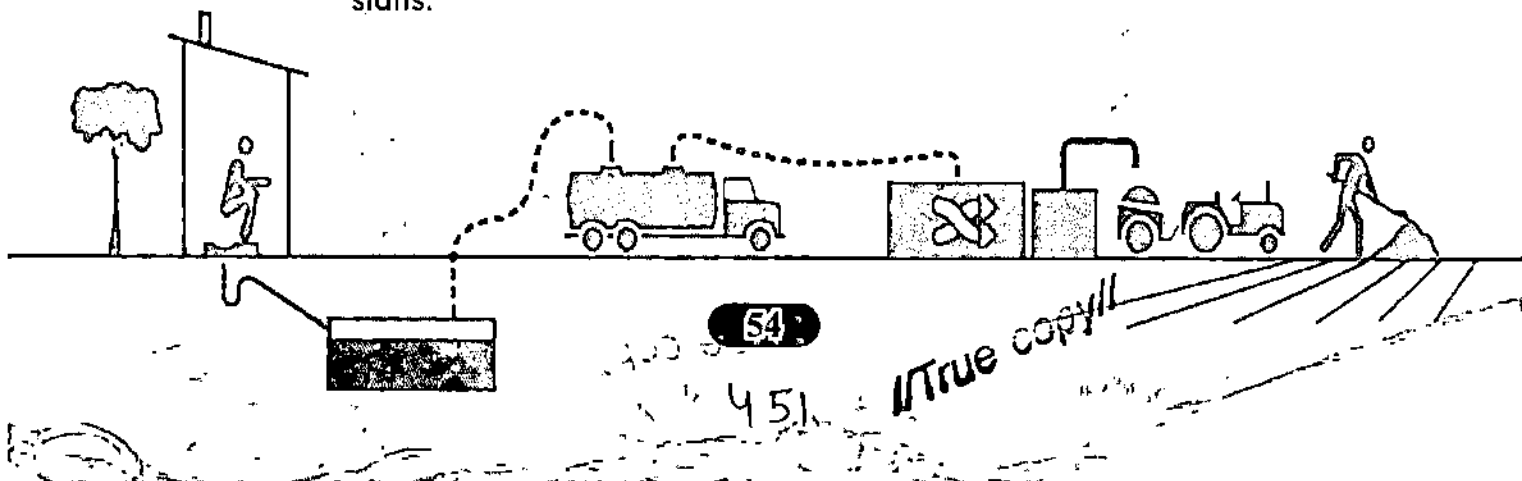

- ix. ULBs shall ensure that all cleaning staff undergoes regular medical checkups and administered vaccinations as deemed appropriate and shall maintain proper records of the same.
- x. ULBs shall ensure the staffs assigned for cleaning sewers/septic tanks has a life insurance policy for at least Rs. 10 lakhs, for which the premium shall be paid by the employer.
- xi. ULBs shall maintain the complete contact details of the owners of cleaning machines/vehicles operating in their jurisdiction and ensure all the septage collected by them is emptied only at the designated sites.
- xii. ULBs shall also be responsible for any negligence of the Registered Agencies/Contractor/ Employers.
- xiii. ULBs are responsible for providing proper equipment, in case of direct involvement of ULBs in cleaning process.
- xiv. ULBs shall coordinate emergency activity with local authorities, in case of any emergencies to the crew members while cleaning sewers/septic tanks and
- xv. ULBs shall develop and put forth a mechanism to receive/register the grievances/concerns of the cleaning staffs and resolve them as soon as possible.

8.2 Registered Agencies/Contractors/Employers

- i. Registered Agencies/Contractors/Employers shall provide adequate safety gears and cleaning devices as prescribed in the SOP and the Rules.
- ii. Registered Agencies/Contractors/Employers are responsible for paying premium for life insurance of the staffs assigned with him/her for cleaning of sewers/septic tanks.

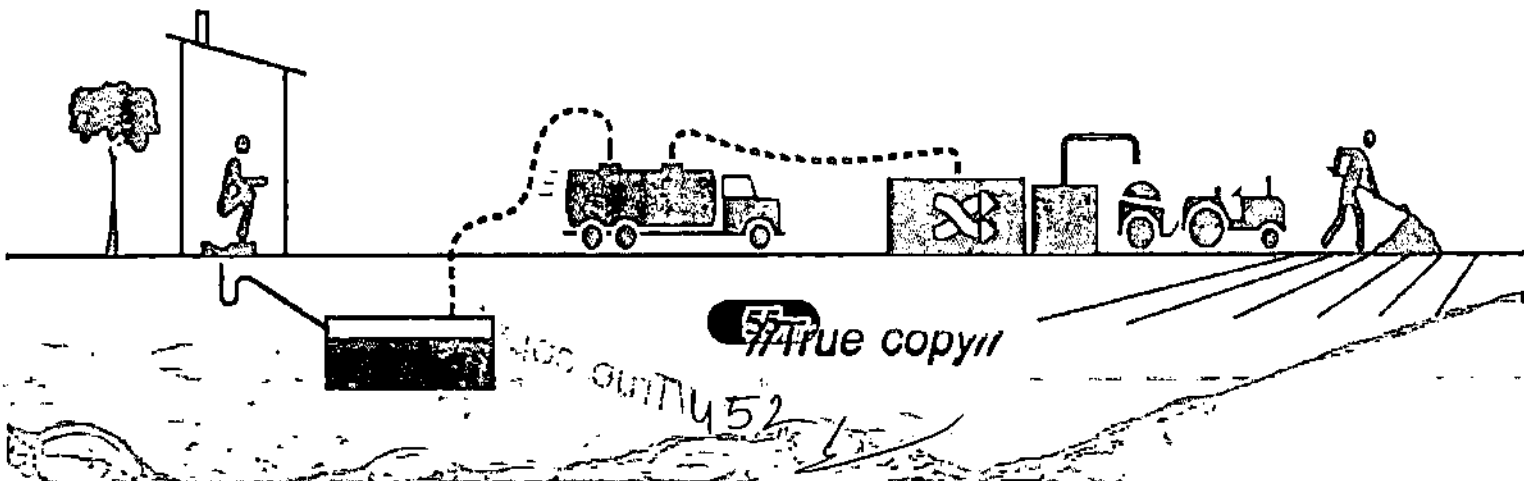

- iii. In consultation with ULBs, registered agencies/contractors shall ensure that all cleaning staffs undergoes regular medical check-ups and administered vaccinations as deemed appropriate.
- iv. Registered Agencies/Contractors/Employers shall ensure that all cleaning staffs are adequately trained and familiarized with the operating procedures of cleaning equipment and emergency procedures.

8.3 Employees

- i. Employees must familiarize them with the SOP and follow the procedures to ensure the personal safety and the safety of others.
- ii. In case of any doubt in the operating procedures of cleaning equipment and emergency procedures or inadequate training, the employee shall report the same to the concerned authorities.
- iii. Employees should, despite their discomfort, use all the necessary safety gears and cleaning devices when employed in cleaning sewers/septic tanks.
- iv. Employees without the knowledge and consent of the competent authority shall not involve in cleaning of sewers/septic tanks.

8.4 Individuals

- i. Any individual person shall not engage person for cleaning of sewers/septic tank in their premises on their own.
- ii. Individual shall always hire/employ the cleaning workers only through their ULBs or Authorized Agencies/designated agencies by ULB.
- iii. Individual shall inform to the ULBs officials in case of any casualty.
- iv. Individual shall keep the site free from any hazard, which can injure the workforce.

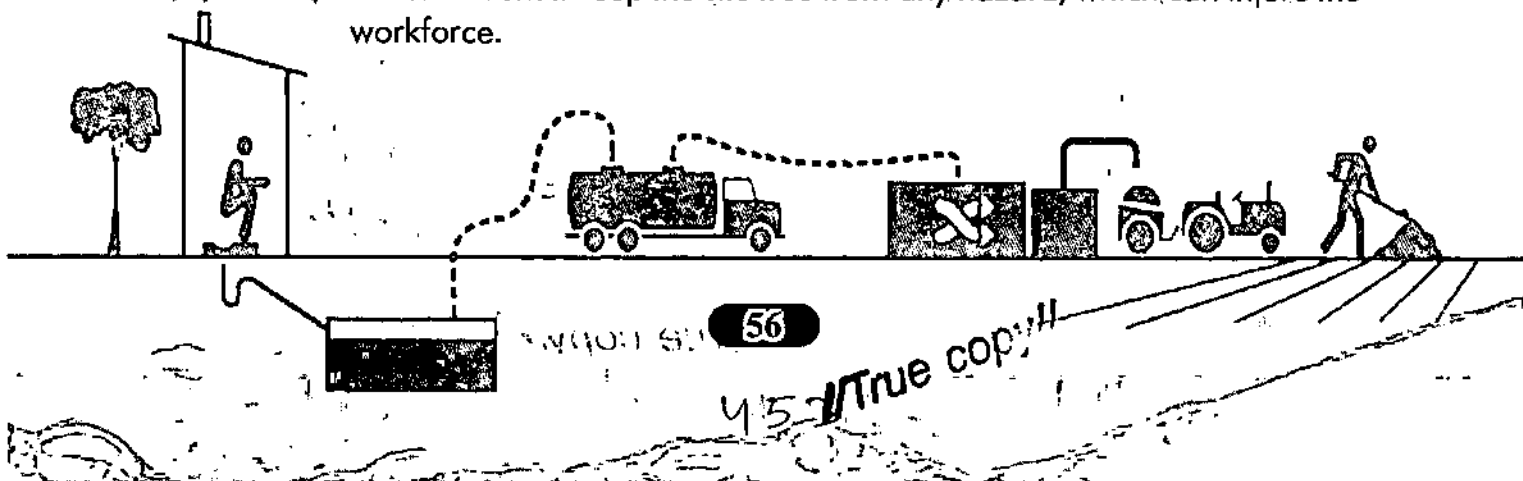

ANNEXURE

ANNEXURE - I

Standard uniform for Sanitation workers

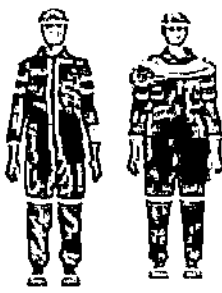
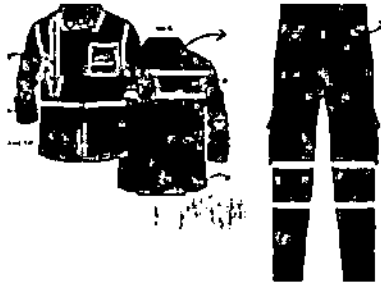
No.	Post	Roles	Uniform
1.	Swachata Cammando	Underground cleaning of Septic tank/Sewers (with safety gears)	
2.	Operator/ Supervisor	Operate machine, Road sweeping, supervise solid waste collection work, indirectly involved in the cleaning of common places	
3.	Safai Mitra	Road Sweeping, collection of solid waste from households	

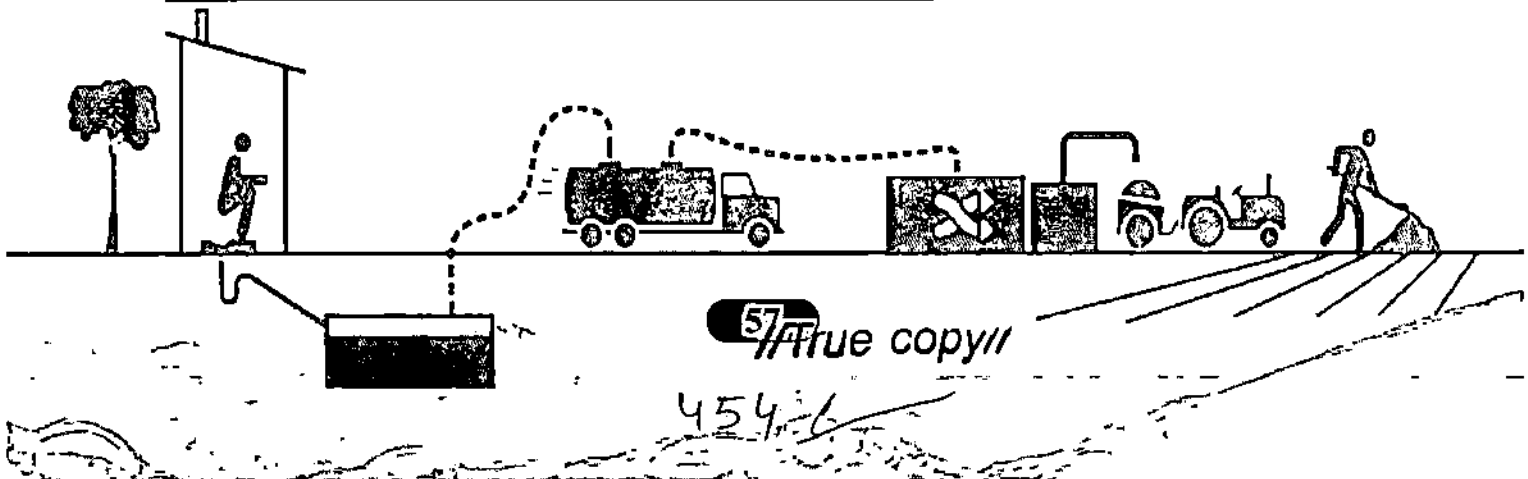

57 // True copy //

454.6

Uniform Design 1 – For Swachata Commando

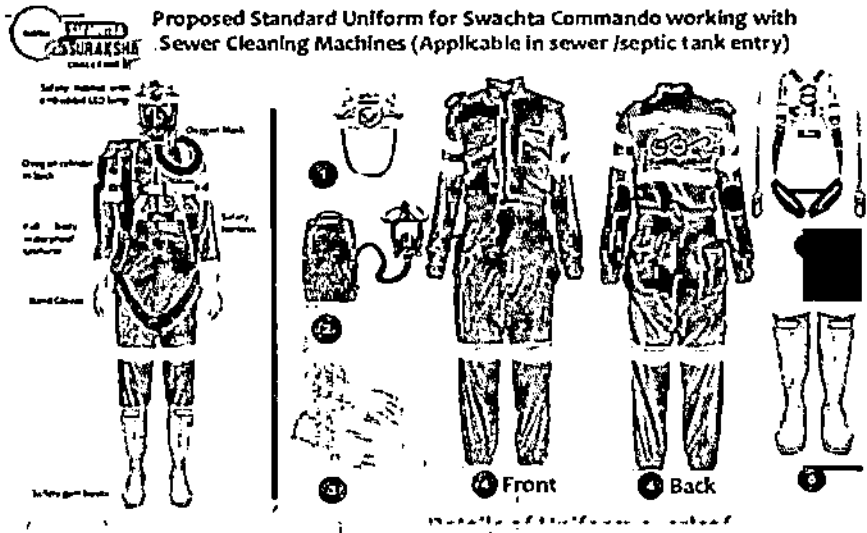

Uniform Design 2 – For Operator/Supervisor

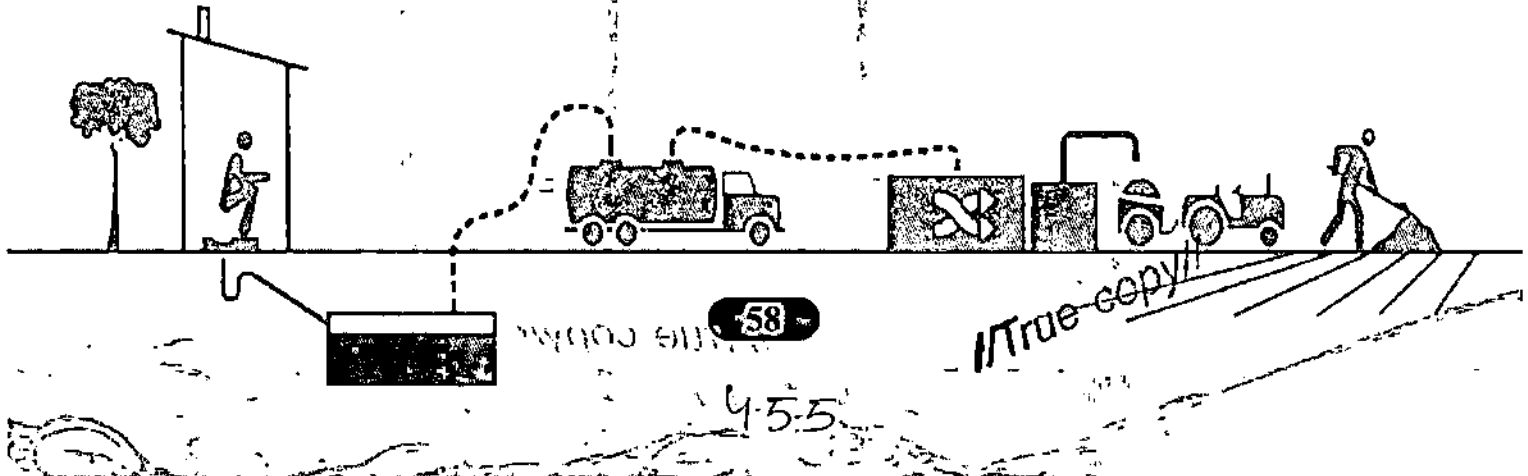
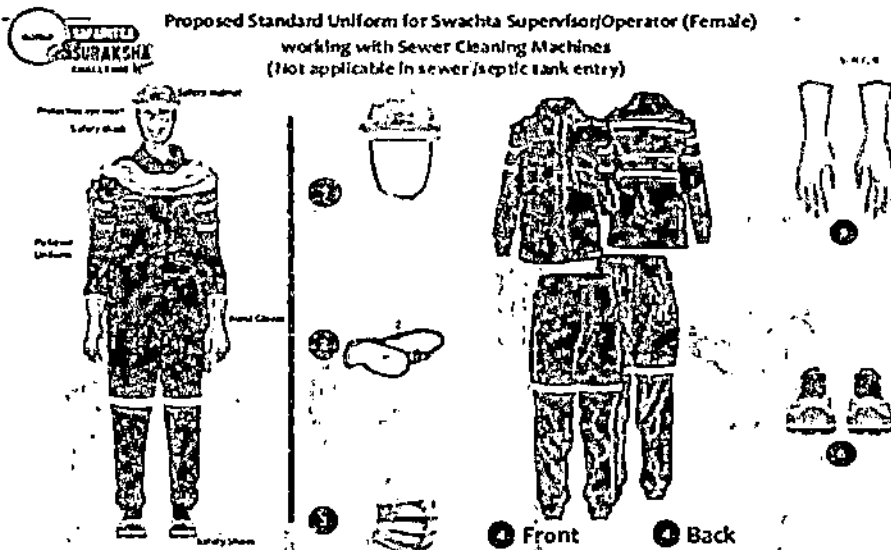



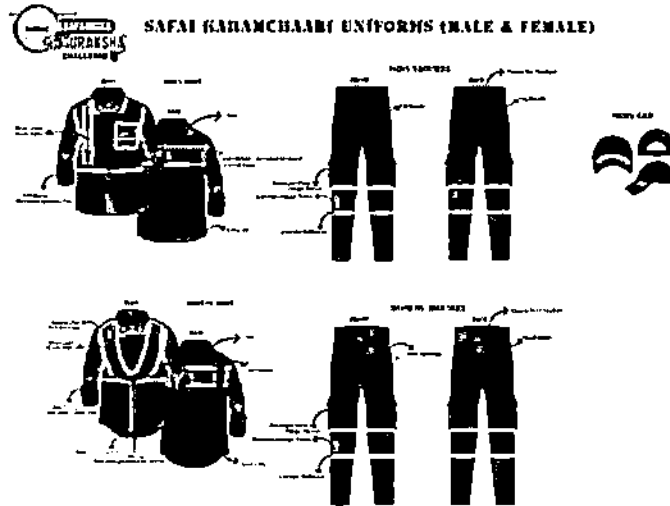



Uniform Design 3 – For Safai Mitra



(Photo Credit: MOUHA, Govt. of India)





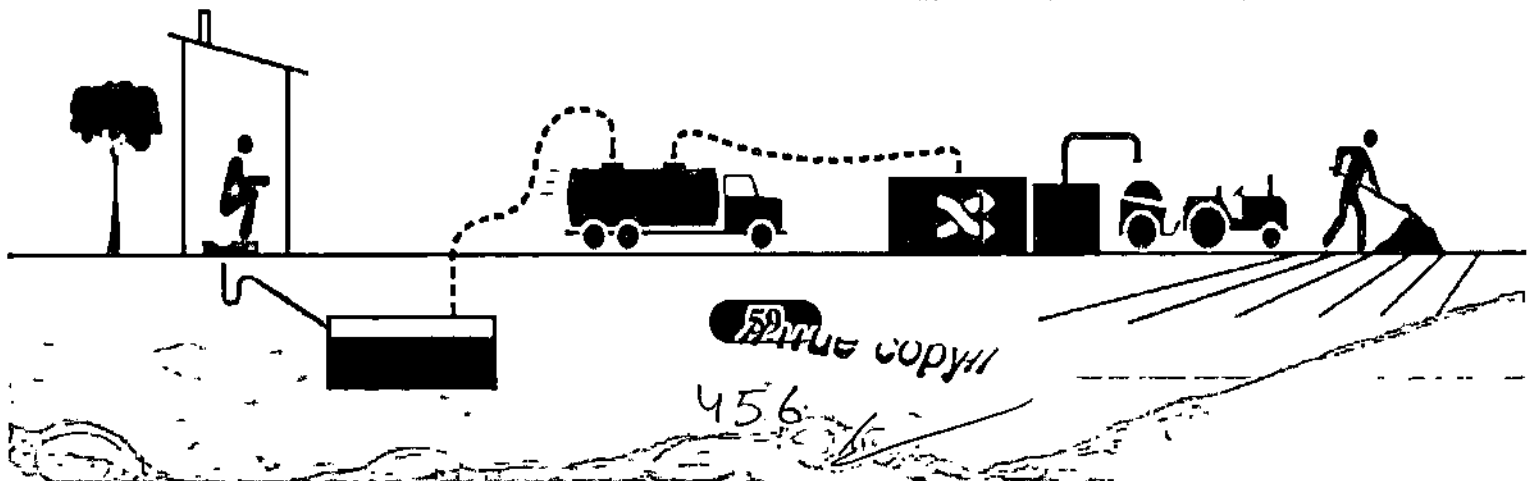

PPE kit for street sweeping/waste collection as per CPHEEO guidelines:

 <p>Particulate Mask with a nose clip</p>	 <p>Nitrile Gloves – 13" in length</p>	 <p>PVC water proof apron</p>
 <p>Comfortable shoes without steel toe</p>	 <p>High visibility reflective jacket</p>	 <p>Cotton sun hat</p>

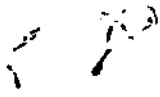
(Source: Urban Management Centre, 2020)









PPE kit for cleaning of community/individual toilets as per CPHEEO guidelines:

 <p>Safety Goggles with or without strap.</p>	 <p>Nitrile Gloves – 18" in length</p>	 <p>Particulate Mask with a nose clip</p>
 <p>PVC water proof apron</p>	 <p>Comfortable shoes without steel toe</p>	 <p>High visibility reflective jacket</p>

(Source:-Urban Management Centre, 2020)





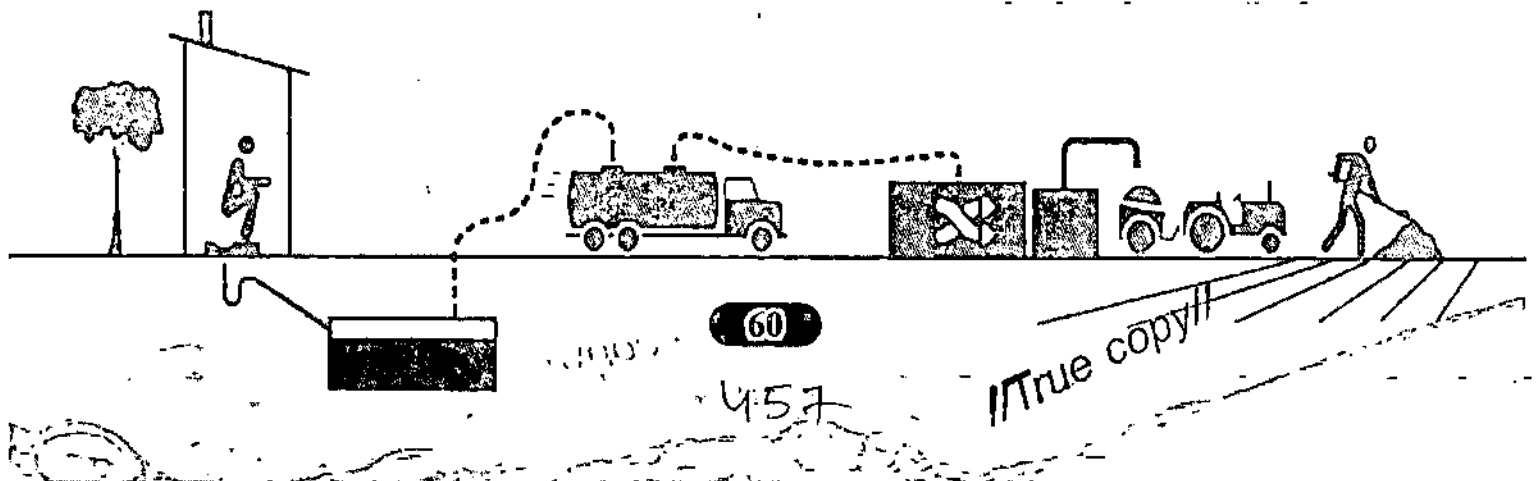

PPE kit for cleaning of open drains as per CPHEEO guidelines:

 <p>Particulate Mask with a nose clip</p>	 <p>Nitrile Gloves – 18" in length</p>	 <p>Safety helmet</p>
 <p>Thigh waders with attached boots</p>	 <p>High visibility reflective jacket</p>	 <p>Safety goggles with straps</p>

(Source:-Urban Management Centre, 2020)



PPE kit for FSTP/STP operator as per CPHEEO guidelines:

		
Safety helmet	Nitrile Gloves – 18" in length	Particulate Mask with a nose clip
		
PVC water proof apron	Gumboots without steel toe	High visibility reflective jacket

(Source:-Urban Management Centre, 2020)

PPE kit for cleaning of septic tank by using machines as per CPHEEO guidelines:

		
Respirator	Nitrile Gloves – 18" in length	Safety helmet
		
Gumboots without steel toe	High visibility reflective jacket	Safety goggles with straps

(Source:-Urban Management Centre, 2020)

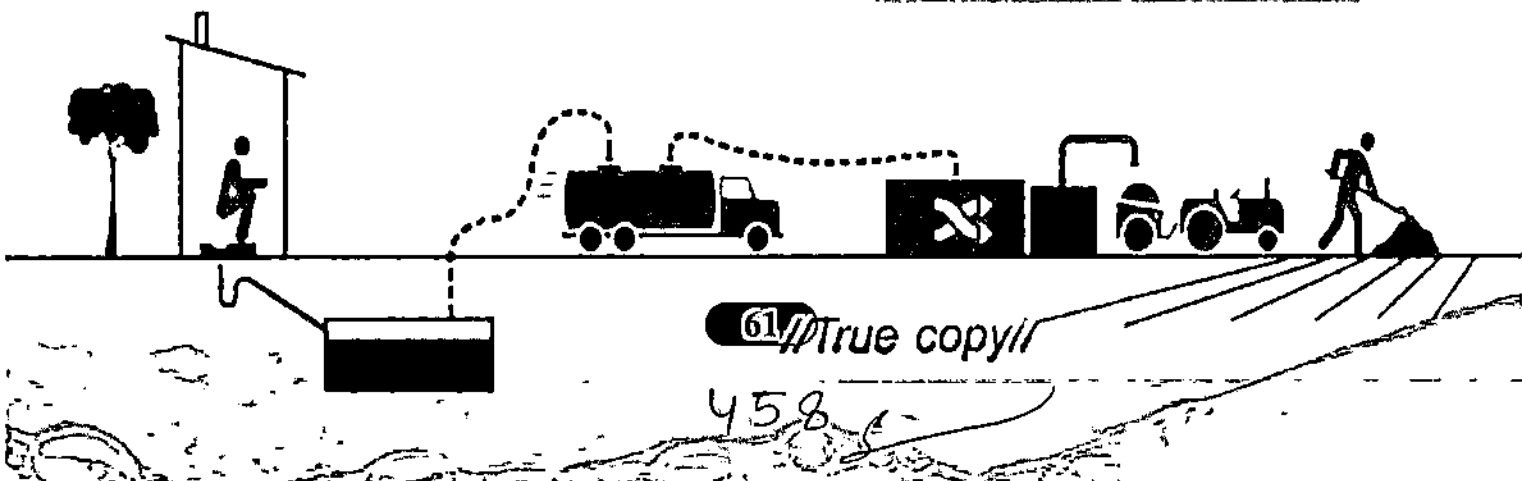

61 // True copy //

458

How to use PPE Kit

- Clean your hands properly before wearing face mask, gloves and glass,
- Keep your hands away from your face.
- While working do not touch other PPE kits. Do not touch your mask from outside.
- While working limit surfaces and items touched.
- After finishing your work remove your gumboots with gloved hands.
- Then remove your hand gloves and remove your mask and eye glass with clean hand.
- Keep the PPE's out of reach of children, and do not let children play with it.
- After completing the work clean your gumboots with water and dry them in shade.
- Properly Clean your apron, helmet, gloves etc. and keep them inside your house when they are dry.

How to dispose PPE Kits:

- You should always through discarded PPE's in bio-medical bins (yellow colored bins).
- If the bin is not available, please wrap your used PPE properly in a bag, mark it with red color and throw it in a dustbin.
- Please wash your hands after disposing the PPE.

(Source:-Urban Management Centre, 2020)

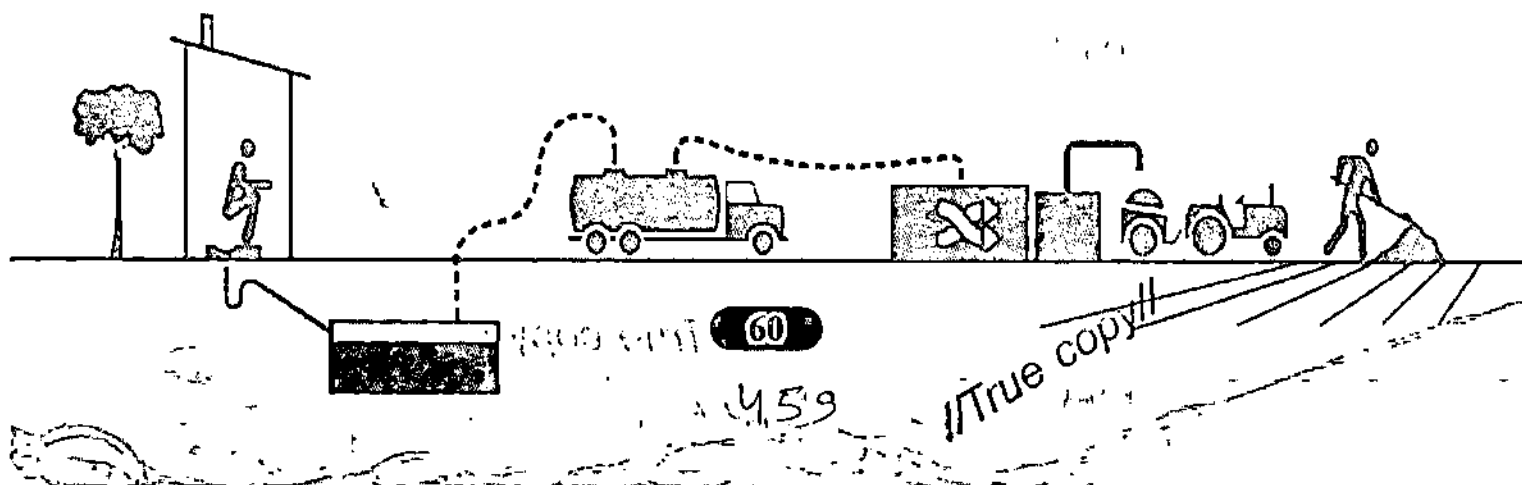

ANNEXURE - II

Do's and Dont's

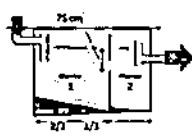
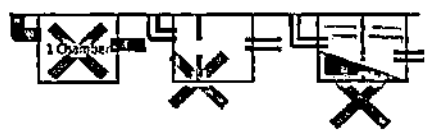
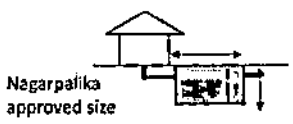
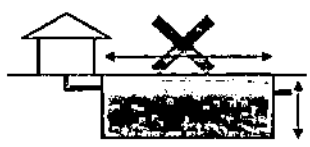
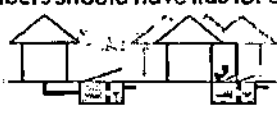
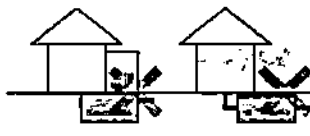
Do's	Dont's
<ul style="list-style-type: none"> ✓ Construct a septic tank with two chambers and one soak pit. ✓ The partition wall to be constructed only at a distance of 2/3 of the length from the inlet. ✓ Connect the two chambers through a pipe or square opening over the sludge. 	<ul style="list-style-type: none"> X Do not construct a single chamber septic tank. X The distance between the partition walls should not be less or more than the prescribed distance. X Do not connect the two chambers at a level where sludge or foam is generated. 
<ul style="list-style-type: none"> ✓ Make septic tank of proper size as per the guidelines of the municipality. 	<ul style="list-style-type: none"> X Do not construct a very large septic tank. 
<ul style="list-style-type: none"> ✓ The toilet structure should be away from the septic tank. ✓ If there is a shortage of space, then the toilet should be constructed in such a way that all the chambers are easily accessible. ✓ All chambers should have lids for easy opening. 	<ul style="list-style-type: none"> X Do not construct a toilet structure above the septic tank. X Do not completely seal the septic tank from the top. 

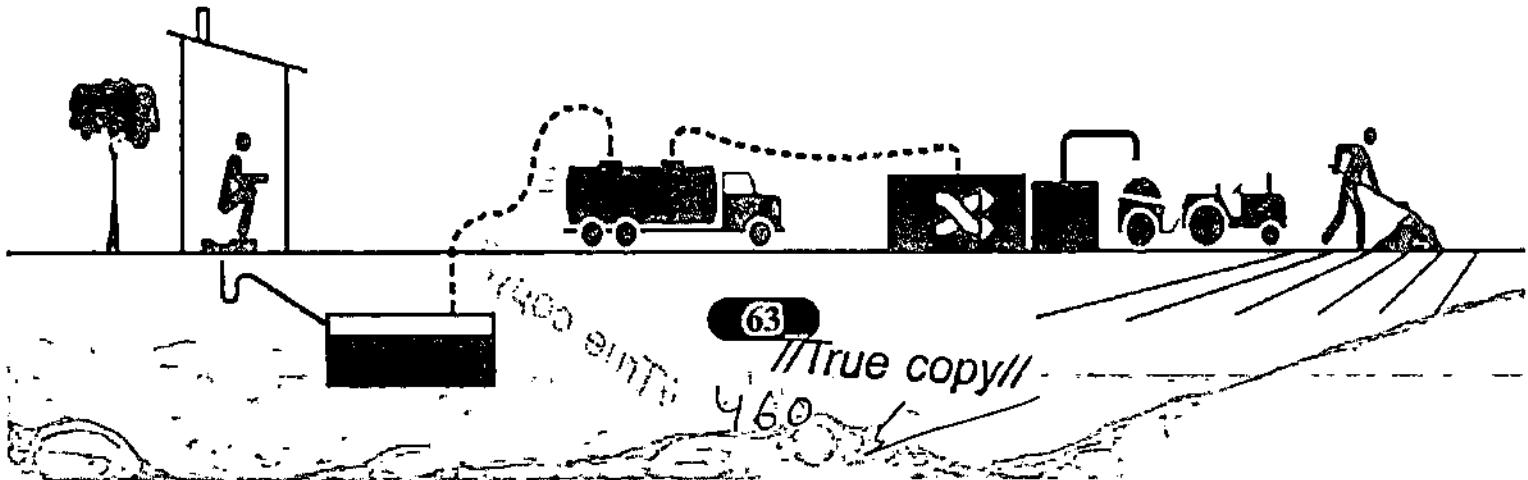

Do's

- ✓ The septic tank should be constructed by using brick/concrete or pre-cast material.



Don't's

- X The dug trench should not be used as a septic tank.
- X There should not be any leakage from the tank.



- ✓ The base surface of the septic tank should be made of cement concrete.
- ✓ The slope of the base surface should be higher at exit side.
- ✓ There should be cement plaster on the floor and walls of the septic tank.

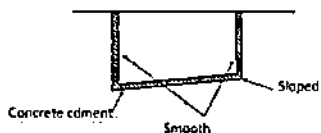

- X The surface of the septic tank should not be made from soil mud.
- X The slope should not be in the direction of exit.
- X The inside surface of the septic tank should not be rough. Don't just knit a brick and leave it.



- ✓ The inlet and outlet of the septic tank should be at different levels.
- ✓ The inlet/outlet should be below the level of foam and above the level of sludge.
- ✓ Baffle or T-junctions should be installed at the inlet/outlet.

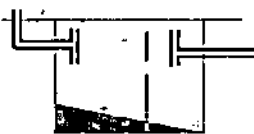

- X Inlet and outlet to be at the same level.
- X Inlet/outlet to be above foam level.
- X Absence of Baffle/T-junction.

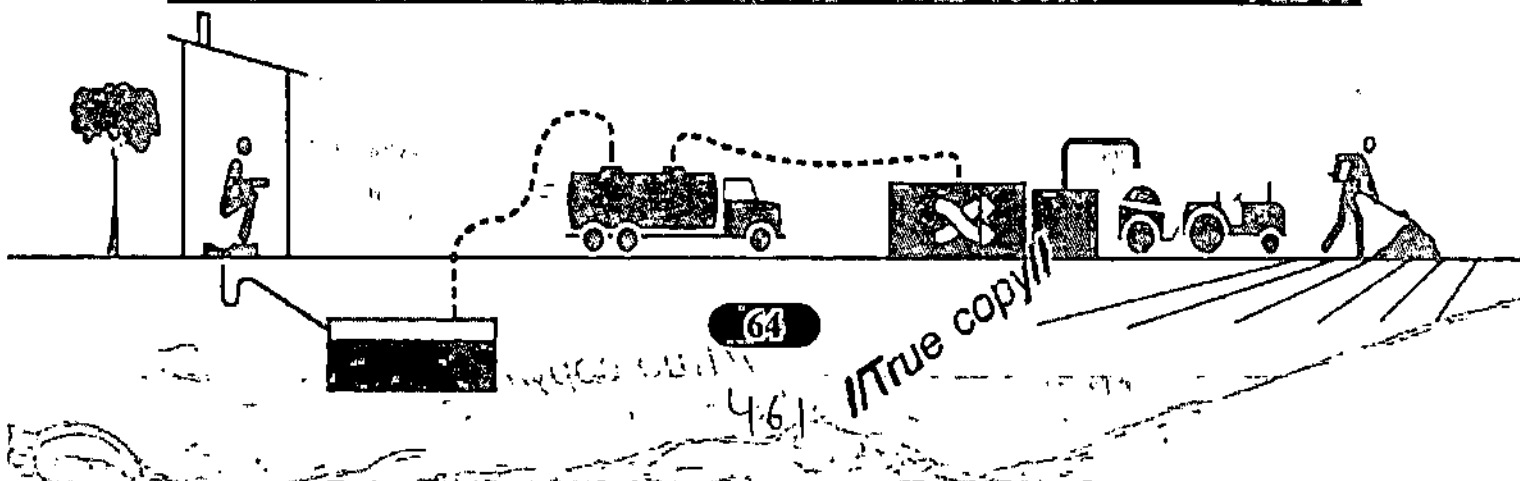

Do's

- ✓ Ventilation pipe should be installed in the septic tank.
- ✓ Mosquito net should be installed in the ventilation pipe.
- ✓ The height of the ventilation pipe should be 2 meters above than the buildings which are up to 20 meters away from the septic tank.

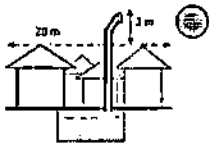

Dont's

- X Non-installation of ventilation pipe in septic tank.
- X Non-instollotion of mosquito net in the ventilation pipe.
- X Do not keep the ventilation pipe shorter than the surrounding buildings.

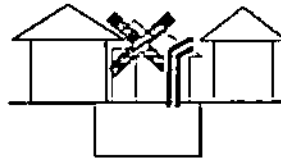

- ✓ The filth water coming out of the septic tank should ga into the blotting pit only.

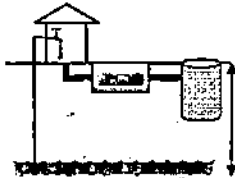

- X The dirty/filth water from the septic tonk should not ga into the drains.

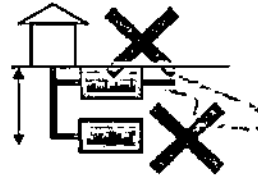

- ✓ Get the septic tank cleaned once in every 3 years by using suction machine with the help of the municipality.







- X Da not clean the septic tank manuolly. Da not enter inside the septic tank. On doing sa, one can be sentence to both jail ond fine.

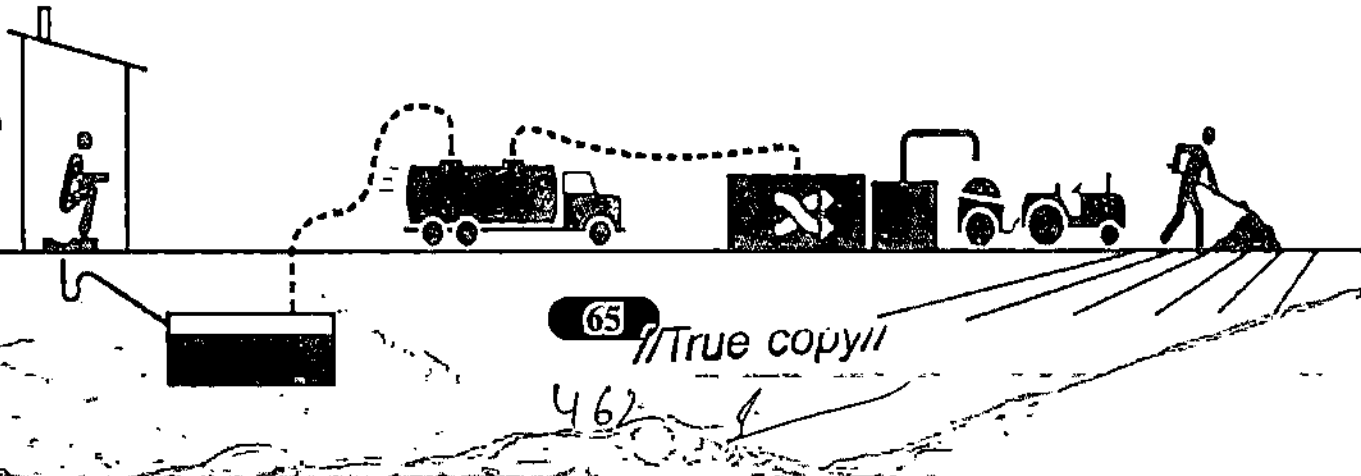

- ✓ Top surface of the septic tank should be cleaned regularly.

- X Da not park the vehicle aver the septic tank and do not plant trees on it.

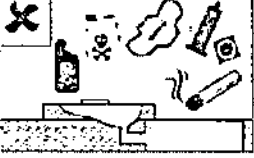

Do's	Dont's
<p>✓ While cleaning the septic tank, the scavengers/Safai Mitra's should wear safety equipment (safety jacket, helmet, mask, hand gloves etc.).</p> 	<p>X Da not clean the septic tank without safety equipment.</p>
<p>✓ Ask the scavengers to leave 2 inches of sludge while cleaning the septic tank.</p> 	<p>X Da not completely empty the septic tank.</p>
<p>✓ The siudge taken out fram the septic tank should be disposed of at the FSTP plant only.</p> 	<p>X Da not dispose of sludge from the septic tank in drains, roadsides or in the forests.</p>
<p>✓ Flaw any sewage and water into the septic tank.</p>	<p>X Da not let acid /chemical / solid waste etc. into the septic tank.</p> 
<p>✓ Welcome and respect the Safai Mitro's.</p>	<p>X Dan't misbehave with the Safai Mitra's.</p>

Source: CEPT University, Ahmedabad

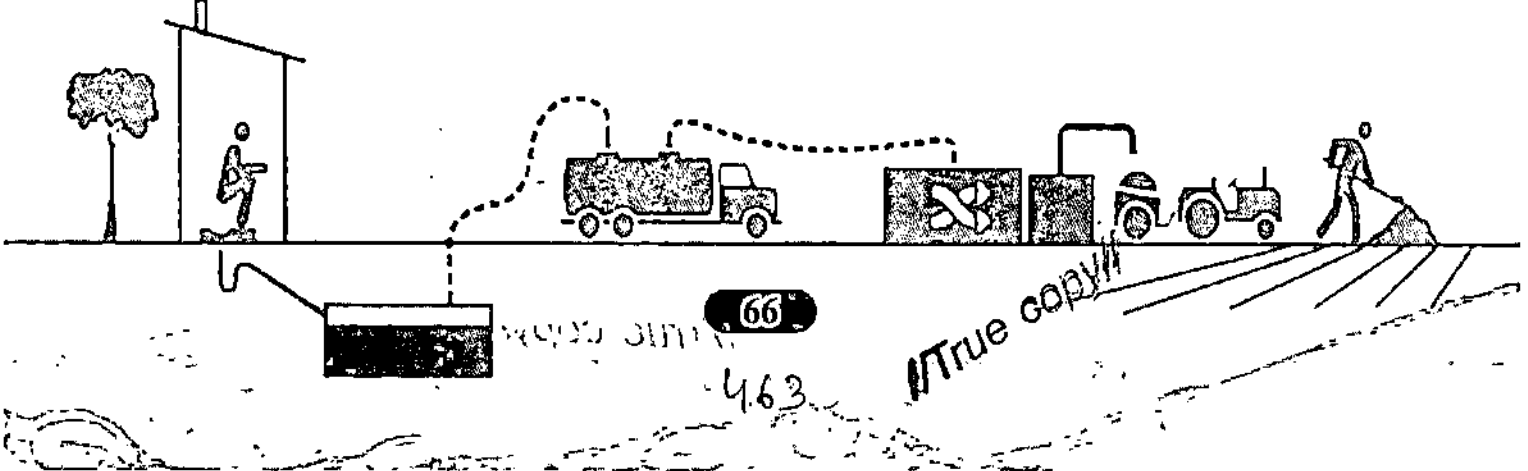

ANNEXURE - III

Sample questionnaire for household survey for regular cleaning of septic tank –

1. Name of the local body -
2. Ward No. -
3. Name of the Respondent -
4. Gender - Male / Female -
5. Mobile Number -
6. Address -
7. Property ID -
8. Caste - SC / ST / OBC / General
9. Building Type - individual Building / Apartment / Commercial Building / institutional Building / Government Building
10. GPS location of the building -
11. Type of house - Kutcha / Semi Pucca / Pucca / Temporary Shelter
12. Poverty Status - APL / BPL / Antyodaya / No Card
13. Do you have toilet in your house - Yes / No
14. Whether the toilet is functional - Yes / No
15. How many members are there in your family (including children)
 - Male –
 - Female –
16. Is your toilet connected to sewer line - Yes / No

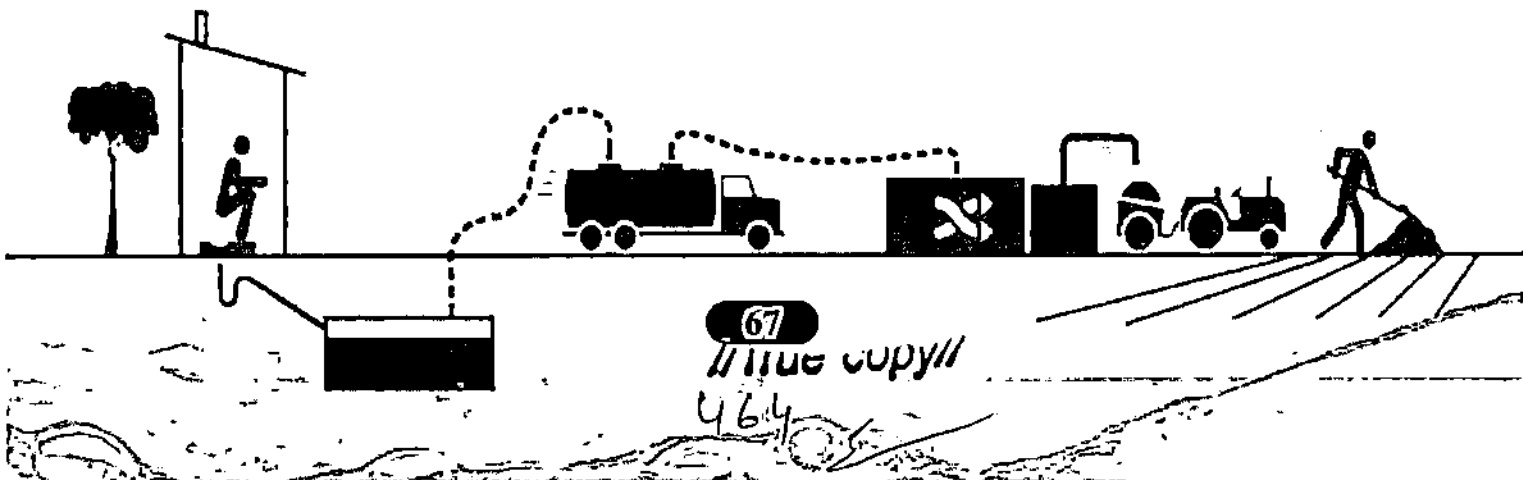

17. What type of toilet is there in your house?

- No toilet
- With septic tank
- Fully concrete pits
- Pit with concrete walls and kutcha surface
- Pit with half concrete walls and kutcha surface
- Leach pit
- All types of pits, which have never been emptied and are left after covering it with mud/soil after getting filled.
- All types of pits, which have never been emptied and are not covered with soil after filling
- Toilet not in good condition, damaged and collapsed due to flood
- All types of pits, which have ruptured and damaged due to floods

18. How is your toilet connected -

- Connected to the main sewer line
- Connected to non-functional main sewer line
- Connected to local sewer line
- Connected to non-functional local sewer line
- Connected with soak pit
- Connected to open drain
- Connected to a pond or river
- Surface water
- Don't aware from where is it connected
- No overflow pipe

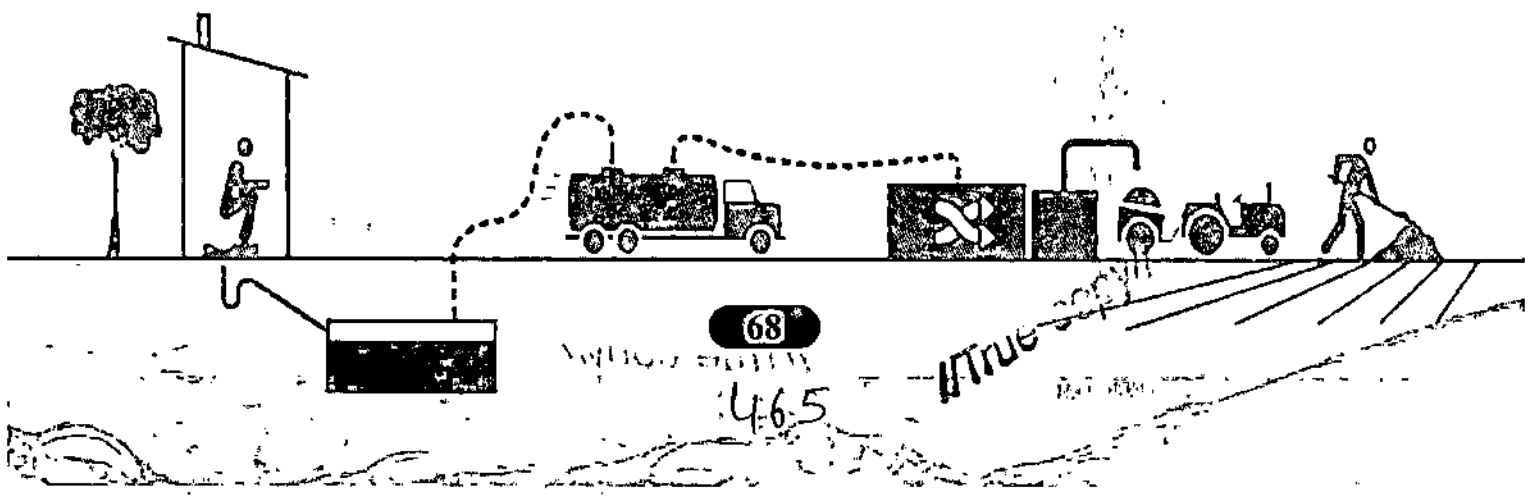

19. Types of toilet tanks -

	Length	Width	Depth
In feet			
In meters			

20. What is the capacity of the toilet tank?

- 1-2 cubic meters
- 3-4 cubic meters
- 5-8 cubic meters
- 9-12 cubic meters
- 13-15 cubic meters
- 16-25 cubic meters
- Over 25 cubic meters

21. What is your toilet type?

- One soak pit
- Piped Twin Saak Pit
- Single pit under seat
- Single pit without concrete surface
- A pit with concrete surface
- ECOSAN composting pit toilet
- Septic tank - two chambers and a soak pit
- Toilet attached with bio-gas
- None of these

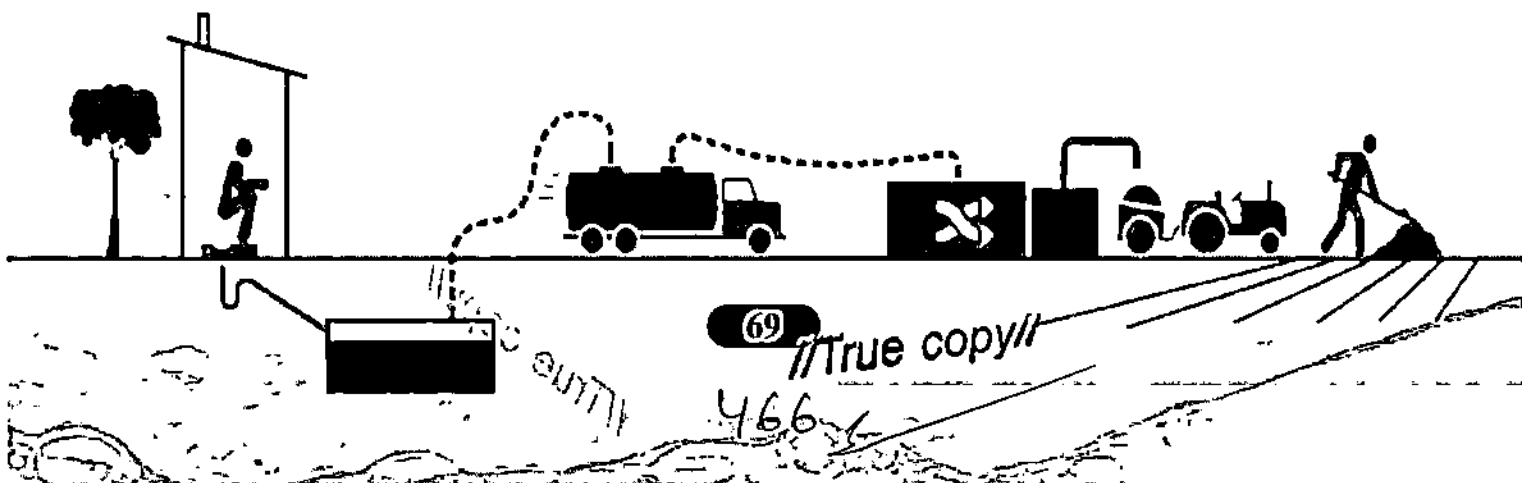

- Don't know
22. When was the tank construct -
23. Has the tank ever been emptied?
- Yes
 - No, it's not full yet
 - No, it's new
24. How many times has the tank or pit been emptied since it was constructed?
- One time
 - Two times
 - More than 2 times
25. When was the tank emptied last time -
26. How the tank was emptied last time -
- Manual cleaning by sweeper
 - Cleaned through suction machine by sweeper
 - By using both
27. What amount did you pay for emptying the tank -
28. What is ground water level -
- Less than 5 meters
 - 5-10 meters
 - more than 10 meters
29. Is there any underground water source located within 10 meters from the tank -
Yes/No
30. What is the source of drinking water in your house?
- Safe bore / tube well / hand pump

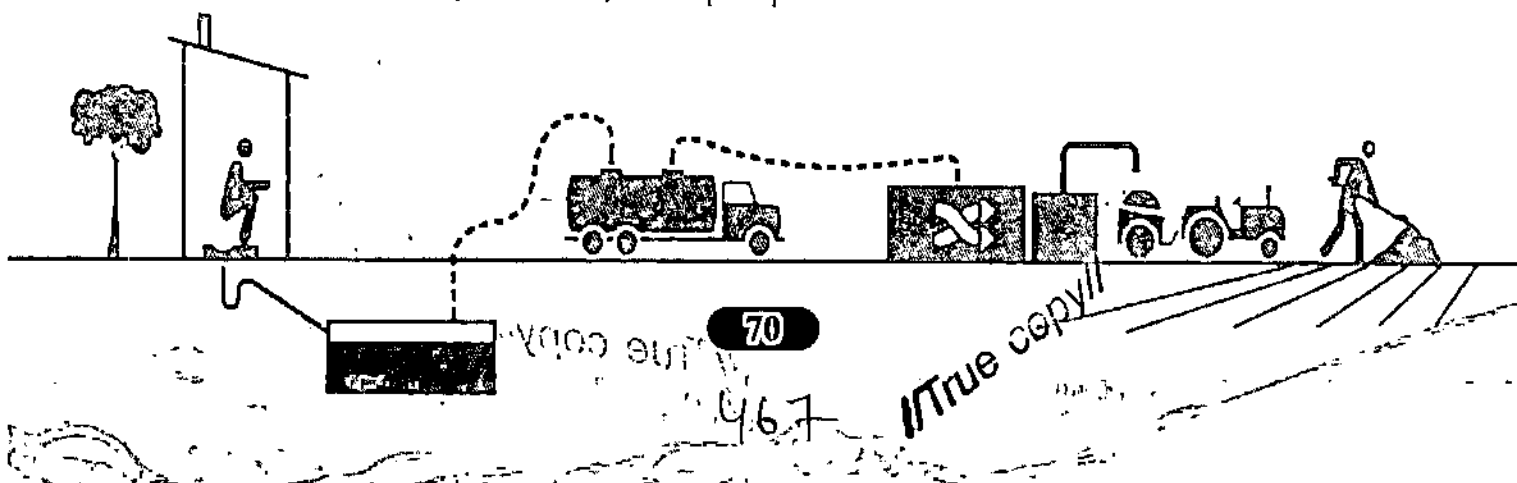

- Unsafe bore / tube well / hand pump
- Safe well
- Pipe connection with underground water
- Pipe connection with surface water
- Pond or river
- Spring

31. What is the width of the road in front of the building?

32. Whom do you contact first for emptying the septic tank -

- Local sweeper/group
- Local body
- Contact at the call center of Nagar Panchayat / Municipality
- Contact the truck operator directly
- Don't know

33. Do you know about the specific period for emptying the septic tank / pit -

- Yes, the information is correct - every 3 years
- No, wrong information
- No information

34. From where do you get information regarding regular emptying of the pit / septic tank?

- Media (TV, Newspaper, Radio etc.)
- interpersonal communication (household visits, community meetings, etc.)
- Mass Communication (Miking, Video Promotion, Wall Painting etc.)
- None of the above (No information)

35. Have you seen the sweeper using the safety kit while emptying the pit or tank?

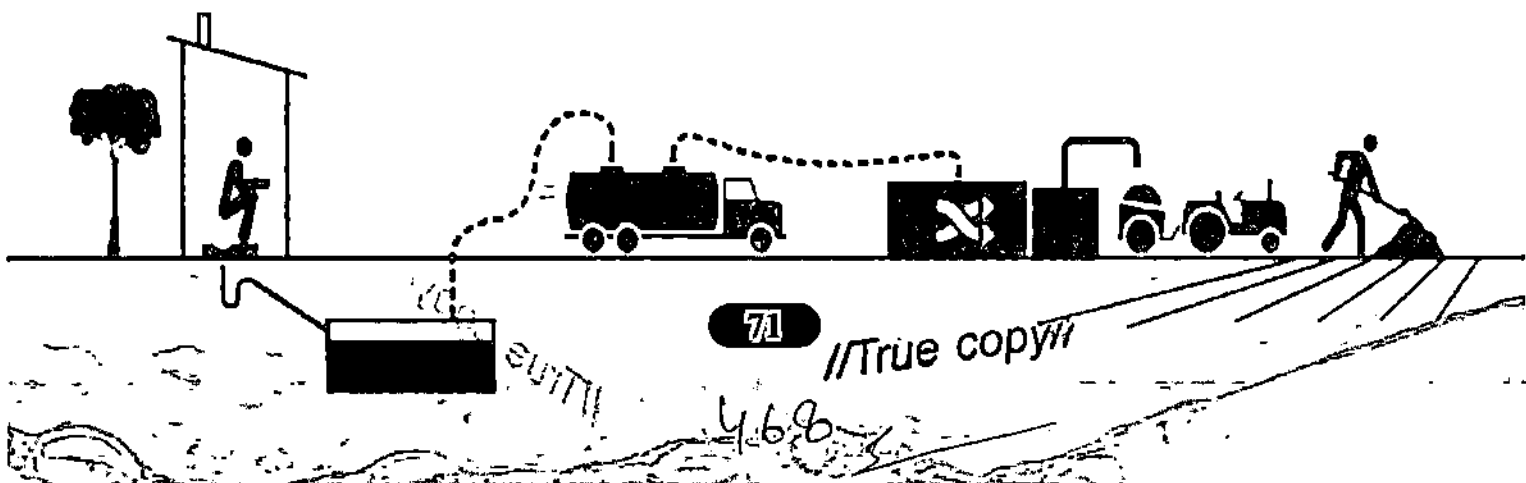

- Yes
- No
- Do not know

36. Do you know where the sludge taken out from the pit is being dump?

- In open areas such as pond, forest, river etc.
- In sewage network
- in Treatment Plant (FSTP)
- Don't know

37. Does the sewage water coming out of the toilet pit bothered you -

- Yes
- No

38. Who according to you is responsible for the safe disposal of sewage from septic tank and pit?

- Household
- Community
- Municipality

39. If your tank is emptied every 3 years, would you be willing to pay a regular fee to the entity local body-

- Yes
- No

40. How much amount would you like to give per round?

41. How easy is it to empty your toilet tank -

- Tank has lid
- Tank is fully packed and needs to be broken to empty
- The tanker emptying the tank cannot reach up to the tank

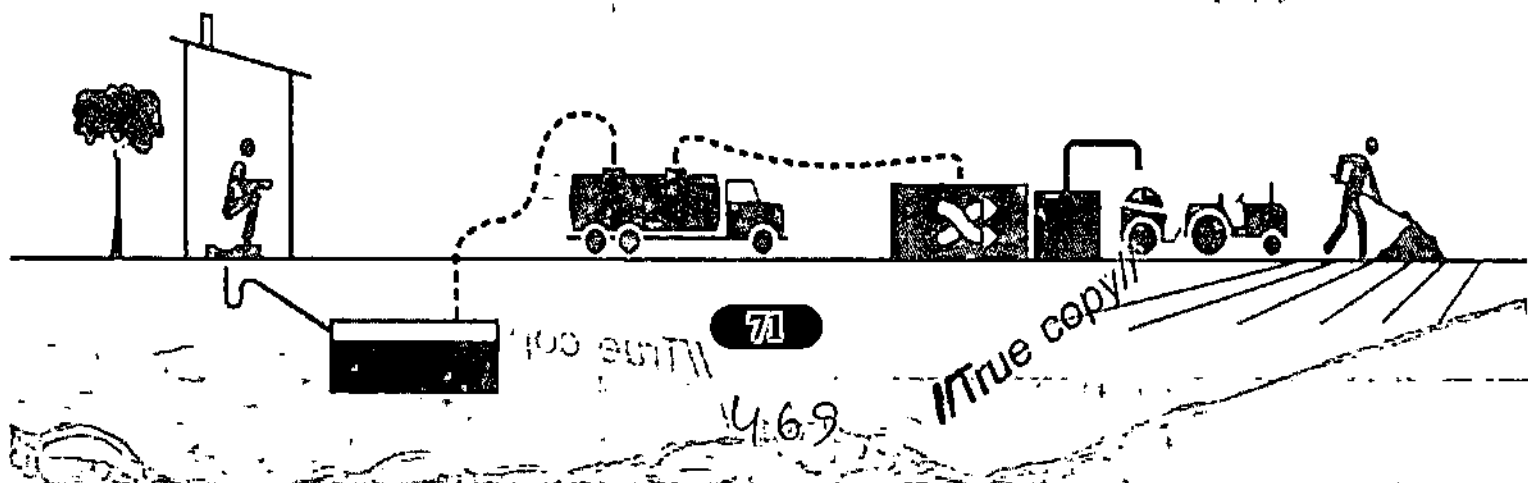

ANNEXURE - IV

Daily Reporting:

Date of Desludging	Resident Name	Mobile Number	Address	Quantity of Septage (Liters)	No. of trips	Total volume of Septage (Liters)	Vehicle Type and Capacity	Did the cover of septic tank fixed properly	Other

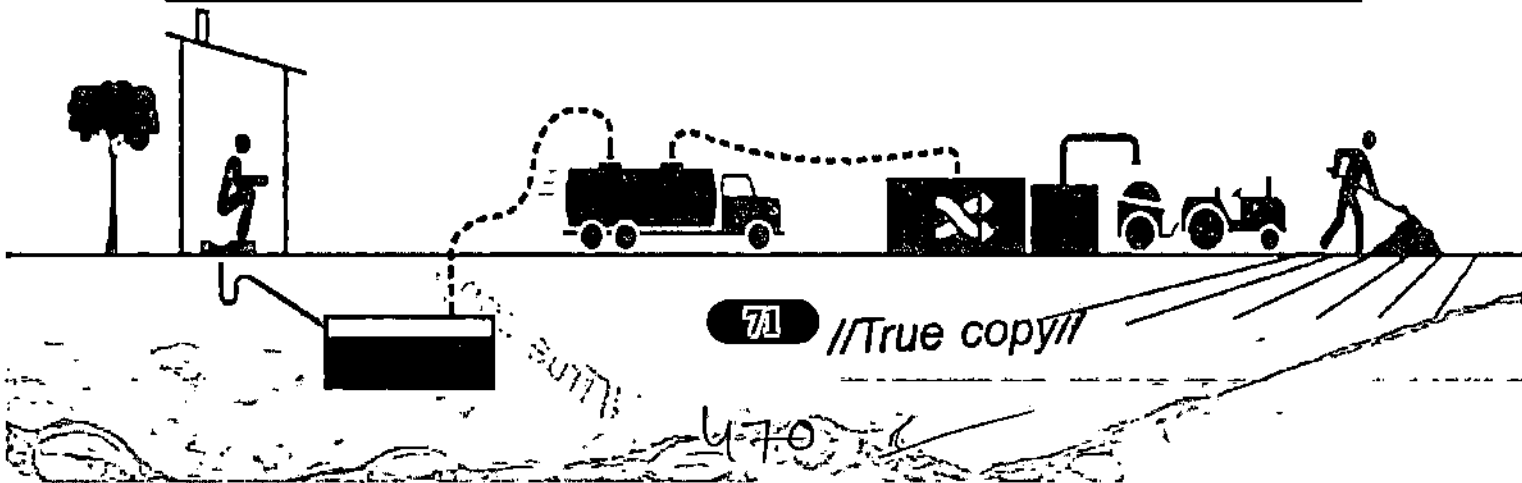

ANNEXURE - V

Form to be filled during desludging of septic tank

1. Name:
2. Mobile Number:
3. Address:
4. Property ID:
5. Type of Property: Individual Household/Apartment/ Commercial Complex/School/Government Office/Public Toilet/Community Toilet/Other
6. Did you open the Septic tank cover? Yes/No
7. Did you break the septic tank cover? Yes/Na
8. Type of Tank:
 - One Leach Pit
 - Twin Leach Pits
 - Single Pit below the toilet sheet
 - Single tank with open bottom
 - Single tank with concrete bottom
 - EcoSan toilet
 - Septic tank – 2 chambers with one soak pit
 - Biogas toilet
 - Other. Specify.....

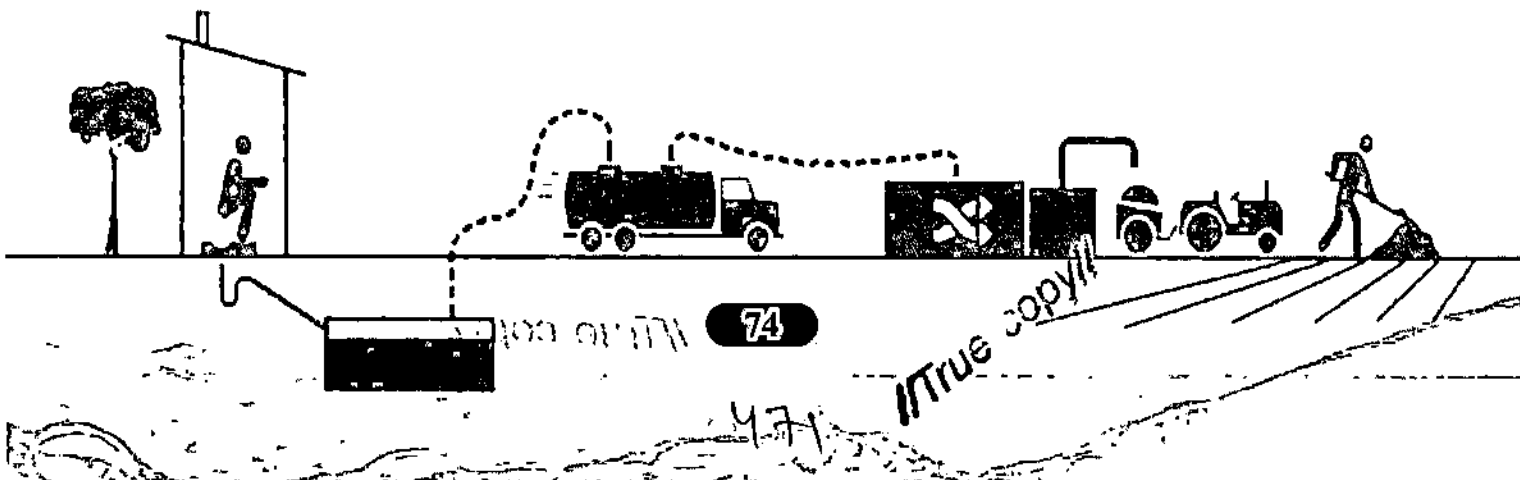

- 9. Amount of sludge (in liters)
- 10. Has the septic tank cover been placed again? Yes/No
- 11. Any Problem/defects encountered – pipe not available, manhole at the wrong place, any form of cracks or damage observed, vent pipe availability

I, the person signing below, declare that the details mentioned above are true and my septic tank has been cleaned.

Date.....

Signature

Time.....

- 12. Emptying Operator's name
- 13. Permit Number
- 14. License Number
- 15. Capacity of truck.....in litres
- 16. Date of cleaning of septic tank.....
- 17. Number of trips done to clean the septic tank.....

The above-described septic tank has been cleaned by me and the collected septage has been transported to the address mentioned below. I affirm that these mentioned details are true.

Driver's Name

Signature

Mobile Number

Truck Number

Receipt from the official of Faecal Sludge Treatment plant's supervisor

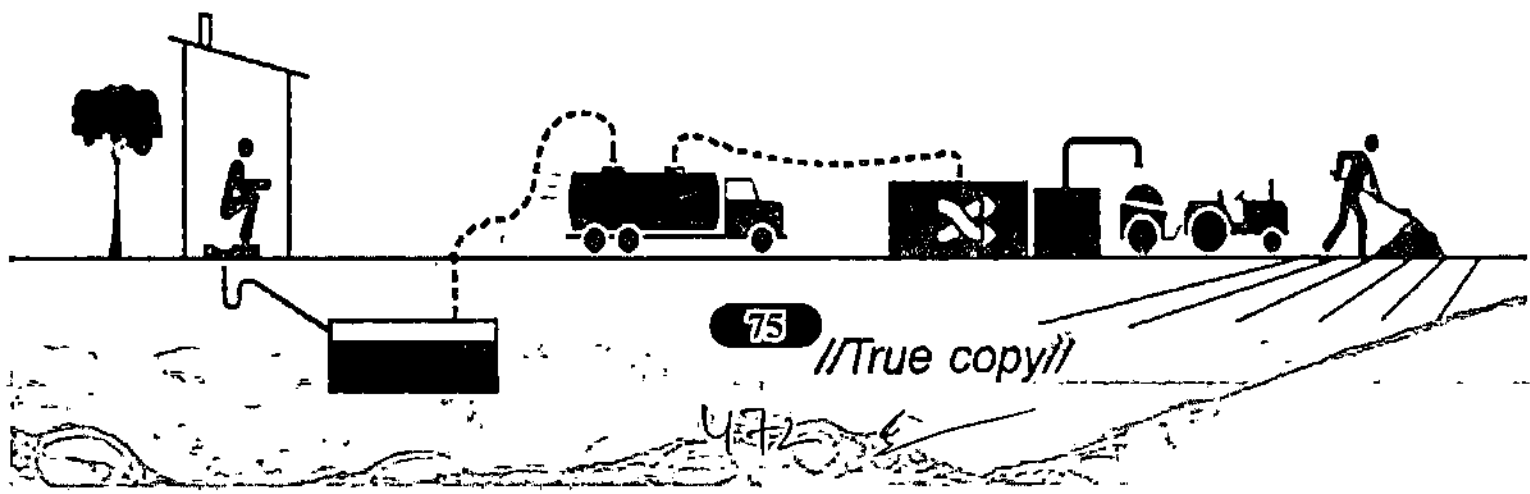

Desludging truck operator has disposed the collected septage at our facility.

- 18. Was there any debris/rubbish found in the disposed septage? Yes/No
- 19. How many trips were required to transport septage from the above mentioned septic tank to the treatment plant:.....
- 20. Date of disposal of this septage at the treatment plant:
Time
- 21. Quantity of sludge (in liters)

Name of the FSTP plant operator/supervisor

Signature

Mobile Number

Date

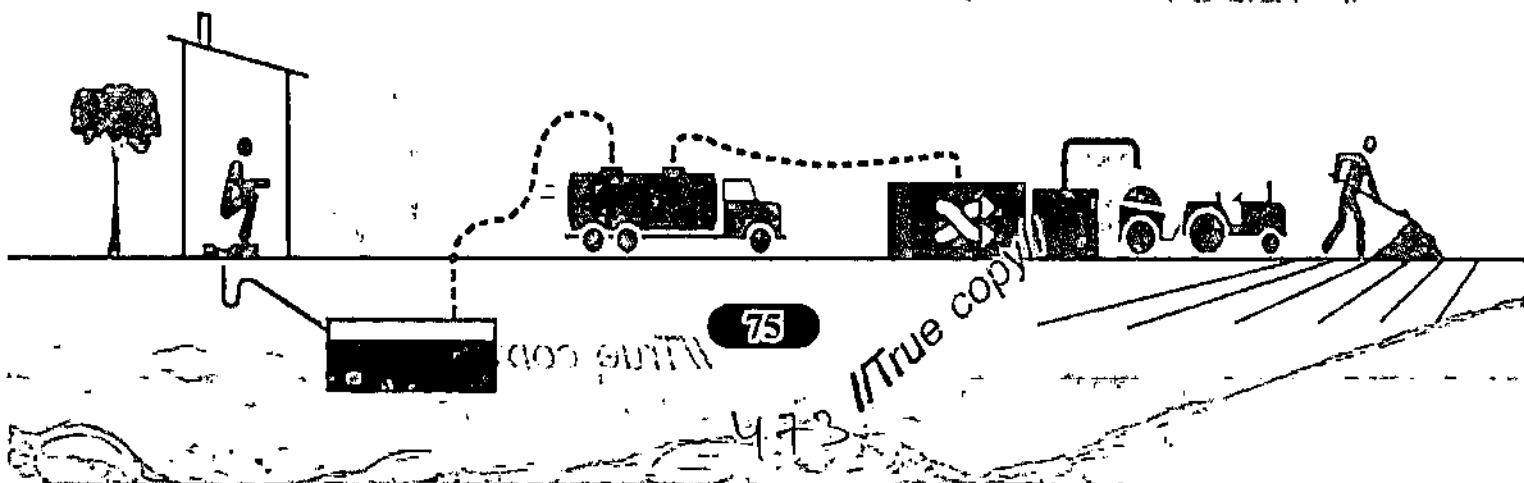

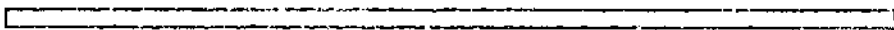

ANNEXURE - VI

Checklist before cleaning Sewer lines				
1	Did you barricade the area of work?	Yes	<input type="checkbox"/>	No <input type="checkbox"/>
2	Have you opened upstream and downstream machine holes?	Yes	<input type="checkbox"/>	No <input type="checkbox"/>
3	Is there a regular overflow?	Yes	<input type="checkbox"/>	No <input type="checkbox"/>
4	What kind of area is it?	Commercial	<input type="checkbox"/>	Residential <input type="checkbox"/>
5	Does the worker have the safety equipment's?	Yes	<input type="checkbox"/>	No <input type="checkbox"/>
6	Has the worker applied oil?	Yes	<input type="checkbox"/>	No <input type="checkbox"/>
7	Is the sewage cleaning machine available?	Yes	<input type="checkbox"/>	No <input type="checkbox"/>
8	Is the suction of the cleaning machine verified?	Yes	<input type="checkbox"/>	No <input type="checkbox"/>
9	If yes, is it in good condition?	Yes	<input type="checkbox"/>	No <input type="checkbox"/>
10	Has the stagnant sewage water been cleared from the overflowing machine hole?	Yes	<input type="checkbox"/>	No <input type="checkbox"/>

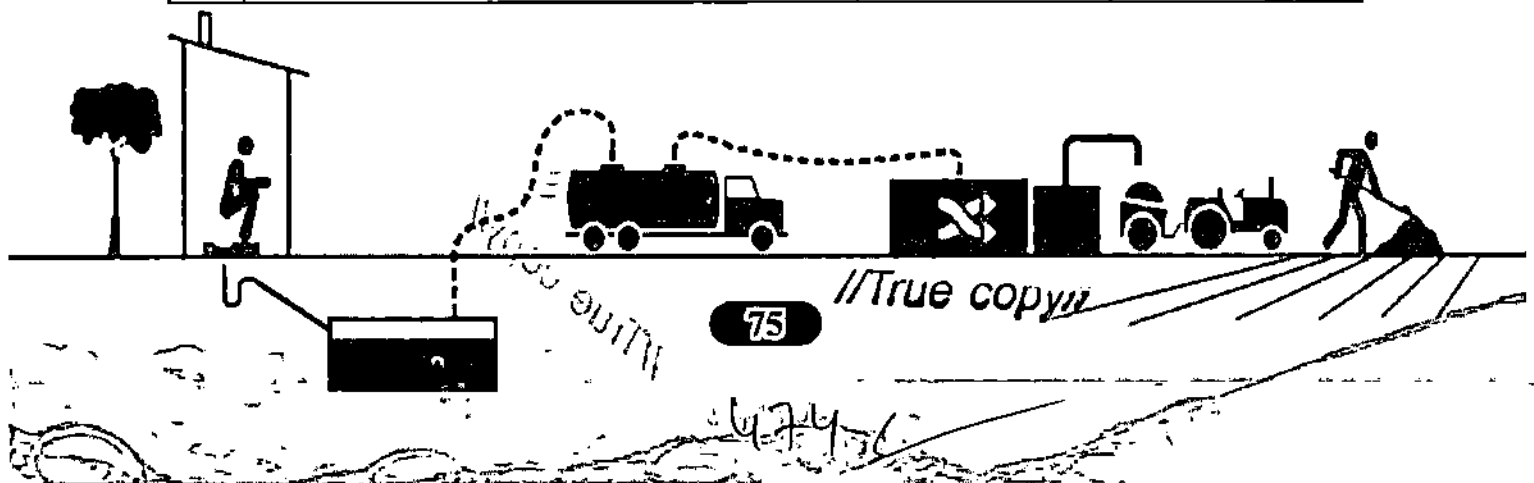

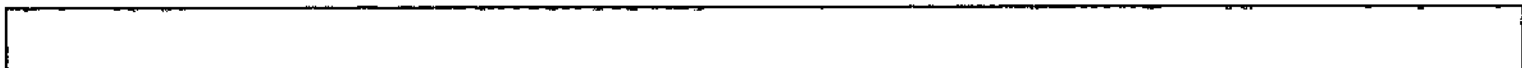

Checklist before cleaning Sewer lines

11	Is the health condition of the worker acceptable?	Yes <input type="checkbox"/>	No <input type="checkbox"/>
12	Are the pipelines silted?	Yes <input type="checkbox"/>	No <input type="checkbox"/>
13	Where is the chockage?	Machine hole <input type="checkbox"/>	Pipeline <input type="checkbox"/>
14	Is there an Oxygen Cylinder?	Small Cylinder <input type="checkbox"/>	External Cylinder <input type="checkbox"/>
15	If yes, choose the appropriate option:	Pipe leading to Machine hole <input type="checkbox"/>	No <input type="checkbox"/>

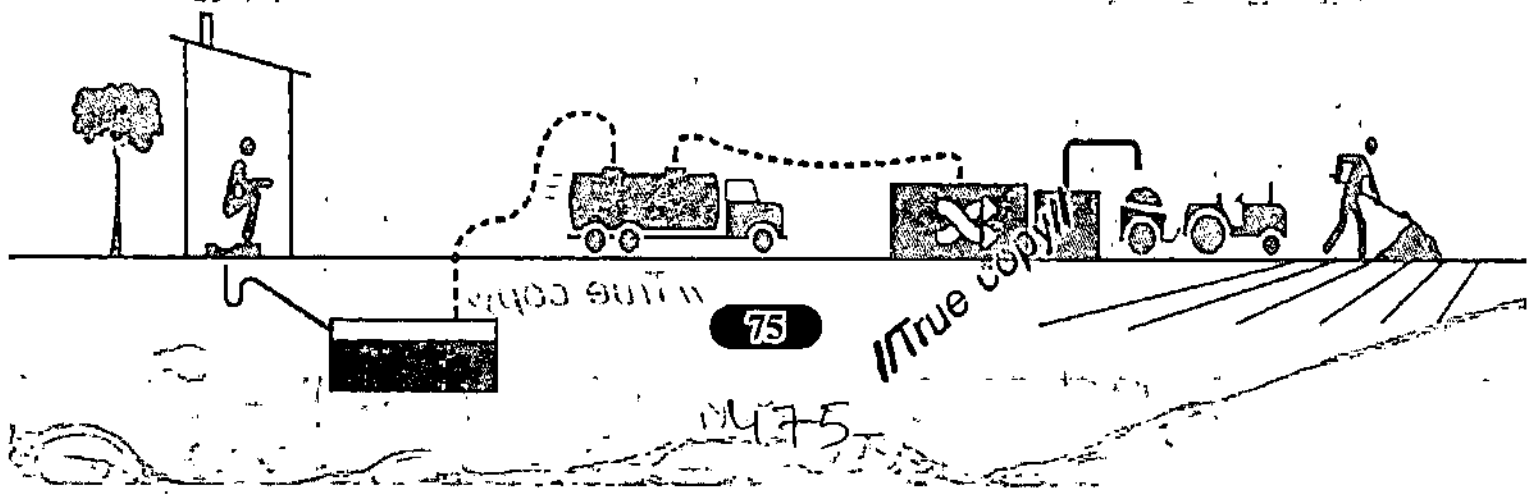

ANNEXURE - VII

Checklist for Entering Machine bole			
Depth < 2m		Depth > 2m	
Checklist	Yes/No	Checklist	Yes/No
I. Personal Safety Kit		I. Personal Safety Kit	
Helmet with headlight		Helmet with headlight	
Gum Boots		Gum Boots	
Waterproof Clothing		Waterproof Clothing	
Gloves		Gloves	
Safety Belt		Safety Belt	
Oxygen Mask		Oxygen Mask	
Chemical Cartridge Mask		Chemical Cartridge Mask	
Oil		Oil	
Soap		Soap	
Towel		Towel	
Oxygen Cylinder		Oxygen Cylinders	

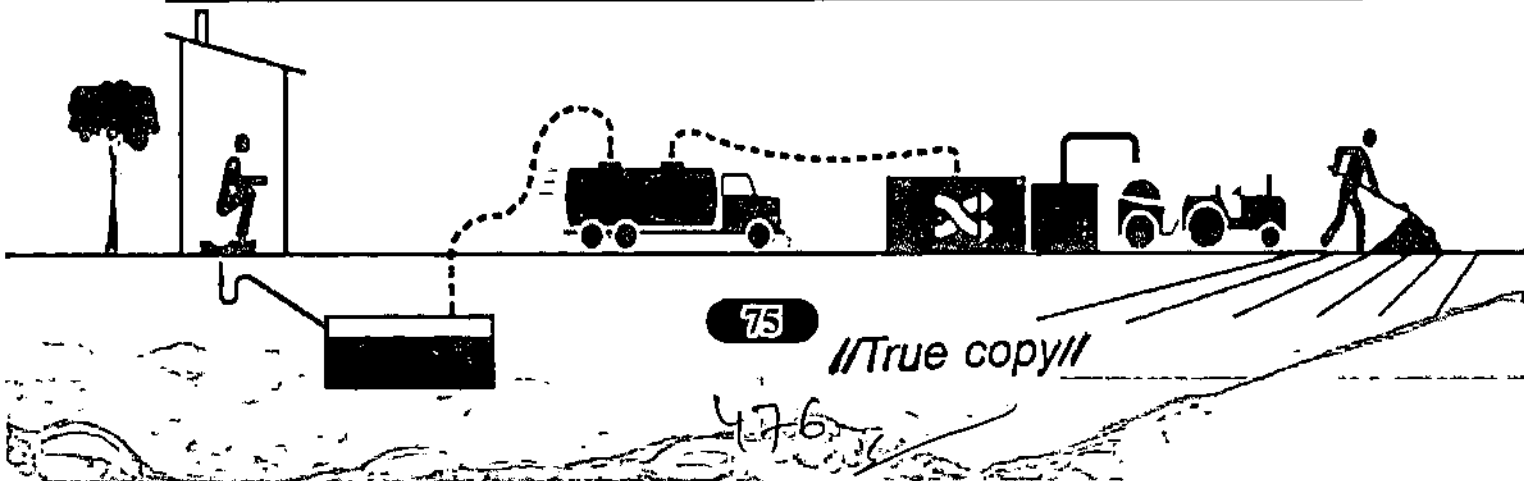

Checklist for Entering Machine hole			
Depth < 2m		Depth > 2m	
Checklist	Yes/No	Checklist	Yes/No
2. Kit for the team of sanitation workers		2. Kit for the team of sanitation workers	
Barricade		Barricade	
Rope Ladder/Tripod with Chain Pulley		Tripod with Chain Pulley	
Silt Grabber		Silt Grobber	
Chromo-flexible Steel Rod		Chromo-flexible Steel Rod	
Bucket with Rope		Bucket with Rope	
Spade with long handle		Spade with long handle	
Crowbar		Crowbar	
Trolley		Trolley	
First Aid Kit		First Aid Kit	
Machine hole Key Rod		Machine hole Key Rod	

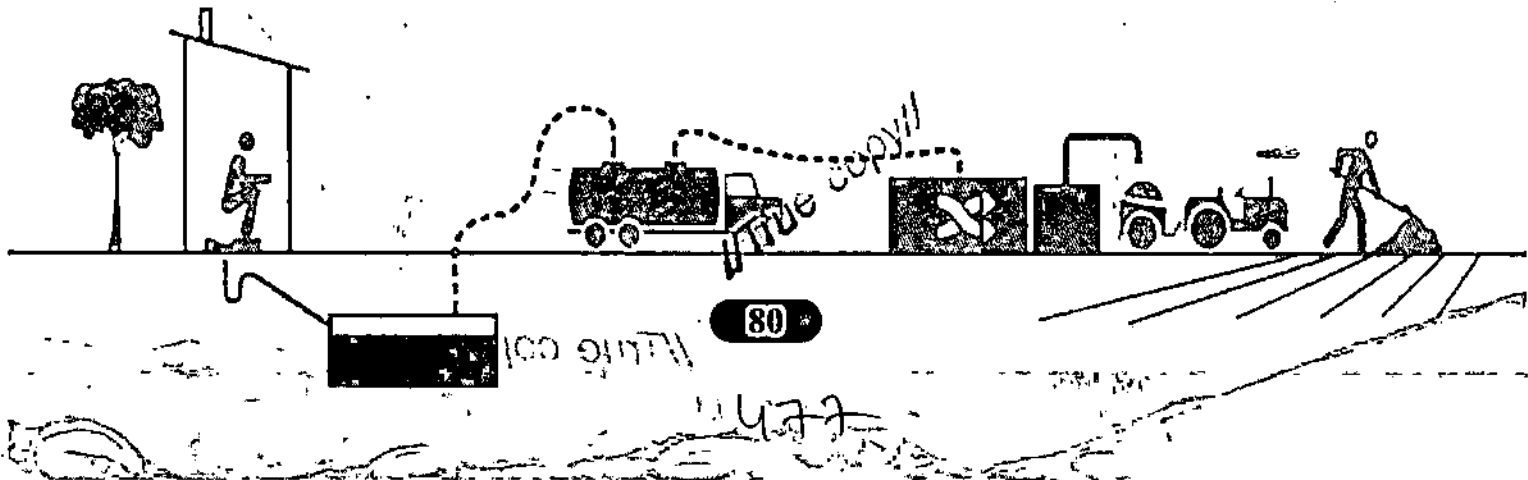

ANNEXURE - VIII

Checklist for Minimum constituents of the first aid kit that shall be made readily available to the staffs employed in sewer cleaning at the site.

No.	Checklist	Minimum Constituents	Yes
1	Small, sterilized dressings.	6	<input type="checkbox"/>
2	Medium size sterilized dressings	3	<input type="checkbox"/>
3	Large size sterilized dressings	3	<input type="checkbox"/>
4	Large, sterilized burn dressings	3	<input type="checkbox"/>
5	Bottle (30ml) containing a two percent alcoholic solution iodine	1	<input type="checkbox"/>
6	Bottle (30 ml) containing Sal volatile having the dose & mode of administration indicated on the label	1	<input type="checkbox"/>
7	Snakebite lancet	1	<input type="checkbox"/>
8	Bottle (30 gm) of potassium permanganate crystals	1	<input type="checkbox"/>
9	Pair scissors	1	<input type="checkbox"/>
10	Copy of the first-aid leaflet issued by the Director General Factory Advice Service and Labour institutes Government of India.	1	<input type="checkbox"/>
11	Bottle containing 100 tablets (each of 5 gm) of aspirin	1	<input type="checkbox"/>
12	Ointment for burns		<input type="checkbox"/>
13	Bottle of suitable surgical antiseptic solution	1	<input type="checkbox"/>

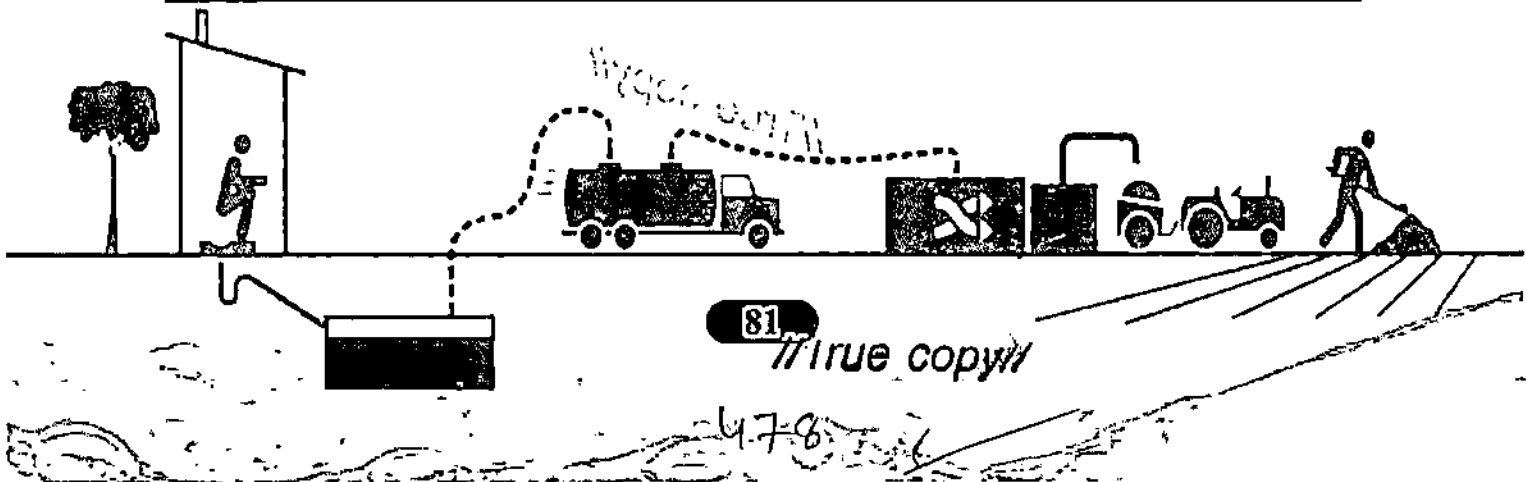

REFERENCES

- Swachh Bharat Mission -Urban, (2020). Equipment & Workforce Norms for Managing Waterborne Sanitation in India.
www.swachhbharaturban.gov.in | www.cpheeo.gov.in
- Handbook for Sanitation Workers on use of Personal Protective Equipment. (n.d.).
www.umcasia.org
- Ministry of Housing and Urban Affairs Government of India Standard Operating Procedure (SOP) for Cleaning of Sewers and Septic Tanks. (2018).
www.amrut.gov.in
<http://cpheeo.gov.in/upload/5c0a062b23e94SOPforcleaningofSewersSepticTanks.pdf>
- Safalmitra Suraksha Challenge City Challenge on Man-hole to Machine-hole Transformation National Competition. (n.d.).
<https://safalmitrasurakshachallenge.org/>
- Septic Tank- Dos and Don'ts Poster
<https://www.pas.org.in/Portal/document/UrbanSanitation/uploads/Poster-Septic%20tanks%20dos%20and%20dnts.pdf>
- SOP for desludging of septic tanks, Standard Operating Procedures for Desludging of Septic Tanks. (2020).
https://pas.org.in/Portal/document/UrbanSanitation/uploads/SOP_for_desludging_septic_tank.pdf
- Swachh Bharat Mission-Urban 2.0 Making Cities Garbage Free Operational Guidelines. (2021).
<https://sbmurban.org/storage/app/media/pdf/swachh-bharat-2.pdf>
- Technical and managerial Interventions for Ensuring Safety during Sewer and Septic Tank Cleaning Emergency Response Sanitation Unit (ERSU) Ministry of Housing and Urban Affairs. (n.d.).
https://niu.org/scbp/sites/default/files/Advisory_on_Emergency_Response_Sanitation_Unit_0.pdf

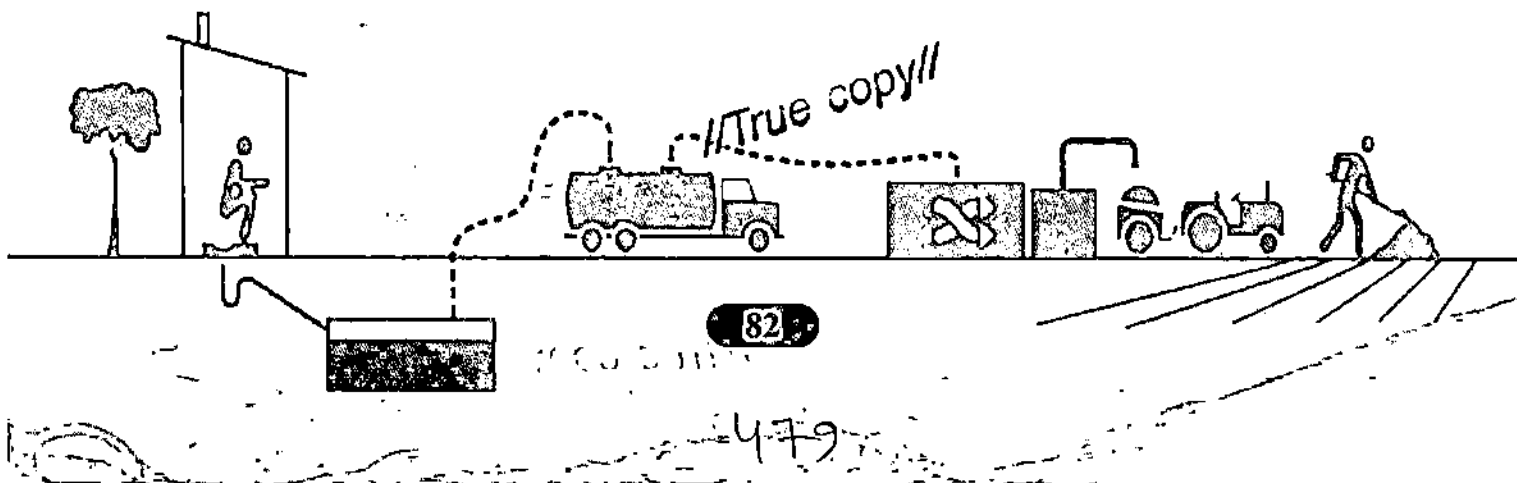

आजादी का
अमृत महोत्सव

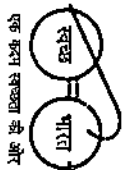

1960

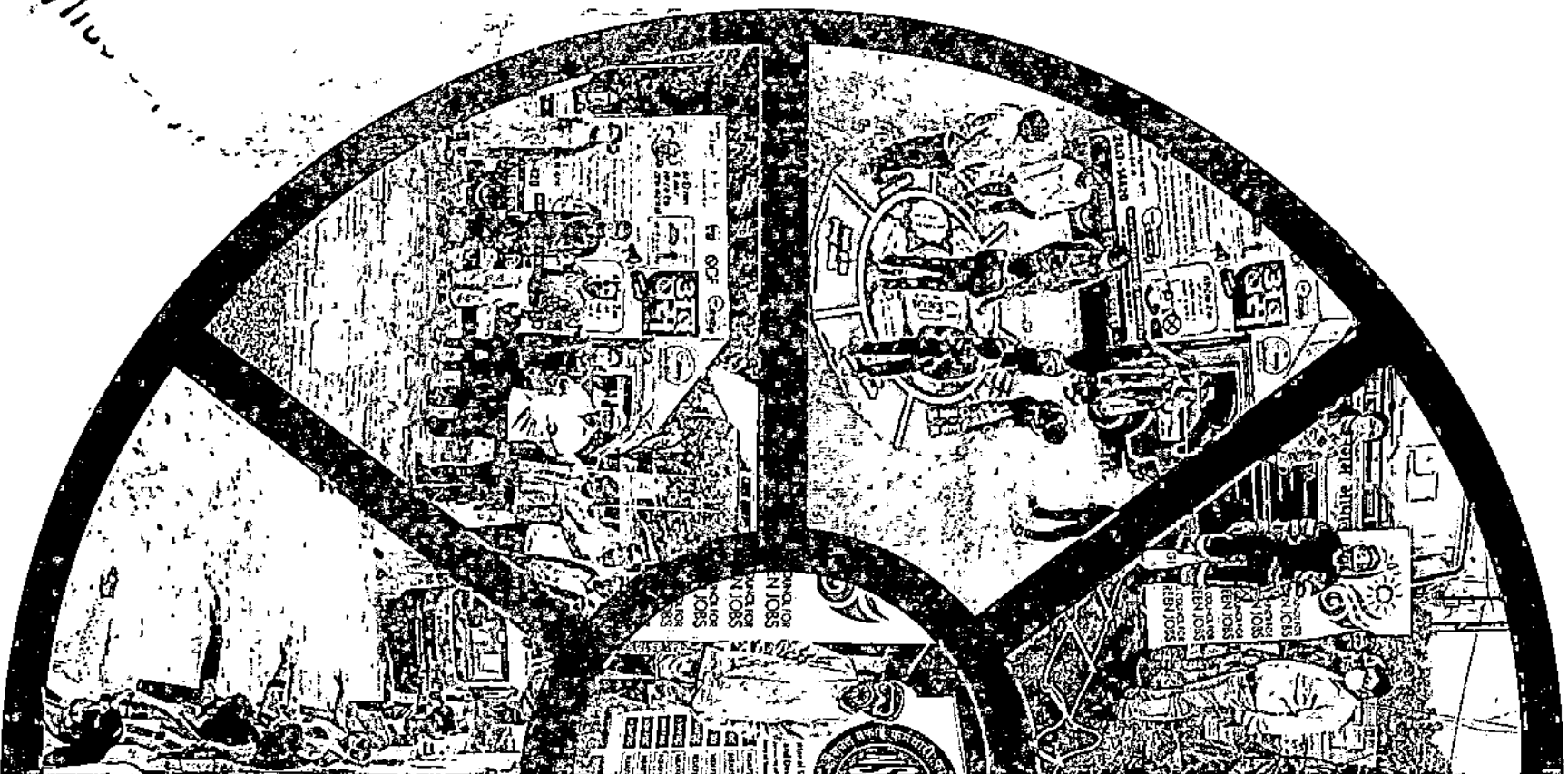



संचालनालय, नगरीय प्रशासन एवं विकास, म.प्र., भोपाल
Directorate, Urban Administration & Development, M.P., Bhopal

Palika Bhawan, Near 6 No. Bus Stop,
Shivaji Nagar, Bhopal - 462016
Tel. 0755-2554083, Fax 0755-2550294
Email:- neelsh@mpurban.gov.in
Website: www.mpurban.gov.in

क्रमांक- मु.श.स्व.मि./2015-16/8340

भोपाल दिनांक 12/11/15

प्रति,

1. समस्त आयुक्त,
नगर पालिक निगम,
मध्यप्रदेश।
2. समस्त मुख्य नगर पालिका अधिकारी,
नगर पालिका परिषद / नगर परिषद
मध्यप्रदेश।

विषय :- सेप्टिक टैंक/सीवर लाईन सफाई में मृत कर्मियों को क्षतिपूर्ति प्रदान करने के संबंध में।

संदर्भ :- माननीय सर्वोच्च न्यायालय द्वारा प्रकरण क्रमांक 583/2003 सफाई आंदोलन एवं अन्य विरुद्ध भारत सरकार

विषयान्तर्गत लेख है कि माननीय सर्वोच्च न्यायालय द्वारा दिये गये निर्देश के अनुक्रम में वर्ष 1993 के पश्चात् सेप्टिक टैंक/सीवर लाईन सफाई में मृत कर्मियों को रु. 10.00 लाख क्षतिपूर्ति प्रदान किया जाना है।

राज्य में "हाथ से मैला उठाने वाले कर्मियों के नियोजन का प्रतिषेध एवं उनका पुनर्वास अधिनियम-2013" अधिनियम लागू है। अधिनियम के विहित प्रावधानों की धारा -3 से 8 तक विहित प्रावधानों के अनुसार आवश्यक सुरक्षा उपकरणों के साथ ही सेप्टिक टैंक या सीवर लाईन सफाई में किसी कर्मियों को नियोजित किया जाये।

उपरोक्त सुरक्षा प्रावधानों के पश्चात् भी किसी कर्मियों की सीवर लाईन/सेप्टिक टैंक सफाई के दौरान आकस्मिक मृत्यु होने पर संलग्न प्रपत्र अनुसार जानकारी तैयार कर तत्काल क्षतिपूर्ति राशि हेतु संचालनालय को प्रेषित किया जाये।

उपरोक्त निर्देश समस्त नगरीय निकायों में स्थाई रूप से लागू होंगे।

संलग्न :- उपरोक्तानुसार

आयुक्त,

नगरीय प्रशासन एवं विकास,
भोपाल

// true copy //

482

www.rajasthan.gov.in

TRUE COPY

भारत
राज्य प्रशासन एवं विकास

अधिसूचना

- 1- समस्त कलेक्टर, मध्यप्रदेश।
- 2- मुख्य अभियंता/अधीनस्थ, नदीय प्रशासन एवं विकास, भारत।
- 3- समस्त महोदय/अध्यक्ष, नगर पालिका निगम/नगर पालिका परिषद/नगर परिषद।
- 4- समस्त संभागीय उप संचालक, नदीय प्रशासन एवं विकास, मध्यप्रदेश।
- 5- संभागीय अधीक्षण यंत्री/कार्यपालन यंत्री, नदीय प्रशासन एवं विकास, मध्यप्रदेश।
- 6- समस्त परियोजना अधिकारी, जिला सहायी विकास अधिकरण, मध्यप्रदेश।

प्रतिनिधि :-

पं. क्रमांक-मु.शा.स्व.नि./2015-16/5341

भारत दिनांक 12/6/15

11/11/11

483

सत्यापनकर्ता अधिकारी का पदस्थिति का विवरण

आई.एफ.एस. कोड

शाला कक्षाक

शाला का नाम

बुक का नाम

उत्तराधिकारी का वर्णित बुक शाला का विवरण

9

पता
इलाहाबाद/अजमेरा

2) नाम
आई.डी. पी. क्र.

पता
इलाहाबाद/अजमेरा

1) नाम
आई.डी. पी. क्र.

अवकाश

उत्तराधिकार सत्यापन करने हेतु शाला
आई.डी. एवं पता सहित)

उत्तराधिकारी का अंतक से संबंध
(लिखित पर पंजीयत अधिलक्ष हो)

उत्तराधिकारी का नाम
(लिखित संलग्न करें)

अंतक के संबंध में प्रथम सूचना प्रतिवेदन कक्षाक
(सत्यापित लिखित संलग्न करें)

अंतक का अंतक प्रमाण-पत्र कक्षाक

अंतक के पंजीयत में सत्यापन की संख्या

काई आरि)

2) (आधार काई/वॉल्ट आई.डी. काई/समाप्त आई.डी./शाला

अंतक का फोटो पहचान पत्र कक्षाक

1) अंतक का नाम

सर्विक टैक/सीपर लॉडन सफाई में अंत कक्षाक को वर्णित हेतु
पृथक

10 (नगर निगम की दशा में स्वास्थ्य अधिकार/ नगर पालिका एवं नगर परिषद् की दशा में मुख्य नगरपालिका अधिकारी)

11 अनुशासकता अधिकारी का नाम
(संभागीय उपसंचालक)

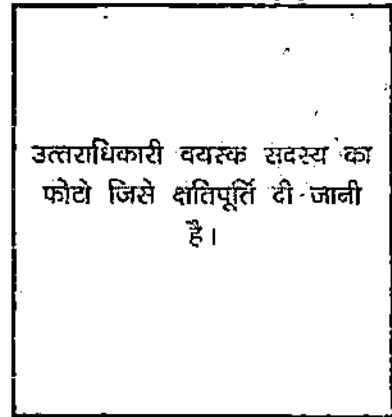
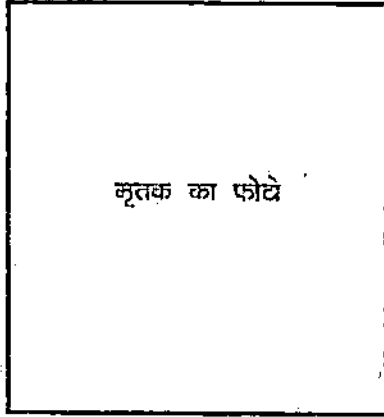

टीप :- उपरोक्त कथन को सिद्ध करने वाले दस्तावेज कमशः संलग्न करें।

हस्ता./
सत्यापनकर्ता अधिकारी
(नगर निगम की दशा स्वास्थ्य अधिकारी एवं
नगर पालिका परिषद्/नगर परिषद् की दशा में
मुख्य नगरपालिका अधिकारी)

हस्ता./
अनुशासकता अधिकारी
(आयुक्त, नगर निगम की दशा तथा
नगर पालिका परिषद्/नगर परिषद् की
दशा में संभागीय उपसंचालक)

//True copy//

484

Annexure - IV - V
355/8

GOVERNMENT OF NATIONAL CAPITAL TERRITORY OF DELHI
DEPARTMENT FOR THE WELFARE OF SC/ST/OBC
'B'-BLOCK, IIND FLOOR, VIKAS BHAWAN,
I.P. ESTATE, NEW DELHI 110002.

F.NO. 28(55)/2023/DSCST/P&G./Pt.file-II /12392-96 DATE: 29/01/2024

To,

Sh. S. B. Prasad,
Under secretary, Government of India,
Ministry of Social Justice & Empowerment,
B2 Ground Floor,
Pt. Deendayal Antyodaya Bhawan,
C.G.O Complex, New Delhi 110003

Sub: Submission of Compliance Report in R/o 14 Points Directions issued by Hon'ble Supreme Court in the matter of Dr. Balram Singh Vs Union of India and Ors in PIL Case WPC 324/2020-reg.

Sir,

Please refer to VC meeting held on 05.01.2024 under the chairmanship of Economic Advisor regarding implementation of NAMASTE Scheme and discuss the Status of implementation of Hon'ble Supreme Court Judgement dated 20.10.2023 in WPC no. 324 of 2020 filed by Dr. Balram Singh Vs Union of India and others.

In this regard, the Department for the Welfare of SC/ST/OBC, GNCTD has issued following Notifications/Orders in respect of the directions, (Point no. 12) issued by the Hon'ble Supreme Court in the matter of Dr. Balram Singh Vs Union of India and others, WPC no. 324 of 2020 vide dated 20.10.2023.

1. Notification issued for constitution of Delhi Commission for Safai Karamcharis, (DCSK) u/s 32 (1) of the MS Act 2013 vide dated 03.02.2014.
2. Notification issued for constitution of State Monitoring Committee, (SMC) u/s 26 (1) of the MS Act 2013 vide dated 22.12.2017 by the UD Department, GNCTD.
3. Notification issued for constitution of District Level Survey Committee, (DLSC) u/s 11(1) of MS Act 2013 & clause (c) of Rule 2 and sub rule (2) of 11 of MS Rule 2013 vide dated 22.11.2017.
4. Order issued on 03.02.2014 u/s-7 on of MS Act 2013 that "No person local authority or any agency shall engage or employ, either directly or indirectly any person for hazardous cleaning of a sewer or a septic tank in the NCT of Delhi."

485 //True copy//

5. Order issued on Rehabilitation Programme u/s-7 of MS Act 2013 and accordingly, Cabinet Decision No. 2701, dated 27.06.2019 issued in this regard.

6. Monitoring Power conferred to the Commissioner of MCD, Secretary, NDMC and Deputy Commissioner (Revenue of 11 Districts) in r/o proper implementation of MS Act 2013 through the Order issued on 03.03.2014.

7. Sanitary Superintendents of MCD and Sanitary Inspectors of NDMC are appointed as "Inspectors" u/s-20 (1) of MS Act 2013 vide notification dated 03.03.2014.

8. Additional District Magistrates are appointed as First Class Judicial Magistrate u/s 21 (1) of MS Act 2013 vide notification 21.04.2014.

Further, communication have been made to the implementing Agencies/Department namely Revenue Department and (All the District Magistrate), MCD, DCSK, DCB, DJB, NDMC, DUSIB, Deptt. of UD, DDA, DSFDC, NCSC and NCST for compliance of other Directions issued by the Hon'ble Supreme Court in the matter of Dr. Balram Singh Vs Union of India and others, WPC no. 324 of 2020 vide dated 20.10.2023.

In view of above, it is requested to kindly apprise the Hon'ble court accordingly.

Encl: As above.

Deputy Director (MS)
DSCST

F.NO. 28(55)/2023/DSCST/P&G./Pt.file-II /12392-96

DATE: 29/01/2024

Copy for information to:

1. Economic Advisor, Social Justice and Empowerment Vigyan Bhawan New Delhi 110011.
2. The Secretary, National Commission for SafaiKaramcharis, (NCSK), GOI Ministry of Social Justice & Empowerment, 'B'-Wing, 4th Floor, Lok Nayak Bhawan, Khan Market, New Delhi-110003.
3. PP to Secretary, Social Justice and Empowerment Shastri Bhawan New Delhi 110001.
4. Office of Chief Secretary, Government of NCT of Delhi, 3rd Level, Delhi Secretariat, I.P. Estate, New Delhi-110002.

486 // True copy //

Deputy Director (MS)
DSCST

GOVERNMENT OF NCT OF DELHI
DEPARTMENT FOR THE WELFARE OF SC/ST/OBC
B-BLOCK, 2ND FLOOR VIKAS BHAWAN, I.P. ESTATE, NEW DELHI

No.F. 28(47)/2018-19/ DSCST /Pg.1 / 10815-33

Date: 21/8/19

1. The Pr. Secretary, Public Works Department, 5th Level, B-Wing, Delhi Secretariat
2. The Pr. Secretary, Urban Development Department, 9th Level, C-Wing, & 10 Level Delhi Secretariat.
3. The Chairman, New Delhi Municipal Council, Palika Kendra, Parliament Street, New Delhi
4. The Commissioner, North Delhi Municipal Corporation, 15th Floor, Civic Centre, New Delhi
5. The Commissioner, South Delhi Municipal Corporation, 15th Floor, Civic Centre, New Delhi
6. The Commissioner, East Delhi Municipal Corporation, Udyog Sadan, Patparganj Industrial Estate, Delhi.
7. The Divisional Railway Manager, Delhi Division, Northern Railways, State Entry Road, New Delhi-110055.
8. The CEO, Delhi Jal Board, Varunalaya, Jhandewalan, New Delhi
9. The CEO, Delhi Cantonment Board, Delhi Cantt., New Delhi
10. The Chief Engineer, Irrigation & Flood Control, L.M. Bund Office Complex, Shastri Nagar, Delhi-110031.
11. The CEO, Delhi Urban Shelter Improvement Board, Vikas Kutir, FFO, New Delhi
12. The CMD, DSIIDC, N-36, Bombay Life Building, Connaught Circus, New Delhi-110002
13. Divisional Commissioner, Revenue Department, 5 Shyam Nath Marg, Delhi-110051
14. The DCP (HQ), MSO Building, I.P.Estate, New Delhi-110002.
15. The Chairman, DCSK, GNCTD, 5477/72, Kalyan Bhawan, Kikarwala Chowk, Regarpura, Karol Bagh, New Delhi-110005.
16. MD, DSFDC, Ambedkar Bhawan, Institutional Area, Sector-16, Rohini, Delhi-89

Sub: Rehabilitation Programme to persons identified as Manual Scavengers in Govt. of NCT of Delhi under the provisions of The "Prohibition of Employment as Manual Scavengers and their Rehabilitation Act, 2013" (MS Act, 2013).

Sir,
As you are aware that the Council of Ministers, Govt. of NCT of Delhi vide Cabinet Decision No. 2701 dated 27.06.19 has considered and approved the Cabinet Note regarding Rehabilitation Programme to persons identified as Manual Scavengers in Govt. of NCT of Delhi under the provisions of The "Prohibition of Employment as Manual Scavengers and their Rehabilitation Act, 2013" (MS Act, 2013). The order w.r.t. this has already been circulated and uploaded on CDMS. However, I am directed to forward copy of order dated 11.07.19 for your kind perusal and further necessary action in the event of unfortunate incident occurred on account of above as this department has no direct bearing over the implementation and execution of rehabilitation programme.

Yours faithfully

Samuel

(MAHENDRA PAL)
DEPUTY DIRECTOR

Date: 21/8/19

Encl: As above

No.F. 28(47)/2018-19/ DSCST /Pg.1 / 10815-33

1. S.O. to CS, GNCTD, Delhi Secretariat, New Delhi-110002.
2. PS to Pr. Secretary, DSCST
3. PS to Special Secretary, DSCST

True copy!!

Samuel

DEPUTY DIRECTOR

12

Government, of NCT of Delhi
Department for the Welfare of SC/ST/OBC/Minorities
B-Block, 2nd Floor, Vikas Bhawan, I.P Estate, New Delhi
Website:scstwelfare.delhigovt.nic.in Tele Fax No.23379514

No.F.28(47)/2018-19/DSCST/PIB./

8885-96

Dated: 11/7/19

ORDER

It is hereby conveyed that the Council of Ministers, Govt of NCT of Delhi vide Cabinet Decision No.2701 dated 27/06/2019 has considered and approved the following proposal contained in para 4.1 to 4.6 in respect of Rehabilitation programme to persons identified as Manual Scavengers in Govt. of NCT of Delhi under the provisions of The "Prohibition of Employment as Manual Scavengers and their Rehabilitation Act 2013"(MS Act, 2013).

4.1 Issuance of identity card to manual scavengers(Sec 13(1)(a)(i)): Once the survey for identification of manual scavengers is completed as per provisions of the Act & Rules, the District Magistrate of the revenue district concerned shall further take necessary steps to issue identity cards to the identified manual scavenger containing details of all members of his family dependent on him.

4.2 Cash Assistance, scholarship, training in a livelihood skill including monthly stipend, subsidy and concessional loan for taking alternative occupation (Sec-13(1)(a)(ii),(b),(d)&(e)): Rehabilitation in the form of cash assistance of Rs. 40,000/-, skill development training, loans are already being provided by GOI through its 100% Centrally sponsored scheme of SRMS. And, Scholarship to the children of manual scavengers is being provided through another GOI 100% Centrally sponsored scheme Pre-Matric Scholarship to the children of those engaged in occupation involving cleaning and prone to health hazards.

The Delhi SC/ST/OBC/Minorities/Handicapped Finance Development Corporation (DSCFDC) being the State Channelizing Agency for various National Apex Finance Corporations is already implementing vocational training programmes, loan schemes etc for persons belonging to SC/ST/OBC/Minorities & handicapped from the funds being provided by various Apex Finance Corporations. Since manual scavengers mostly belong to the category of SC and as per guidelines of the scheme, DSCFDC may be entrusted with the work of implementing the centrally sponsored scheme of SRMS being implemented by National Safai Karamchari Financial Development Corporation (copy of guidelines enclosed).

The Centrally sponsored scheme of "Pre-Matric Scholarship to the children of those engaged in occupation involving cleaning and prone to health hazards" could be implemented by DSCST since it is already implementing various CSS schemes of Pre-Matric being funded by GOI.

The District Level Vigilance Committee constituted in each district, under the chairmanship of District Magistrate, is already mandated under Section 25 of the Act to oversee effective implementation of economic and social rehabilitation of manual scavengers. Also as per the guidelines of the SRMS Scheme, the District Level Vigilance Committee has to monitor the implementation of the scheme. Accordingly, the District Level Vigilance Committee may be entrusted to co-ordinate with

488
//True copy//

3/1
DSCFDC for effective implementation of SRMS scheme in respect of manual scavengers identified in their districts.

Further, Section 32 of the MS Act, 2013 also stipulates that State Commission for Safai Karamchari shall perform, *mutatis mutandis*, the function being performed by NCSK i.e to monitor the implementation of the Act, to enquire into complaints of contraventions of the provisions of the Act etc. Notification vide letter dt: 03/02/2014 has already been issued vide which Delhi Commission for Safai Karamchari has been designated to perform, *mutatis mutandis*, the functions specified in Section 31(1) of the Act. As such, The Commission for Safai Karamchari, GNCTD shall oversee the work of District Level Vigilance Committees and DSCFDC to ensure that the identified manual scavengers are able to reap the benefits of rehabilitation schemes being implemented by GOI.

4.3 Allotment of residential plot or readily-built house (Sec-13(1)(C)): Land do not come under the purview of Govt of NCT of Delhi, being a Union Territory. All eligible cases shall be scrutinized by the District Level Vigilance Committees as per the provisions of MS Act and Rules and subsequently forward all the eligible cases to the Commission for Safai Karamchari, GNCTD. The Commission after examination shall forward the eligible cases with its recommendation of Dept. for Welfare of SC/ST/OBC for onward transmission to Ministry of Social Justice & Empowerment, GOI for further action.

4.4 Providing of legal and programmatic assistance (Sec-13(1)(f)): Delhi State Legal Services Authority has been constituted by an act of Parliament to provide free and competent legal services to the weaker section of the society. Provision of the Delhi Legal Services Authority Regulation, 2002 stipulates providing of free legal aid to various categories of persons including SC or ST. If required, the District Level Vigilance Committees shall recommend the cases of identified manual scavengers, requiring legal aid, to DLSA for availing free legal aid.

4.5 The proposal was initially examined by Planning/Finance/Law Department and as per advice of Planning Department guidelines to be followed by DSCFDC, District Level Vigilance Committee and DCSK in implementing the rehabilitation programme have been prepared.

4.6 Financial implication: Expenditure for cash assistance, skill development training, loans shall be covered under the CSS scheme of SRMS. For implementing the CSS scheme of Pre-metric scholarship, budgetary provisions have to be made to meet the committed liability as per the scheme and the amount of committed liability can be ascertained only after completion of the process of identification of manual scavengers.

Encl: as above

(Dr. Philip Thanglienmang)
Special Secretary

No. F. 28(47)/2018-19/DSCST/Plg/1

Dated: 11/7/19

- 8885-96
1. Pr. Secretary to Lt. Governor, Delhi.
 2. Addl. Secretary to the Chief Minister, Delhi.
 3. Secretary to Dy. Chief Minister, Govt. of NCT of Delhi.
- 489

398/c

121/c

4. Secretary to Minister, Labour, Govt. of NCT of Delhi.
5. Secretary to Minister, Health, Govt. of NCT of Delhi.
6. Secretary to Minister, Food and Supply, Govt. of NCT of Delhi.
7. Secretary to Minister, Social Welfare, Govt. of NCT of Delhi.
8. Secretary to Minister, Transport, Govt. of NCT of Delhi.
9. Pr. Secretary (PWD), Govt. of NCT of Delhi.
10. OSD to Chief Secretary, Govt. of NCT of Delhi.
11. Assistant Programmer, DSCST with the request to upload the ATR on CDMS.



Special Secretary

//True copy//

490

(TO BE PUBLISHED IN PART-IV OF DELHI GAZETTE EXTRA-ORDINARY)

NATIONAL CAPITAL TERRITORY OF DELHI
DEPARTMENT FOR THE WELFARE OF SC/ST/OBC/MINORITIES,
B-BLOCK, 2ND FLOOR, VIKAS BHAWAN, I P ESTATE,
NEW DELHI-110002

No. F.7(7)/2013-14/DSCST/SCP/Vol. II/20439

Dated: 3/2/2017

NOTIFICATION

No. F.7(7)/2013-14/DSCST/SCP/Vol. II/20439-In exercise of the powers conferred by sub-section (1) of section 32 of the Prohibition of Employment as Manual Scavengers and their Rehabilitation Act, 2013 (25 of 2013), the Lieutenant Governor of the National Capital Territory of Delhi hereby designates the Delhi Commission for Safai Karamcharis to perform, within the National Capital Territory of Delhi, mutatis, mutandis, the functions specified in sub-section (1) of section 31 of the aforesaid Act.

By order in the name
of the Lieutenant Governor of the
National Capital Territory of Delhi,

//True copy//
✓

(D. S. PANDIT)
SECRETARY (SC/ST/OBC/MIN.)

491

DEPARTMENT OF URBAN DEVELOPMENT
NOTIFICATION

Delhi, the 22nd December, 2017

F. No. 13(56)/CC/UD/MB/2016/5693.—In exercise of the powers conferred by Section 26 (1) read with clause (r) of sub-section (1) of section 2 of the Prohibition of Employment as Manual Scavengers and their Rehabilitation Act, 2013 (25 of 2013), the Lt. Governor of the National Capital Territory of Delhi, hereby constitutes State Monitoring Committee as under:—

1. The Chief Minister, Government of National Capital Territory of Delhi. : Chairperson
2. The Minister –in- Charge of the Schedule Caste Welfare,
Government of National Capital Territory of Delhi : Member
3. Chairperson, Delhi Commission for Safai Karamcharis, : Member
4. Director, National Commission for Scheduled Caste : Member
5. i) Sh. Vishesh Ravi, M LA
ii) Sh. Manoj Kumar, M LA
iii) Ch. Fateh Singh, M LA] : Member
6. Commissioner of Police, Delhi : Member
7. Pr. Secretary, Home, Government of National Capital Territory of Delhi : Member
8. Secretary, Social Welfare, Government of National Capital Territory of Delhi : Member

True copy

75/c

- 9 Secretary, Urban Development Department,
Government of National Capital Territory of Delhi : Member
- 10 Commissioner, North Delhi Municipal Corporation : Member
- 11 Commissioner, South Delhi Municipal Corporation : Member
- 12 Commissioner, East Delhi Municipal Corporation : Member
- 13 Chairperson, New Delhi Municipal Council : Member
- 14 Chief Executive Officer, Delhi Cantonment Board : Member
- 15 Sr. DMO/H&FW/Divisional Hospital, North Railway, Delhi : Member
- 16 (i) Smt. Asha Balguhar : Member
E-13, Gali No. 1, Pratap Nagar, Delhi-110007.
- (ii) Smt. Anita Ujjainwal : Member
16/383, Trilokpuri, Delhi-91.
- (iii) Sh. Subhash Valmiki : Member
B-2/242, Sector-20, Rohini, New Delhi-110085.
- (iv) Sh. Rahul Birla : Member
H. No. 10795/5, 100 Quarter, Balmiki Colony,
Karol Bagh, New Delhi-110005.
- 17 Sh. P Sreedhar, GM, Oriental Bank of Commerce : Member
GM Convenor, SLBC, Delhi, Oriental Bank of Commerce,
Harsh Bhawau, E-Block, Connaught Place, New Delhi-110002
- 18 Secretary, Department for the Welfare of SC/ST/OBC/Minority, : Member
Government of National Capital Territory of Delhi. Secretary
- 19 The Divisional Commissioner, Chief Executive Officer, Delhi Jal Board and Chief Executive Officer, Delhi Urban Shelter Improvement Board will be co-opted in the Committee as nominees of the Chairperson as they have significant role to play in the implementation of Act.

493
True copy

(TO BE PUBLISHED IN DELHI GAZETTE-PART-IV-ORDINARY)

GOVERNMENT OF NATIONAL CAPITAL TERRITORY OF DELHI
DEPARTMENT FOR THE WELFARE OF SC/ST/OBC

Dated:

NOTIFICATION

F. No.28(15)/2017-18/DSCST/SCPI 11810-841 In exercise of the powers conferred by sub-

22/11/17

section (1) of section (11) of the Prohibition of Employment as Manual Scavengers and their Rehabilitation Act, 2013 read with clause (c) of rule 2 and sub-rule (2) of 11 of Prohibition of Employment as Manual Scavengers and their Rehabilitation Rules, 2013, the Hon'ble Lt. Governor of National Capital Territory of Delhi is pleased to constitute the District Level Survey Committee for each District of National Capital Territory of Delhi, consisting of the following members, namely :-

S.No.	Composition	Designation
1.	District Magistrate	Chairman
2.	Deputy Director/Astt. Director/Section Officer of the Department for the Welfare of Schedule Caste*	Member Secretary
3.	District Statistical Officer/Official	Member
4.	a) Executive Engineer Delhi Jal Board** b) Executive Engineer Municipal Corporation of Delhi**	Member
5.	Officer of Railways to be nominated by Divisional Railway Manager, Northern Railways.	Member(s)
6.	Upto two representatives of Non Govt. Organizations working for Welfare of Manual Scavengers and Safai Karamcharis to be nominated by District Magistrate concerned.	Member(s)
7.	Upto two community representatives of whom one should be a woman to be nominated by District Magistrate concerned.	Member(s)

* Since Department for the Welfare of SC/ST/OBC in centralized office, so the, Gazetted Officers of the department may be nominated by Secretary, Department for the Welfare of SC/ST/OBC in each district.
** Executive Engineers of Delhi Jal Board, North Delhi Municipal Corporation, South Delhi Municipal Corporation, East Delhi Municipal Corporation, New Delhi Municipal Council, Delhi Cantonment Board may be nominated as per their area jurisdictions.

//True copy//

By order and in the name of the
Lt. Governor of National Capital
Territory of Delhi,

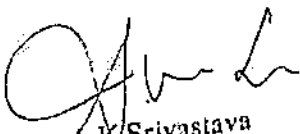
A.K. Srivastava
Dy. Director (DSCST)

494

Contd.....2/

(TO BE PUBLISHED IN PART-IV OF DELHI GAZETTE EXTRA-ORDINARY)

NATIONAL CAPITAL TERRITORY OF DELHI
DEPARTMENT FOR THE WELFARE OF SC/ST/OBC/MINORITIES,
B-BLOCK, 2ND FLOOR, VIKAS BHAWAN, -I P ESTATE,
NEW DELHI-110002.

No. F.7(7)/2013-14/DSCST/SCP/Vol-III/21235 Dated: the 23/3/2014

ORDER

No. F.7(7)/2013-14/DSCST/SCP/Vol-III/21235 .-In exercise of the powers conferred by section 18 of the "Prohibition of Employment as Manual Scavengers and their Rehabilitation Act, 2013" (25 of 2013), the Lieutenant Governor of the National Capital Territory of Delhi hereby authorises the Commissioners of all the three Corporations i.e. North Delhi Municipal Corporation, South Delhi Municipal Corporation, East Delhi Municipal Corporation and Secretary of New Delhi Municipal Council and Deputy Commissioners (Revenue) of all the eleven Revenue Districts to ensure that the provisions of this Act are properly carried out;

Further, the Commissioners of all the three Corporations i.e. North Delhi Municipal Corporation, South Delhi Municipal Corporation, East Delhi Municipal Corporation and Secretary of New Delhi Municipal Council and Deputy Commissioners (Revenue) of all the eleven Revenue Districts may specify the subordinate officers, who shall exercise all or any of the powers, and performs all or any of the duties, so conferred or imposed, and the local limits within which such powers or duties shall be carried out by the officer or officers so specified.

By order in the name
of the Lieutenant Governor of the
National Capital Territory of Delhi

//True copy//

(D. S. PANDIT)
SECRETARY (SC/ST/OBC/MIN)

(TO BE PUBLISHED IN PART-IV OF DELHI GAZETTE EXTRA-ORDINARY)

NATIONAL CAPITAL TERRITORY OF DELHI
DEPARTMENT FOR THE WELFARE OF SC/ST/OBC/MINORITIES,
B-BLOCK, 2ND FLOOR, VIKAS BHAWAN, I P ESTATE,
NEW DELHI-110002

No. F.7(7)/2013-14/DSCST/SCP/Vol. II/20438

Dated: 3/2/2014

O R D E R

No. F.7(7)/2013-14/DSCST/SCP/Vol. II/20438.- In exercise of powers conferred by section 7 of the Prohibition of Employment as Manual Scavengers and their Rehabilitation Act, 2013 (25 of 2013) and in supersession of order No.F.7(4)/2012-13/DSCST/SCP/909 dated the 12th April, 2013 published in Delhi Gazette Part-IV -Extra ordinary, the Lieutenant Governor of the National Capital Territory of Delhi hereby declares with immediate effect that no person, local authority or any agency shall engage or employ, either directly or indirectly, any person for hazardous cleaning of a sewer or a septic tank in the National Capital Territory of Delhi.

By order in the name
of the Lieutenant Governor of the
National Capital Territory of Delhi,

//True copy//



(D. S. PANDIT)
SECRETARY (SC/ST/OBC/MIN.)

15
(TO BE PUBLISHED IN PART IV OF DELHI GAZETTE EXTRA ORDINARY)

NATIONAL CAPITAL TERRITORY OF DELHI
DEPARTMENT FOR THE WELFARE OF SC/ST/OBC/MINORITIES,
B-BLOCK, 2ND FLOOR, VIKAS BHAWAN, I P ESTATE,
NEW DELHI-110002

No. F.7(7)/2013-14/DSCST/SCP/Vol-III/21236

Dated: the 03/3/2014

ORDER

No. F.7(7)/2013-14/DSCST/SCP/Vol-III/21236 .-In exercise of the powers conferred by sub section(1) of section 20 of the "Prohibition of Employment as Manual Scavengers and their Rehabilitation Act, 2013" (25 of 2013), the Lieutenant Governor of the National Capital Territory of Delhi hereby appoints all the Sanitary Superintendents of each Corporation i.e. North Delhi Municipal Corporation, South Delhi Municipal Corporation, East Delhi Municipal Corporation and all the Sanitary Inspectors of New Delhi Municipal Council as "Inspectors" to exercise all or any of the powers, and perform all or any of the duties, so conferred or imposed all duties on them within their local limits for the purpose of the said Act.

By order in the name
of the Lieutenant Governor of the
National Capital Territory of Delhi,

//True copy//

(D. S. PANDIT)

SECRETARY (SC/ST/OBC/MIN.)

497

20/c
TO BE PUBLISHED IN PART-IV OF DELHI GAZETTE EXTRA-ORDINARY)

**NATIONAL CAPITAL TERRITORY OF DELHI
DEPARTMENT FOR THE WELFARE OF SC/ST/OBC/MINORITIES,
B-BLOCK, 2ND FLOOR, VIKAS BHAWAN, I P ESTATE,
NEW DELHI -110002.**

....
No.F.7(7)/2013-14/DSCST/SCP/Vol.VI/

333

Ans
21/04/2014
Dated: 21/4/14

NOTIFICATION

No. F.7(7)/2013-14/DSCST/SCP/Vol.VI/ 333 - In exercise of the powers conferred by sub-section (1) of the section 21 of the Prohibition of Employment as Manual Scavengers and their Rehabilitation Act, 2013 (25 of 2013), the Lieutenant Governor of the National Capital Territory of Delhi hereby pleased to confer on all the eleven Additional District Magistrate, who have been conferred the powers of the Executive Magistrate in the National Capital Territory of Delhi, the powers of the Judicial Magistrate of the first class for trial of offences under the said Act in their respective jurisdiction for the purpose of the Code of Criminal Procedure, 1973 to be a Judicial Magistrate of the first class.

By order in the name
of the Lieutenant Governor of the
National Capital Territory of Delhi

K.P. Rangari

(K.P. RANGARI)
DY. DIRECTOR(SC/ST/OBC/MIN.)

//True copy//
S

498

Annexure-IV-C

पत्रांक-13/न०वि०स्व०नि०/न्या०-21/2024-386

न०वि०एवंआ०वि०

Government of Bihar
Urban Development and Housing Department

From,

Joint Secretary,
Urban Development and Housing Department,
Government of Bihar, Patna

To,

Deputy Secretary
Ministry of Social Justice and Empowerment,
Government of India, New Delhi

Date:-19-01-24

Subject: Compliance with the order in Writ Petition (Civil) No(s). 324 of 2020 issued by The Hon'ble Supreme Court of india Dated 20.10.2023 for Manual Scavenging and Hazardous Cleaning.

Reference: Letter No. U-12021/1/2023-PLAN, Dated 14.11.2023 of the Ministry of Social Justice and Empowerment, Government of india, New Delhi.

Sir,

With reference to the subject above, to comply with the directions issued by the Hon'ble Supreme Court of India, in Writ Petition (Civil) No(s). 324 of 2020, Dated 20.10.2023 for Manual Scavenging and Hazardous Cleaning, a compliance report has been prepared by the state and attached herewith for your kind perusal. You are requested to include the status report of State of Bihar in the court filing.

Enclosure: ibid

Yours Sincerely,

19/1/24

Joint Secretary,
Urban Development & Housing Department
Government of Bihar

//True copy.

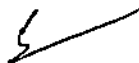

499

COMPLIANCE REPORT OF THE ORDER PASSED

UNDER

WRIT PETITION (CIVIL) NO(s). 324 OF 2020

IN THE HON'BLE SUPREME COURT OF INDIA

DR. BALRAM SINGH

VERSUS

UNION OF INDIA & OTHERS

ON

MANUAL SCAVENGING AND HAZARDOUS CLEANING

BY

URBAN DEVELOPMENT AND HOUSING DEPARTMENT

GOVT OF BIHAR

¹
//True copy//500
Σ

**Parawise Compliance Report of Order Dated 20.10.2023 in Writ
Petition (Civil) No(s). 324 of 2020 Passed by The Hon'ble
Supreme Court of India for Manual Scavenging and Hazardous
Cleaning.**

96 (2) Direction: *All States and Union Territories are likewise, directed to ensure that all departments, agencies, corporations and other agencies (by whatever name called) ensure that guidelines and directions framed by the Union are embodied in their own guidelines and directions; the states are specifically directed to ensure that such directions are applicable to all municipalities, and local bodies functioning within their territories.*

Compliance: 1. The state has adopted the Standard Operating Procedure (SOP) for "Cleaning of Sewers and Septic Tanks", developed by the Central Public Health and Environmental Engineering Organization (CPHEEO), Ministry of Housing and Urban Affairs, Government of India. The same has been circulated among the Urban Local Bodies vide letter no—2365, dated 01.06.2023 to adopt and implement locally. A copy of the aforementioned letter is attached in **Annexure I**.

//True copy"

501

✓

2. The state shall further adopt the upcoming guidelines/ SOPs released by the Ministry of Housing and Urban Affairs, Government of India in this regard.

3. For the cleaning of septic tanks in the state total of 650 cesspool tankers of Government as well as Private operators are available. District-wise availability of cesspool tankers is attached in Annexure II. In addition, 128 cesspool tankers have been approved by the Ministry of Housing and Urban Affairs, Government of India under Swachh Bharat Mission Urban 2.0.

96 (3) Direction: *The Union, State and Union Territories are directed to ensure that full rehabilitation (including employment to the next of kin, education to the wards, and skill training) measures are taken in respect of sewage workers, and those who die.*

Compliance: To ensure employment to the next of kin, education to the wards, and skill training for the dependents of the sewage workers and those who die, the process of approval from the state cabinet has been initiated after the approval of the Minister, Urban Development and Housing Department, Government of Bihar. The same shall be adopted by the state after the approval.

//True copy// 502
3

96 (4) Direction: The court hereby directs the Union and the States to ensure that the compensation for sewer deaths is increased (given that the previous amount fixed, i.e., 10 lakhs) was made applicable ₹ from 1993. The current equivalent of that amount is Rs. 30 lakhs. This shall be the amount to be paid, by the concerned agency, i.e., the Union, the Union Territory or the State as the case may be. In other words, compensation for sewer deaths shall be ₹ 30 lakhs. In the event, dependents of any victim have not been paid such amount, the above amount shall be payable to them. Furthermore, this shall be the amount to be hereafter paid, as compensation.

96 (5) Direction: Likewise, in the case of sewer victims suffering disabilities, depending upon the severity of disabilities, compensation shall be disbursed. However, the minimum compensation shall not be less than 10 lakhs. ₹ If the disability is permanent, and renders the victim economically helpless, the compensation shall not be less than ₹ 20 lakhs.

Compliance: To ensure the minimum compensation of 10 lakhs to the sewer victims suffering from disabilities, 20 lakhs for permanent disabilities, and 30 lakhs for sewer death, the process of approval from the state cabinet has been initiated after the approval of the Minister,

//True copy//

₹

503

Urban Development and Housing Department, Government of Bihar.
The same shall be adopted by the state after the approval.

96 (6) Direction: *The appropriate government (i.e., the Union, State or Union Territories) shall devise a suitable mechanism to ensure accountability, especially wherever sewer deaths occur in the course of contractual or "outsourced" work. This accountability shall be in the form of cancellation of contract, forthwith, and imposition of monetary liability, aimed at deterring the practice.*

Compliance: The appropriate clause has been incorporated in the model RFP/ Contract of the department which is under review. The same shall be finalized soon and adopted at the earliest.

96 (10) Direction: *The Union, State and Union Territories are hereby required to set up scholarships to ensure that the dependents of sewer victims, (who have died or might have suffered disabilities) are given meaningful education.*

Compliance: The scholarships for the dependents of sewer victims, (who have died or might have suffered disabilities) are covered in the various

//True copy 504
✓

scholarship schemes of the Education Department, Government of Bihar. A copy of the scholarship schemes is attached in Annexure III.

96 (12) Direction: *The Union, State and Union Territories are hereby directed to ensure coordination with all the commissions (NCSK, NCSC, NCST) for setting up of state level, district level committees and commissions, in a time bound manner. Furthermore, constant monitoring of the existence of vacancies and their filling up shall take place.*

Compliance: Various committees to coordinate with all the commissions (NCSK, NCSC, NCST) have been formed in the state. The details of the constitution of committees as per letter no. 3109 dated 29.11.2023 (copy attached as annexure IV) of Bihar Mahadalit Vikas Mission are as follows:

1. **Bihar Mahadalit Vikas Mission, Patna** is working as a State Commission for Safai Karamchari vide notification no. 3019, dated - 05.11.2019.
2. **State Monitoring Committee** has been constituted vide notification no.- 1950, dated 14.10.2014.
3. **District Vigilance Committee** has been constituted in 38 districts.
4. **Subdivision Vigilance Committee** has been constituted in 85 sub-divisions out of 101 sub-divisions.

//True copy

505

For the compliance of letter no. U-12021/1/2023-PLAN, dated 14.11.2023 of the Ministry of Social Justice and Empowerment, Government of India, the state has nominated the Principal Secretary, Urban Development and Housing Department (UD&HD), Government of Bihar as Nodal Officer for the Writ Petition (Civil) No(s). 324 of 2020 under the Hon'ble Supreme Court of India for Manual Scavenging and Hazardous Cleaning vide office order no. 30, vide memo no. 387 dated 19.01.2024. The details are as follows:

Name	Designation	Contact Number	Email ID
Sri Santosh Kumar Mall	Principal Secretary, UD&HD, GoB	0612-2215550	urbansec-bih@nic.in

//True copy//



506

7

11/11/11

11/11/11





GOVERNMENT OF KERALA

Local Self Government (WM) Department

No.WM2/96/2023-LSGD

29-01-2024, Thiruvananthapuram

From

The Additional Chief Secretary to Government

To

Sri.S.K Srivastwa, Deputy Secretary
Department of Social Justice & Empowerment, MoSJ&E,
B-2 Ground Floor, Pt.Deendayal Antyodaya Bhawan, CGO
Complex, New Delhi-3

Sir,

Sub: WP(c) No.324/2020 filed by Dr. Balram Singh and another
before the Hon'ble Supreme Court of India- Judgment -
Compliance Report - reg:

Ref: 1.Your Letter No. U-12021/1/2023-PLA dated 14.11.2023
2.G.O.(Ms) No. 15/2024/LSGD dated 29.01.2024 issued by
Government of Kerala

In inviting your attention to the subject mentioned, I am pleased to
furnish hereby a detailed account of the actions taken by the State of
Kerala in compliance with the Judgment dated 20.10.2023 in WP(C)
No.324/2020 filed by Dr. Balram Singh and another before the Hon'ble
Supreme Court of India.

In the said judgment, the following directions were issued:

*96 (2) All States and Union Territories are likewise, directed to ensure
that all departments, agencies, corporations and other agencies (by
whatever name called) ensure that guidelines and directions framed by
the Union are embodied in their own guidelines and directions; the
states are specifically directed to ensure that such directions are*

507

//True copy//

[Signature]

applicable to all municipalities, and local bodies functioning within their territories.

In compliance with the above direction, all Local Bodies in the State of Kerala have been instructed to comply with the The Prohibition of Employment as Manual Scavengers and their Rehabilitation Act, 2013. and the Rules therein.

96 (3) The Union, State and Union Territories are directed to ensure that full rehabilitation (including employment to the next of kin, education to the wards, and skill training) measures are taken in respect of sewage workers, and those who die; and

96 (10) The Union, State and Union Territories are hereby required to set up scholarships to ensure that the dependents of sewer victims, (who have died, or might have suffered disabilities) are given meaningful education.

In furtherance of the above directions of the Hon'ble Supreme Court, the State Planning Board has been asked to investigate the feasibility of encouraging the Local Bodies to take up projects for full rehabilitation of sewage workers in their Annual Plans. These projects, to be implemented within the framework of the decentralized planning process, would encompass initiatives such as scholarships, skill training etc for dependents of those affected by sewer work-related hazards. Local bodies in the State have already been directed to mandatorily take up projects to equip sanitation workers involved in drainage cleaning and desludging with protective gear and to transition towards a "zero touch" system for these tasks.

96 (4) The court hereby directs the Union and the States to ensure that the compensation for sewer deaths is increased (given that the previous amount fixed, i.e., ₹ 10 lakhs was made applicable from 1993). The current equivalent of that amount is Rs. 30 lakhs. This shall be the amount to be paid, by the concerned agency, i.e., the Union, the Union Territory or the State as the case may be. In other words, compensation for sewer deaths shall be ₹ 30 lakhs. In the event, dependents of any victim have not been paid such amount, the above amount shall be payable to them. Furthermore, this shall be the amount to be hereafter paid, as compensation.

96 (5) Likewise, in the case of sewer victims suffering disabilities, depending upon the severity of disabilities, compensation shall be

disbursed. However, the minimum compensation shall not be less than ₹ 10 lakhs. If the disability is permanent, and renders the victim economically helpless, the compensation shall not be less than ₹ 20 lakhs.

To date, a total of thirteen identified families have received compensation of ten lakh rupees each for deaths attributed to sewer-related hazards. No dues are pending to be disbursed from the Government in this matter.

96 (6) The appropriate government (i.e., the Union, State or Union Territories) shall devise a suitable mechanism to ensure accountability, especially wherever sewer deaths occur in the course of contractual or "outsourced" work. This accountability shall be in the form of cancellation of contract, forthwith, and imposition of monetary liability, aimed at deterring the practice.

In strict adherence to the above direction, the State Government has issued G.O.(Ms)No.15/2024/LSGD dated 29.01.2024 (Copy Enclosed) stipulating that every Local Self Government Institution in the State, while entrusting the sewer works to any agency, shall specify in the contract that the contract shall be canceled and monetary liability imposed, if death of a person deputed for sewer work occurs in the course of contractual or outsourced work, due to the failure to ensure safety measures envisaged under the Advisory on Technical and Managerial Interventions for ensuring Safety during Sewer and Septic Tank Cleaning and the Standard Operating Procedure (SOP) for Cleaning of Sewers and Septic Tanks issued by Ministry of Housing and Urban Affairs, Government of India.

In light of the aforementioned actions, I request you to kindly accept the compliance report and also to file a status report on behalf of the State of Kerala positively before the Hon'ble Supreme Court of India.

Yours faithfully,

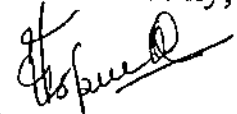

PREETHA K S

ADDITIONAL SECRETARY

For Additional Chief Secretary to Govt :

True copy



GOVERNMENT OF KERALA

Abstract

Local Self Government - WP(C) No.324/2022 filed by Dr. Balram Singh before Hon'ble Supreme Court of India - Judgment dated 20.10.2023- Directions in Para 96(6) - Complied - Orders Issued

LOCAL SELF GOVERNMENT (WM) DEPARTMENT

G.O.(Ms)No.15/2024/LSGD Dated, Thiruvananthapuram, 29-01-2024

Read 1 Judgment dated 20.10.2023 in WP(C) No.324/2022 filed by Dr. Balram Singh before Hon'ble Supreme Court of India

ORDER

The Hon'ble Supreme Court of India in WP(C) No. 324/2022 filed by Dr. Balram Singh has disposed of the Writ Petition with Judgment dated 20.10.2023. Para 96 (6) of the Judgment reads as follows:

"The appropriate government (i.e., the Union, State or Union Territories) shall devise a suitable mechanism to ensure accountability, especially wherever sewer deaths occur in the course of contractual or outsourced work. This accountability shall be in the form of cancellation of contract, forthwith, and imposition of monetary liability, aimed at deterring the practice".

Government, having examined the matter in detail, orders that every Local Self Government Institution in the State of Kerala, while entrusting the sewer works to any agency, shall specify in the contract that the contract shall be cancelled and monetary liability shall be imposed, if death of a person deputed for sewer work occurs in the course of contractual or outsourced work, due to the failure to ensure safety measures envisaged under the Advisory on Technical and Managerial Interventions for ensuring Safety during Sewer and Septic Tank Cleaning and the Standard Operating Procedure (SOP) for Cleaning of Sewers and Septic Tanks issued by Ministry of Housing and Urban Affairs, Government of India. The monetary liability shall be specified in the

514/True copy

agreement.

Existing agreements, predating this GO where there are more than three months left for completion of period of agreement shall also be revised accordingly.

(By order of the Governor)
SARADA MURALEEDHARAN I A S
ADDITIONAL CHIEF SECRETARY

To:

1. The Principal Director, Local Self Government Department.
2. The Advocate General , Ernakulam
3. Labour & Skills Department
- 4.Finance Department, Government of Kerala.
5. Secretaries of all Local Self Government Institutions (through Principal Director)
- 6.SF/OC

//True copy//



Forwarded /By order

Signed by

Viraj K

Date: 29-01-2024 18:48:27

Section Officer

भारत सरकार/GOVERNMENT OF INDIA
रेल मंत्रालय/MINISTRY OF RAILWAYS
रेलवे बोर्ड/RAILWAY BOARD

2023/E(LL)/SCA/5

New Delhi, dated 29.12.2023

OFFICE MEMORANDUM

Sub: Civil Writ Petition (PIL) No.324 of 2020 in the matter of Dr. Balram Singh vs Union of India & Others pending before Supreme Court of India - Regarding

The undersigned is directed to refer to Secretary, Ministry of Social Justice & Empowerment's DO letter No.U-12021/01/2023-Plan dated 17.11.2023, addressed to Chairman Railway Board & CEO. to take necessary action for timely compliance of the following observations of Hon'ble Supreme Court seeking an Action Taken Report in the matter:-

- (i) Full rehabilitation (including employment to the next of kin, education to the wards, and skill training) of sewage workers, and those who die [para 96(3)];
- (ii) Payment of compensation with increased amount i.e. Rupees 30 Lakhs for sewer deaths. In the event, dependent of any victim have not been paid such amount, the above amount shall be payable to them. hereafter as compensation [para 96(4)];
- (iii) Payment of compensation of Rs.20 Lakhs, in the case of sewer victims suffering disabilities, depending upon the severity of disabilities. Minimum compensation shall not be less than Rupees 10 Lakhs [para 96(5)];
- (iv) Set up scholarships to ensure that the dependents of sewer victims, (who have died, or might have suffered disabilities) are given meaningful education [para 96(10)].

2. Based on the information received from all Zonal Railways and Production Units, it is stated that, all the above 04 directives have been duly complied with over all the Zonal Railways & Production Units.

//True copy//

(M.K. Meena)

Joint Director Estt (LL)
Railway Board

Tel No: 011-23047136

Email: maheshkr.meena69@gov.in

Shri S.K. Srivastwa,
Deputy Secretary,
Department of Social Justice & Empowerment,
Ministry of Social Justice & Empowerment,
B-2, Ground Floor,
Pt. Deendayal Antyodaya Bhawan,
CGO Complex, New Delhi - 110003

Directorate General, Defence Estates
Cantonment Division

Sub: Civil Writ Petition (PIL) No. 324 of 2020 In the matter of Dr. Balram Singh VS Union of India and Other pending Before Supreme Court of India - regarding.

Reference D.O. letter No. U-12021/1/2023-PLAN dated 17.11.2023 of Shri Saurabh Garg, Secretary, Mo SJE, Govt. of India and Supreme Court Order dated 20.10.2023 in WP(C) No.324/2020 regarding Manual Scavengers.

2. It was requested vide DO letter under reference for compliance of Hon'ble Supreme Court order dated 20.10.2023 and to submit an Action taken report in matter.

3. It is intimated that suitable directions have already been issued to All Principal Directorates, Defence Estate on the subject matter wherein it is directed to all the Cantonment Boards to comply with directions of Hon'ble Supreme Court order dated 20.10.2023 in WP(C) No. 324/2020 with special attention to following points:-

- (i) Cantonment Boards to comply with MS Rules, 2013 to ensure that manual sewer cleaning is completely eradicated.
- (ii) Full rehabilitation (including employment to the next of kin, education to the wards, and skill training) measures are to taken in respect of sewage workers, and those who die.
- (iii) Payment of increased amount of compensation i.e., Rs. 30 lakhs for sewer deaths. In the event, dependents of any victim have not been paid such amount, the above amount shall be payable to them, hereafter as compensation.
- (iv) Payment of compensation of Rs. 20 lakhs, in the case of sewage victims suffering disabilities, depending upon the severity of disabilities. Minimum compensation shall not be less than Rs.10 lakhs.

4. Action taken report is submitted accordingly for info & further necessary action please.

(Arvind Kumar Dwivedi)
DDG(Cantts)

Shri S.B. Prasad
US/MoSJE

File No.70/VIP Ref.202/C/DE/2014 Vol-VIII

Dated: 01 Jan, 2024

Copy to :-
DD, D(Q&C)

True copy

मोनाली पी. धकाटे
संयुक्त सचिव
MONALI P. DHAKATE
Joint Secretary



सत्यमेव जयते

आजादी का
अमृत महोत्सव

भारत सरकार
सामाजिक न्याय और अधिकारिता मंत्रालय
सामाजिक न्याय और अधिकारिता विभाग
शास्त्री भवन, नई दिल्ली-110 115
GOVERNMENT OF INDIA
MINISTRY OF SOCIAL JUSTICE AND EMPOWERMENT
DEPARTMENT OF SOCIAL JUSTICE & EMPOWERMENT
Shastri Bhawan, New Delhi-110 115

No. PMD-17/1/2024-PM-DAKSH

New Delhi, the 09th January, 2024

To

Sh. Prabhat Kumar Singh,
Managing Director,
NSKFDC, NTSC, 3rd Floor,
E-Block, NSIC, Okhla industrial Estate- III,
New Delhi-110020

Sir,

The Department of Social Justice and empowerment is mandated to empower the socially, educationally and economically marginalized sections of the society including manual scavengers. The National Safai Karamcharis Finance and Development Corporation (NSKFDC) is Nodal Agency under the Department engaged for the welfare of Safai Karamcharis including manual scavengers. Further PM DAKSH is a Central Sector Scheme under implementation since 2020-21 with the objective to provide high quality skills to target groups including Safai Karamcharis to facilitate them adopt new processes and increase their incomes. During 2023-24, training targets have been given to NSKFDC under PM DAKSH for imparting training to Safai Karamcharis.

2. National Action Plan for Mechanized Sanitation Ecosystem (NAMASTE) is another Central Sector scheme, in which various facilities including providing them assistance for Health insurance, Occupation safety training, PPE kits and safety device are provided to Safai Karamcharis/Manual Scavengers.

3. In this context, it is mentioned that recently, the well being of Safai Karamcharis came for discussion in the Writ Petition (C) No.324/2020 of Dr. Balram Singh vs UOI, The Hon'ble Supreme Court vide order dated 20.10.2023 has passed extensive direction in this regard for compliance by States/UTs as well as Govt of India. The relevant direction available in para 96(3) of the order is reproduced as under:

"The Union, State and Union Territories are directed to ensure that full rehabilitation (including employment to the next of kin, education to the wards, and skill training) measures are taken in respect of sewage workers, and those who die;

4. It is accordingly requested that the Court Order in Writ Petition (C) No. 324/2020 may please be downloaded and directions of the Hon'ble Court may be implemented in letter and spirit. The various actions taken by the State and UTs Governments and NSKFDC in compliance with these directions may be reported to Plan Division of the Ministry under intimation to us.

True copy

Yours faithfully,
(Signature)
9/1/24
(MONALI P. DHAKATE)

514



सत्यमेव जयते

आजादी का
अमृत महोत्सव

मोनाली पी. धकाटे
संयुक्त सचिव
MONALI P. DHAKATE
Joint Secretary

भारत सरकार
सामाजिक न्याय और अधिकारिता मंत्रालय
सामाजिक न्याय और अधिकारिता विभाग
शास्त्री भवन, नई दिल्ली-110 115

GOVERNMENT OF INDIA
MINISTRY OF SOCIAL JUSTICE AND EMPOWERMENT
DEPARTMENT OF SOCIAL JUSTICE & EMPOWERMENT
Shastri Bhawan, New Delhi-110 115

D.O. No. PMD-17/1/2024-PM-DAKSH

New Delhi, the 09th January, 2024

Dear Sir/Madam

The Department of Social Justice and Empowerment is mandated to empower the socially, educationally and economically marginalized sections of the society including manual Scavengers. The National Safai Karamcharis Finance and Development Corporation (NSKFDC) is Nodal Agency under the Department engaged for the welfare of Safai Karamcharis including manual Scavengers. Further PM DAKSH is a Central Sector Scheme under implementation since 2020-21 with the objective to provide high quality skills to target groups including Safai Karamcharis to facilitate them adopt new processes and increase their incomes. During 2023-24, training targets have been given to NSKFDC under PM DAKSH for imparting training to Safai Karamcharis.

2. National Action Plan for Mechanized Sanitation Ecosystem (NAMASTE) is another Central Sector scheme, in which various facilities including providing them assistance for Health insurance, Occupation safety training, PPE kits and safety device are provided to Safai Karamcharis/Manual Scavengers.

3. In this context, it is mentioned that recently, the well being of Safai Karamcharis came for discussion in the Writ Petition (C) No.324/2020 of Dr. Balram Singh vs UoI. The Hon'ble Supreme Court vide order dated 20.10.2023 has passed extensive direction in this regard for compliance by States/UTs as well as Govt of India. The relevant direction available in para 96(3) of the order is reproduced as under:

"The Union, State and Union Territories are directed to ensure that full rehabilitation (including employment to the next of kin, education to the wards, and skill training) measures are taken in respect of sewage workers, and those who die;

4. It is accordingly requested that the Court Order in Writ Petition (C) No. 324/2020 may please be downloaded and directions of the Hon'ble Court may be implemented in letter and spirit. The various actions taken by the State and UTs Governments and NSKFDC in compliance with these directions may be reported to Plan Division of the Ministry under intimation to us.

IT/MS copy//

Yours sincerely,
Monali P. Dhakate
9/1/24
(MONALI P. DHAKATE)

1. Principal Secretaries/Secretaries
Social Welfare Department of all States and UTs
(As per list attached)

2. CMD, NSKFDC

515

Sr.No.	State/UTs	Name & Address	Email ID
1.	Andhra Pradesh	Ms. G. Jaya Lakshmi, Principal Secretary Social Weifare (Senior Citizen) Govt. of Andhra Pradesh Room No. 269, 3 rd Block, 1 st Floor, A.P. Secretariat, Velagapudi Amravati- 522503 E-mail: peshi.wcdsc@gmail.com	peshi.wcdsc@gmail.com
2.	Arunachal Pradesh	Shri Abu Tayeng, IAS, Secretary Deptt. Of Social Justice & Empowerment and Tribal Affairs (SJETA) Govt. of Arunachal Pradesh, Itanagar- 791111	sjeta-deptt@arn.gov.in
3.	Assam	Shri Mukesh Kumar Sahu, Principal Secretary, D/o Welfare of Plain tribes and Backward Classes Assam- Secretariat, D-Block, 1st Floor, Dispur JanataBhawan, Dispur Guwahati-781006 Email: mcsahu.ias@gmail.com	mcsahu.ias@gmail.com mukesh.sahu@gov.in +91-361-2237332
4.	Andaman & Nicobar Islauds	Mrs. Nandini Paliwal Commissioner cum Secretary Social Welfare/ Administration Department Directorate of Social Welfare, Guigar, Andaman & Nicobar Islands Pin Code- 744101 E-maii: adsocialwelfare@gmail.com	adsocialwelfare@gmail.com secretary.an102@gmail.com 03192-233227
5.	Bihar	Shri Prem Singh Meena, Secretary Social Welfare Department Schedule Caste & Schedule Tribe Welfare Deptt., Block No. 4, 2 nd floor, Behind SinehaiBhawan, Old Secretariat Campus, Bihar, Patna- 800015 Email: secysw-bih@nic.in , swbihar@gmail.com	secysw-bih@nic.in , swbihar@gmail.com
6.	Chhattisgarh	Shri D. D Singh, Secretary Department of ST & SC Development Govt. of Chhattisgarh, Mahanadi Bhawan, Raipur – 492001 Email: ctd.cg@nic.in , ddsinghias1961@gmail.com	ctd.cg@nic.in , ddsinghias1961@gmail.com
7.	Chandigarh	Shri Nitin Kumar Yadav, Secretary Department of Social Welfare & Women and Child Deptt., 3 rd floor, Towu Hall, Sector 17-C, Chaudigarh Administration, Chandigarh – 160017 Email: hs-chd@nic.in	hs-chd@nic.in

TRUE COPY
516

8.	Delhi	Shri Virender Kumar SC, ST & OBC and Minorities Welfare Deptt., Department of Social Welfare, Govt. of NCT of Delhi, GLNS Complex, New Delhi-110001 Email: scstsecretary@gmail.com	scstsecretary@gmail.com pssw@nic.in
9.	Daman & Diu	Dr. Bhanu Prabha, Secretary, Collector of Dadar & Nagar Haveli Social Welfare Department Collectorate, Siiwassa, Pincod- 396230 Email: sociawelfare-daman@yahoo.com	socialwelfare-daman@yahoo.com icpsswd@gmail.com
10.	Goa	Shri Subhash Chandra, Secretary Social Welfare Department Government of Goa, Secretariat, Porvorim, Panaji- 403521 Email: secy-wrd@goa.gov.in , dir-tw.goa@nic.in soci.goa@nic.in	secy-wrd@goa.gov.in , dir-tw.goa@uic.in soci.goa@nic.in
11.	Gujarat	Ms. Sunaina Tomar, Secretary Social Justice and Empowerment Deptt., Government of Gujarat, Sachivalya, Gandhinagar- 382010 Email: secswd@gujarat.gov.in	secswd@gujarat.gov.in
12.	Haryana	Shri Vijayendra Kumar, Principal Secretary, Social Justice Empowerment, Welfare of SC & BC Antyodaya Deptt. 2 nd floor, Haryana New Secretariat, Chandigarh Haryana-160101 Email: acssje@gmail.com	acssje@gmail.com
13.	Himachal Pradesh	Ms. M. Sudha Devi, Secretary Department of Social Justice and Empowerment Himachal Pradesh Secretariat 431, Armsdale Building Shimla-171002 Email: socialjesecy-hp@nic.in	socialjesecy-hp@nic.in
14.	Jammu & Kashmir	Ms. Sheetal Nauda, Secretary Social Welfare Department Govt. of Jammu & Kashmir, Civil Secretariat, Jammu- 180001 Email: socialwelfare.adm@gmail.com	socialwelfare.adm@gmail.com

TRUE COPY"
517

15.	Jharkhand	Shri Kamal Kishore Soau, Secretary Social Welfare Department, Govt. of Jharkhand, Saehivalya, Ranchi- 834004 Email: secretary.welfare@gmail.com	secretary.welfare@gmail.com
16.	Karnataka	Sri P Manivannan, Secretary Social Welfare Department Govt. of Karnataka Room No. 232-233, 2 nd floor, VikasSoudha, Bangalore- 560001 Email: comr.sw@gmail.com , prsocialwelfare@gmail.com	comr.sw@gmail.com , prsocialwelfare@gmail.com
17.	Kerala	DrSharmila Mary Joseph, Principal Secretary Social Justice, Govt. Kerala Secretariat, Thiruvananthapuram-695001 Email: chiefsecy@kerala.gov.in , crsecrylsgdruralcer@gmail.com	chiefsecy@kerala.gov.in , crsecrylsgdruralcer@gmail.com
18.	Ladakh	Ms. Padma Angmo, Secretary Social Welfare Office, Civil Secretariat, Leh, Ladakh- 194101 Email: secretarypaladakh@gmail.com	secretarypaladakh@gmail.com
19.	Lakshadweep	Shri Om Prakash Mishra, Secretary Social Welfare and Tribal Affairs Deptt., Old DP Building Ground Floor Secretariat Kavaratti, Lakshadweep Email: mishra.op@gov.in	mishra.op@gov.in
20.	Madhya Pradesh	Ms. Pallavi Jain Govil, Principal Secretary ST & SC Welfare Department Govt. of Madhya Pradesh, Room No. 210 VallabhBhawau, Bhopal- 462004 Email: psscwbho@mp.gov.in	psscwbho@mp.gov.in
21.	Maharashtra	ShriSumantBhange, Secretary Social Justice & Special Assistance Department Govt. of Maharashtra, MantralayaAnnexe, Mumbai- 400032 Email: comm.socwelfare@maharashtra.gov.in , sec.socjustice@maharashtra.gov.in ,	comm.socwelfare@maharashtra.gov.in sec.socjustice@maharashtra.gov.in ,
22.	Manipur	Dr. Rajesh Kumar, Chief Secretary Government of Manipur, South Block, Old Secretariat, Imphal – 795001 Email: cs-manipur@nic.in	cs-manipur@nic.in E- singhdhaneshwor34@gmail.com M- 9436027993

TRUE COPY
518

23.	Meghalaya	Shri E. Kharmalki, Secretary Social Welfare Department Govt. of Meghalaya, Secretariat Building Shillong – 793001 Email: ekharm@gmail.com	ekharm@gmail.com
24.	Mizoram	Dr. Renu Sharma, Chief Secretary Government of Mizoram, New Secretariat Complex, Aizawl – 796001 Email: cs_miz@rediffmail.com, csmizoram@gmail.com, cs-mizoram@nic.in	cs_miz@rediffmail.com, csmizoram@gmail.com, cs-mizoram@nic.in swtamizoram@gmail.com M-9436141306
25.	Nagaland	Ms. Martha Ritse Principal Secretary Government of Nagaland, The Directorate of Social Welfare, Near Raj Bhawan, Kohima Nagaland Pin Code: 797001 Email: socialwelfaredepartment_nagaland@yahoo.com Email: swd_nagaland@yahoo.co	socialwelfaredepartment_nagaland@yahoo.com swd_nagaland@yahoo.co.in langsym@gmail.com M-8974415834
26.	Odisha	Shri Saswata Mishra, Principal Secretary ST & SC Development, Minorities & Backward Classes Welfare Department Govt. of Odisha, Secretariat, Bhubaneswar - 751001 Email: stscdev@gmail.com	stscdev@gmail.com
27.	Puducherry	Shri R. Kesavan, Secretary Adi-Dravidar Welfare Department Kamaraj Salai, Tattanchavadi, Puducherry- 605009 Email: secywel.pon@nic.in	secywel.pon@nic.in M- 9443679067
28.	Punjab	Smt. Kavita Singh, Secretary Social Security & Development, Women & Child Department, Punjab Civil Secretariat Room No. 8 Floor No. 8, Chandigarh-160001 Tel. No. 0172-2746522, Fax No. 0172-2743854	psss@punjab.gov.in dsswed@rediffmail.com dsswed@punjab.gov.in
29.	Rajasthan	Shri Samti Sharma, Secretary Social Justice & Empowerment Department G-3/1, Ambedkar Bhawan, Rajmahal Residency Area, Jaipur-302005 Secretariat, Jaipur-302005 Email: sie@rajasthan.gov.in,	sje@rajasthan.gov.in, raj.sje@rajasthan.gov.in

TRUE COPY
519

		raj.sje@rajasthan.gov.in	
30.	Sikkim	Dr. A.B. Karki, Secretary Social Welfare Department, Govt. of Sikkim Samaj Kalyau Bhawan, Lumsey, 5 th miie, Secretary office, Sikkim, Todong-737102 Email: sikkim.socialwelfare@gmail.com	sikkim.socialwelfare@gmail.com
31.	Tamil Nadu	Shri T.S Jawahar, Secretary Adi-Dravidar and Tribal Welfare Department Govt. of Tamil Nadu State Secretariat, Chennai- 600009 Email: adisec@tn.gov.in	adisec@tn.gov.in
32.	Telangana	Sri Rahul Bojja, Secretary Scheduled Caste Development Department Govt. of Telangana, Teiangan Secretariat, Hyderabad- 500022 sec_scd@telangana.gov.in , secyscdts@gmail.com	sec_scd@telangana.gov.in , secyscdts@gmail.com
33.	Tripura	ShriAbhishek Singh, Secretary Social Welfare Department, Govt. of Tripura, New Secretariat, Agartala- 799006. Email: secretaryswse010422@gmail.com	secretaryswse010422@gmail.com
34.	Uttar Pradesh	Shri Sameer Verma, Secretary Social Weifare Department Govt. of Uttar Pradesh, State Secretariat, Lucknow- 226001 Shri Hariom, Principal Secretary, Social Welfare Department, 501/2 BapuBhawan, Uttar Pradesh Sachivalaya, Lucknow -226001 Email: pssw2020@gmail.com	Secretarysamajkalyan2022@gmail.com pssw2020@gmail.com
35.	Uttarakhand	Shri L. Fanai, Secretary Social Welfare Department Govt. of Uttarakhand, Secretariat, Dehradun – 248001 Email: lalrinlianafanai30@gmail.com directorsocialwelfare@gmail.com	lalrinlianafanai30@gmail.com directorsocialwelfare@gmail.com
36.	West Beugal	Smt. SanghamitraGhosh, Principal Secretary, Deptt. Women & Child Development and Social Welfare Govt. of West Bengal BikashBhavan, 10 th Fioor, Salt Lake, Kolkata- 700091	secy.wcdswF@gmail.com

//TRUE COPY// 520
S

		Email: secy.wcdsw@gmail.com	
--	--	-----------------------------------------------------------------------	--

//True copy//

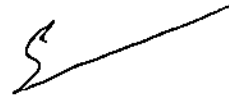

File No. U-12012/01/2023- PLAN
Government of India
Ministry of Social Justice and Empowerment
Department of Social Justice and Empowerment

307, Vigyan Bhawan Annexe,
New Delhi - 110011.
Dated: 22 December, 2023

To,

Ms. Santosh Snehi Mann,
Member Secretary,
National Legal Services Authority,
B-Block, Ground Floor, New Additionai Building Complex,
Supreme Court of India,
New Delhi- 110001.
Tel No. 011-23382778
Email- nalsa-dla@nic.in

Sub: Hon'ble Supreme Court order dated 20.10.2023 in WP (C) No 324/2020 filed by Dr. Balram Singh- reg.

Madam,

I am to refer to the subject mentioned above and to say that Dr. Bairam Singh filed the WP (C) No. 324/2020 v/s Uoi through Ministry of Environment and all the States and UTs before Hon'ble Supreme Court of India and prayed for directions for implementation of various ruies including "The Employment of Manuai Scavengers and Construction of Dry Latrines (Prohibition) Act, 1993" and "The Prohibition of Employment as Manual Scavengers and their Rehabilitation Act, 2013".

2. Hon'ble Court vide order dated 20.10.2023 (copy enclosed) has directed for compiance including following observations and listed the case for 01.02.2024:-

"Para 96 (11) The National Legal Services Authority (NALSA) shall also be part of the consultations, toward framing the aforesaid policies. It shall also be involved, in co-ordination with state and district legal services committees, for the planning and implementation of the survey. Furthermore, the NALSA shall frame appropriate models (in the light of its experience in relation to other models for disbursement of compensation to victims of crime) for easy disbursement of compensation."

3. in this regard, survey guidelines along with time lines in consonance with provisions of MS Act 2013 and MS Ruies 2013 (copy enclosed) has been drafted and is attached herewith. A model for disbursement of compensation may also be formulated.

522/True copy//
✓

4. It is requested that suggestions / comments on the draft survey guidelines, in compliance of Hon'ble Court order, may be conveyed at the earliest to enable us to circulate the same to States / UTs for compliance and mention the same in compliance report to be filed before Hon'ble Supreme Court of India. It is further mentioned that the guidelines are to be finalized and circulated before 19.1.2024 in compliance with the Orders of Hon'ble Supreme Court of India.

Encls: As above

Yours faithfully,

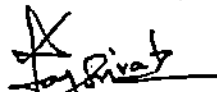

(Ajay Srivastava)

Economic Adviser

Tel No. 011-23022347

Email:- ajaysri@nic.in

//True copy//

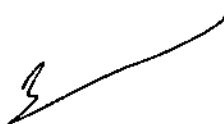

**TRAINING MANUAL FOR SURVEY OF
MANUAL SCAVENGERS**

2024

//True copy//

5

524

- Contents

1. Who is the manual for?	3
2. Prohibition of Employment as Manual Scavengers and Rehabilitation Act, 2013	3
2.1. Definition of Manual Scavengers and Insanitary Latrines	3
2.2. Legal provisions to prohibit Manual Scavenging	4
2.3. Social Entitlements for Manual Scavengers	4
3. Introduction to MS Survey as per the Supreme Court Judgment 2023	5
3.1. Existing provisions for Survey of Manual Scavengers in MS Act 2013	5
4. Survey Methodology/Process Flow 2024	8
4.1. Who will survey?	9
4.2. Who will check?	10
4.3. Who will validate?	10
5. IEC Campaign to be conducted for awareness generation on MS Survey 2024	10
6. Roles and responsibilities of all stakeholders	13
6.1. Role of Enumerator	15
6.2. Role of Local Authority	15
6.3. Role of District Level Survey Committee/State Level Survey Committee(DLSC/SLSC)	16
6.4. Role of National Legal Services Authority (NALSA)	16
7. Digital application for survey of persons engaged in manual scavenging	18
7.1. Who will do what?	18
7.2. How to create user login?	18
7.3. Orientation on usage of mobile and desktop application for enumerators	20
7.3.1. Using the handheld device and the BMS application	20
7.3.2. How to login and start survey through mobile application	21
7.3.3. How to login and start survey through desktop application	23
7.4. Error flagging and error resolving	25
7.4.1. Error flagging	25
7.4.2. Error resolving	28
7.5. Validation	32
7.5.1. Validation through mobile application	32
7.5.2. Validation through desktop application	40
Annexure-1	43

525
True copy

1. Who is the manual for?

This user manual is primarily designed for Local authorities, Enumerators, Overseers/Checkers and District Level Survey Committee.

- a. Local authorities are responsible for identification of insanitary latrines and manual scavengers which will set the foundation of survey. It is the responsibility of the local authorities to appoint the enumerators.
- b. Enumerators are responsible for conducting the surveys. The manual will provide them with clear instructions and tips on asking appropriate questions and to suggest the most effective methods to conduct the surveys.
- c. Overseers/Checkers are responsible for conducting 100% sample checks of the surveys conducted in the cities/towns/villages.
- d. District Level Survey Committee will monitor the survey of manual scavengers.

2. Prohibition of Employment as Manual Scavengers and Rehabilitation Act, 2013

The Prohibition of Employment as Manual Scavengers and their Rehabilitation Act (or MS Act), 2013¹, inter-alia, provides for:

- (i) Elimination of insanitary latrines;
- (ii) Prohibition of:
 - (a) Employment as Manual Scavengers;
 - (b) Hazardous cleaning of sewers and septic tanks; and
- (iii) Identification of insanitary latrines and demolish the same / convert it into sanitary latrines;
- (iv) Survey of Manual Scavengers and their rehabilitation.

2.1. Definition of Manual Scavengers and Insanitary Latrines

As per Section 2(1)(g) of the MS Act, 2013 manual scavenger has been defined as under:

"manual scavenger" means a person engaged or employed, at the commencement of this Act or at any time thereafter, by an individual or a local authority or an agency or a contractor, for manually cleaning, carrying, disposing of, or otherwise handling in any manner, human excreta in an insanitary latrine or in an open drain or pit into which human excreta from the insanitary latrines is disposed of, or on a railway track or in such other spaces or premises, as the Central Government or a State Government may notify, before the excreta fully decomposes in such manner as may be prescribed, and the expression "manual scavenging" shall be construed accordingly;

Explanation.-(a) "engaged or employed" means being engaged or employed on a regular or contract basis;

¹ As per MS Act, 2013, Section 4, 5, & 11

TRUE COPY

- *(b) a person engaged or employed to clean excreta with the help of such devices and using such protective gear, as the Central Government may notify in this behalf, shall not be deemed to be a 'manual scavenger';*

Section 2(1)(e) of the MS Act, 2013 defines insanitary latrine as under:

"insanitary latrine" means a latrine which requires human excreta to be cleaned or otherwise handled manually, either in situ, or in an open drain or pit into which the excreta is discharged or flushed out, before the excreta fully decomposes in such manner as may be prescribed:

Provided that a water flush latrine in a railway passenger coach, when cleaned by an employee with the help of appropriate devices and using such protective gear, as the Central government may notify in this behalf, shall not be deemed to be an insanitary latrine.

2.2. Legal provisions to prohibit Manual Scavenging

As per MS Act, 2013. Section 5, 6, 7, 8, 9 & 10 of the Act makes it mandatory for municipalities, cantonment boards and railway authorities to construct adequate number of sanitary community latrines within three years of this Act coming into force. If anyone employs a manual scavenger or constructs an insanitary latrine, he shall be penalised with imprisonment of up to one year or a fine of up to Rs.50, 000/- or both. The penalty for subsequent offences is higher. Every local authority or agency is prohibited from employing a person for hazardous cleaning (manual cleaning without protective gear and other safety precautions) of a sewer or a septic tank. This provision is applicable within a year of the Act coming into force. The penalty for violation is imprisonment for up to two years or a fine of up to Rs. Two lakh or both.

2.3. Social Entitlements for Manual Scavengers

As per Section 13 of MS Act, 2013, any person included in the final list of manual scavengers published shall be provided the following;

- a. a photo identity card, containing details of all members of his/her family dependents
- b. one-time cash assistance
- c. children of manual scavengers shall be entitled to scholarship as per the relevant scheme of the Central Government or the State Government or the local authorities
- d. a residential plot and financial assistance for house construction, or a ready-built house, with financial assistance, subject to eligibility and willingness of the manual scavenger, and the provisions of the relevant scheme of the Central Government or the State Government or the concerned local authority
- e. he/she, or at least one adult member of his/her family, shall be given, subject to eligibility and willingness, training in a livelihood skill, and shall be paid a monthly stipend of not less than three thousand rupees, during the period of such training
- f. he/she, or at least one adult member of his family, shall be given, subject to eligibility and willingness, subsidy and concessional loan for taking up an alternative occupation on a sustainable basis, in such manner as may be stipulated in the relevant scheme of the Central Government or the State Government or the concerned local authority.

527/True copy//
S

- g. he/she shall be provided such other legal and programmatic assistance, as the Central Government or State Government may notify in this behalf

**Provisions for Manual Scavengers provided by NSKFDC can be seen [here](#).*

3. Introduction to MS Survey as per the Supreme Court Judgment 2023

The Hon'ble Supreme Court order in WP (C) No. 324/2020 filed by Dr. Balram Singh announced in the judgement of PIL that the surveys conducted in 2013 and 2018, were not in accordance with the 2013 Act and Rules and thus cannot be considered as surveys. The absence of institutions under the 2013 Act and Rules were pointed to the inadequacies of the Survey process. The survey was conducted in the statutory towns and did not extend to rural areas. This has misjudged manual scavenging as an urban problem.

The discrepancies in data points result in inefficient enforcement of legislations and schemes formulated for relief & rehabilitation of manual scavengers. Considering the aforementioned, it was decided that the nationwide survey covering all the states & districts is a must to identify and come up with a robust database of manual scavengers & related households.

3.1. Existing provisions for Survey of Manual Scavengers in MS Act 2013

Section 11 of MS Rules, 2013 contains the provision of survey in urban areas by Municipalities and Local authorities, which is as follows:

11. (1) The local authority shall ensure that the persons conducting the survey of manual scavengers shall be adequately and appropriately trained by the local authority on the method and manner in which the survey shall be conducted and sensitized on the issue of manual scavenging.

(2) The State Level Survey Committee and the District Level Survey Committee shall carry out adequate campaigns at various levels especially in all such areas where insanitary latrines have been found during the survey of insanitary latrines.

(3) The local authority shall also associate community leaders or non-governmental organizations working for the welfare of Safai Karamcharis or sanitary workers in identification of manual scavengers.

(4) The local authority shall invite manual scavengers through awareness campaigns to declare themselves at the self-declaration centres and have their details verified during a period and at places, which shall be notified by the local authority.

(5) The lists of manual scavengers, if provided by the non-governmental organisations or any other persons or agency, shall be fully verified to identify manual scavengers.

TRUE COPY

528



(6) In case, there is discrepancy between the data of insanitary latrines or the number of manual scavengers thrown up by any person or organisation, the local authority shall order a house-to-house survey of insanitary latrines by the enumerators to know the names of manual scavengers servicing those insanitary latrines.

(7) Local authority shall also make efforts to identify manual scavengers by visiting the habitations of concentration of safaikaramcharis, sanitary workers or manual scavengers.

(8) Sample checks of the work done to be done by the enumerators ensuring 100% sample check in villages, cities and towns.

(9) Any person having objection either to the inclusion or exclusion of any name in the provisional list of manual scavengers in pursuance of Act, may within a period of fifteen days from the provisional publication, file an objection in the prescribed format specified by the concerned local authority

(10) After publication of the final list by the local authority no claim or objection on the list shall be accepted for being included or excluded in the list, provided that the manual scavenger shall be entitled to give self-declaration about his being a manual scavenger.

Section 12 of the MS Act, 2013 provides for application by an urban manual scavenger for identification, which is as under:-

12. (1) Any person working as a manual scavenger in an urban area, may, either during the survey undertaken by the Municipality in pursuance of section 11, within whose jurisdiction he works, or at any time thereafter, apply, in such manner, as may be prescribed, to the Chief Executive Officer of the Municipality, or to any other officer authorised by him in this behalf, for being identified as a manual scavenger.

(2) On receipt of an application under sub-section (1), the Chief Executive Officer shall cause it to be enquired into, either as part of the survey undertaken under section 11, or, when no such survey is in progress, within fifteen days of receipt of such application, to ascertain whether the applicant is a manual scavenger.

(3) If an application is received under sub-section (1) when a survey under section 11 is not in progress, and is found to be true after enquiry in accordance with sub-section (2), action shall be taken to add the name of such a person to the final list published under sub-section (6) of section 11, and the consequences mentioned in sub-section (7) thereof shall follow.

Section 14 of the MS Act, 2013 provides survey of manual Scavengers in Rural Areas by Panchayats which is as under:

True copy

529

14. If any Panchayat has reason to believe that some persons are engaged in manual scavenging within its jurisdiction, the Chief Executive Officer of such Panchayat shall cause a survey of such manual scavengers to be undertaken, mutatis mutandis, in accordance with the provisions of section 11 and section 12, to identify such person.

15. (1) Any person working as a manual scavenger, in a rural area, may, either during the survey undertaken by the Panchayat within whose jurisdiction he works, in pursuance of section 14 or at any time thereafter, apply, in such manner, as may be prescribed, to the Chief Executive Officer of the concerned Panchayat, or to any other officer authorised by him in this behalf, for being identified as a manual scavenger.

(2.) On receipt of an application under sub-section (1), the Chief Executive Officer shall cause it to be enquired into, either as part of the survey undertaken under section 14 or when no such survey is in progress, within fifteen days of receipt of such application, so as to ascertain whether the applicant is a manual scavenger.

//True copy//

✓

4. Survey Methodology/Process Flow 2024

The MS Rules 2013 highlight the methodology to conduct the survey. The Rules provide for specific authorities that include constitution of State Level Survey Committee (SLSC) and District Level Survey Committees under Rule 11, to perform detailed roles. All the States / UTs are required to constitute SLSC and DLSC as per the MS Rules, 2013

Constitution of Committees for conducting the MS survey:

S.No.	Composition of the District level survey Committee ²	
1	District Magistrate	Chairman
2	District level officer dealing with scheduled castes affairs	Member Secretary
3	District Statistical Officer	Member
4	District level officer of Urban Development/Local Self Government	Member
5	One Representative of Railway Authority	Member
6	Upto two representatives of Non-government organizations working for welfare of manual scavengers and Safai Karmacharis to be nominated by the District Magistrate	Member
7	Up to two community representatives of whom one should be a woman to be nominated by the District Magistrate	Member

S.No	Composition of the State Level Survey Committee ³	
1	Additional Chief Secretary or Principal Secretary, nominated by the State Government	Chairman
2	Principal Secretary/Secretary dealing with Scheduled Castes, if the Committee is chaired by Additional Chief Secretary. if Principal Secretary, Scheduled Caste Welfare himself is the Chairman then Director, Scheduled Castes Welfare.	Member Secretary
3	Director , Economics and Statistics	Member
4	Secretary, Urban Development Department / Local Self Government Department	Member
5	Regional Director, Census Operation	Member
6	One representative of Railway Authority	Member
7	Upto two representatives of Non-Government Organizations working for welfare of Manual Scavengers and Safai Karmacharis to be nominated by the State Government	Member
8	Upto two community representatives of whom one	Member

² As per Rule 11(2), 11(18) and 11(19) of the PEMSRA

³ As per Rule 10(12), 10(13) and 11 (2) of the PEMSRA

53 // True copy //

should be a woman to be nominated by State Government	
-------------------------------------------------------	--

Coverage: To ensure that survey does not suffer like last time, Survey would be conducted in all the districts across the country for insanitary latrines existing as on date and manual scavengers currently engaged with the same.

Methodology of Survey: As per MS rules, 2013, the survey of insanitary latrines and manual scavengers involved in cleaning of insanitary latrines is to be undertaken by the local authority⁴ through a self-declaration form attached in the annexure-1

- a. **Digital survey:** The survey to be conducted in a digital manner to ensure that the data is collected in cost effective, efficient and transparent manner as compared to a paper survey. This will be conducted through BMS Application developed for NAMASTE. A Beneficiary Management System (BMS) application that is currently being used for enumeration of workers engaged in hazardous cleaning under NAMASTE will be customised to be utilised for survey of manual scavengers. This application has modalities of quality checks and a district wise and state wise dashboarding also possible. The application also in-built functionalities of capturing photographs of the individuals and their requisite identity cards and geo-tagging locations.
- b. In case no manual scavenger is identified in the District, District Magistrate to upload the Nil information. This declaration that there are no manual scavengers identified in the district should be made in two local newspapers and a period of 15 days to be given for inclusion of any such individuals who have been inadvertently left out of the survey.
- c. The Aadhar details of manual scavengers to be captured in the survey. In case the scavengers do not have an aadhar card or need their card details to be updated, the same should be facilitated through Common Service Centres by respective local bodies.
- d. Training of Local Authority, Enumerators, Overseers and District Level Survey Committee: The training of local authority, enumerators, overseers and DSLC would be conducted on the digital application, survey questionnaire by NSKFDC through virtual conference and training of trainers would also be conducted as and when required.

4.1. Who will survey?

Selection of enumerators⁵ will be done by local authority for survey. These enumerators will be such who have experience of conducting digital surveys and interacting with vulnerable communities. These enumerators will be a mix of men and women to ensure that both male and female scavengers are identified.

⁴ Local authority means urban local body or Panchayat which is responsible for sanitation in its area of jurisdiction, cantonment board and railway authority

⁵ As per MS Rules, Enumerator means any person engaged by a local authority for the purpose of survey or verification of manual scavengers

4.2. Who will check?

The data collected will be checked by the Overseer⁶. As per MS Rules, the role of overseer is as follows:

Overseers will conduct sample checks of the surveys done by the enumerators. The sampling will be on the basis of random selection as follows:

- i. 100% check in villages.
- ii. 100% check in cities and towns having less than 1000 households with insanitary latrines.
- iii. 50% of the declarations, verified by each enumerator, shall be checked in towns or cities having 1000 to 9999 households with insanitary latrines.
- iv. 33% of the declarations, verified by each enumerator, shall be checked in towns/cities having 10000 or more households with insanitary latrines.
- v. In categories (iii) and (iv), if sample check of the work done by any enumerator reveals an error of >10%, a 100% check of his work shall be carried out by the supervisor.

4.3. Who will validate?

As per MS Rules, the validation of the survey will be done by the local authorities. The final list of surveyed Manual Scavengers will be published by the District Level Survey Committee (DLSC) at the district level.

5. IEC Campaign to be conducted for awareness generation on MS Survey 2024

- a. As a preparatory for conducting the survey of manual scavengers, wide publicity about the survey for identification of Manual Scavengers, its dates, etc., through Print, and audio-visual Media, outdoor publicity, etc. can be done so that the general public aware about the survey.
- b. The notice of survey should also be published in two local newspapers, one of which shall be in vernacular language.
- c. States and cities may use other channels of communicating the survey timelines and modalities such as rickshaw mounted loudspeakers or in existing solid waste door to door collection vehicles.
- d. Support of community leaders/activists, NGOs working for welfare of Safai Karmacharis in identification of wards/pockets having concentration of insanitary latrines.

Suggested IEC Activities may be conducted for Survey of Insanitary Latrines and Manual Scavengers

Stakeholder	Key Messages for IEC	Medium	Number	Location of the display as per the discretion of local authorities
Local Authority	1. Identification of insanitary Latrines & Manual Scavengers 2. Survey of Manual	<ul style="list-style-type: none">• Banners• Wall paintings• Posters/Flax/Flyer /Leaflet		

⁶As per MS Rules, "Overseers" means an officer engaged by a local authority to exercise the powers and perform the duties under these rules.

533 //True copy//
S

	Scavengers 3. Approval of the final list	• Audio announcement		
DLSC	1. Survey of Manual Scavengers 2. Publication of the final list of manual scavengers surveyed and sanitary toilets 3. Social entitlements to Manual Scavengers	• Banners • Newspaper advertisement • Street play		

IEC Examples: Posters and Vehicle Stickers

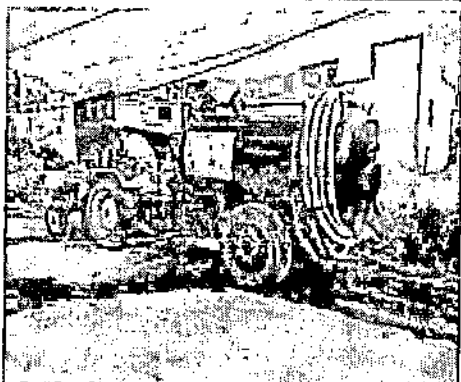
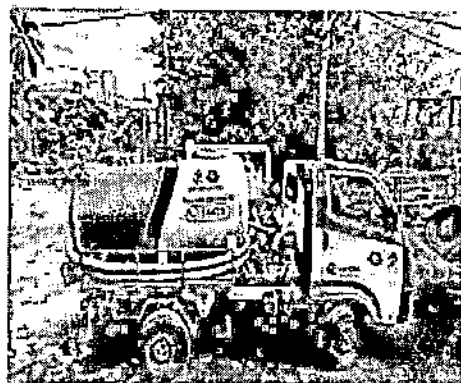
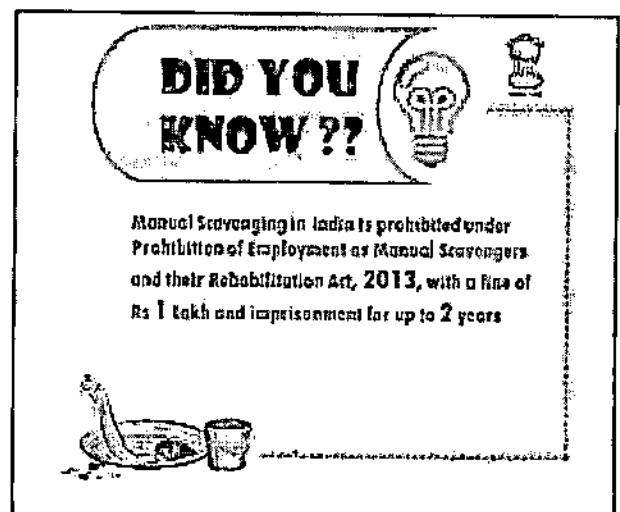
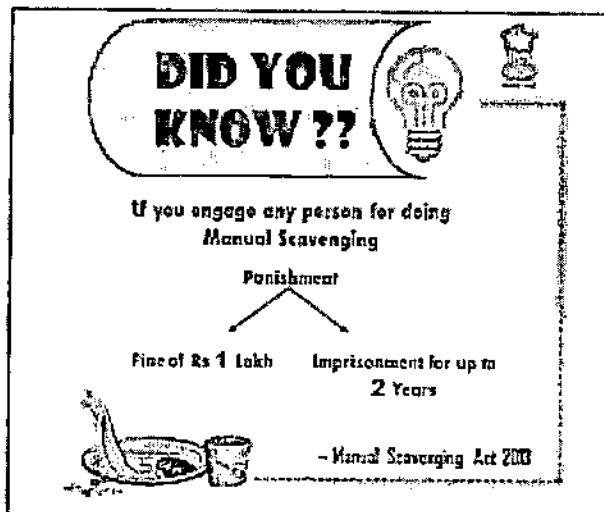

*All these samples and examples can be made and used in regional languages in context to the states

534 //True copy//

3

Examples of wall paintings from Garima Scheme

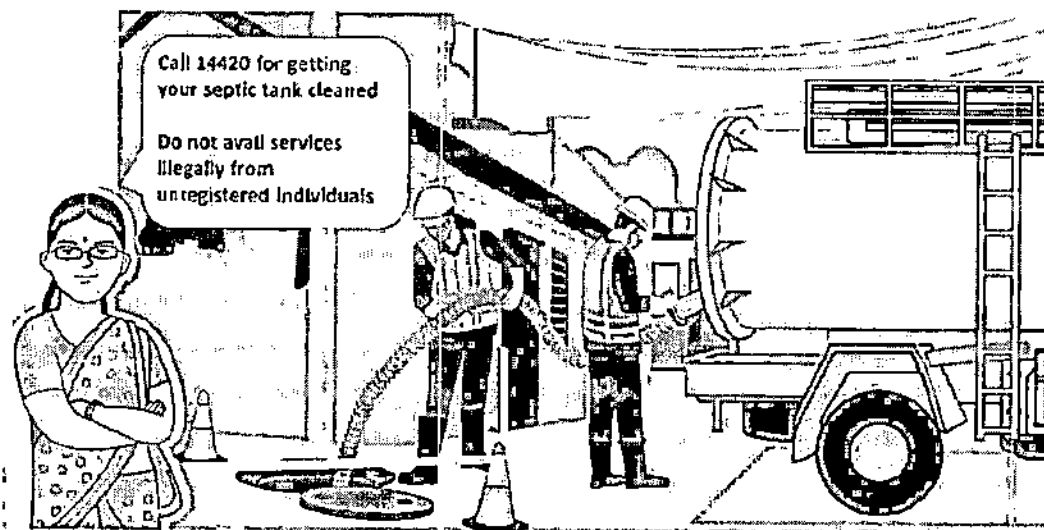
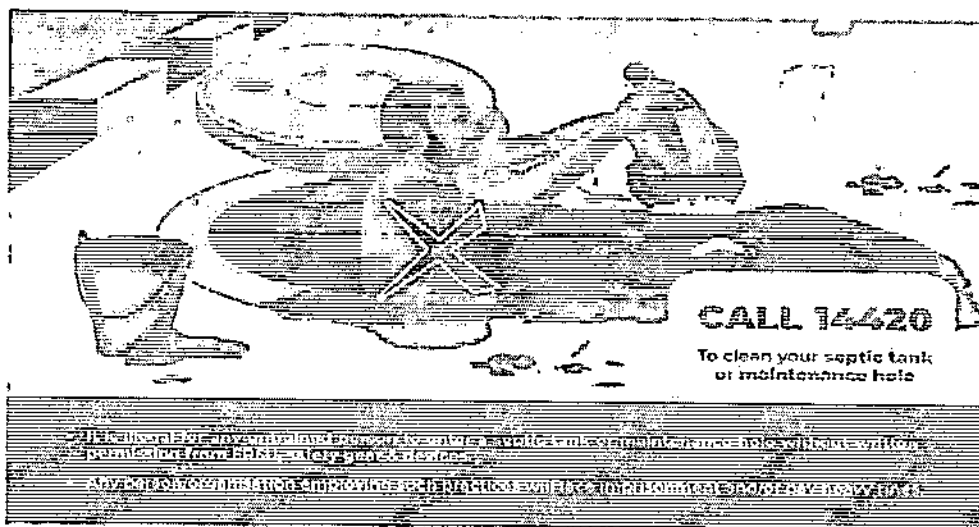

53 #True copy!!

Videos made for awareness generation:

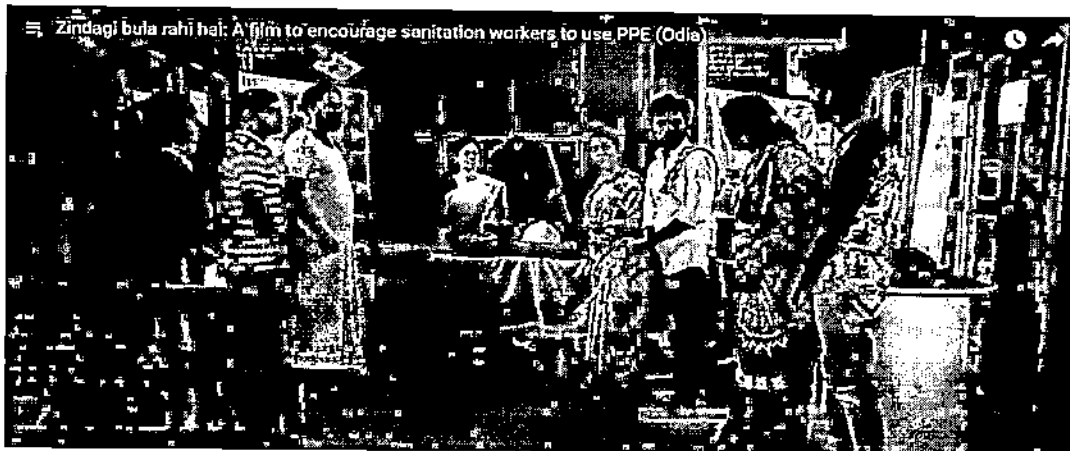

Zindagibularahihai: A film to encourage sanitation workers to use PPE

Hindi

https://www.youtube.com/watch?v=z4EMqbfcdmE&list=PLR9fFR1VfPABx98AJsOUmMyw_pQt-Z1h6&index=5

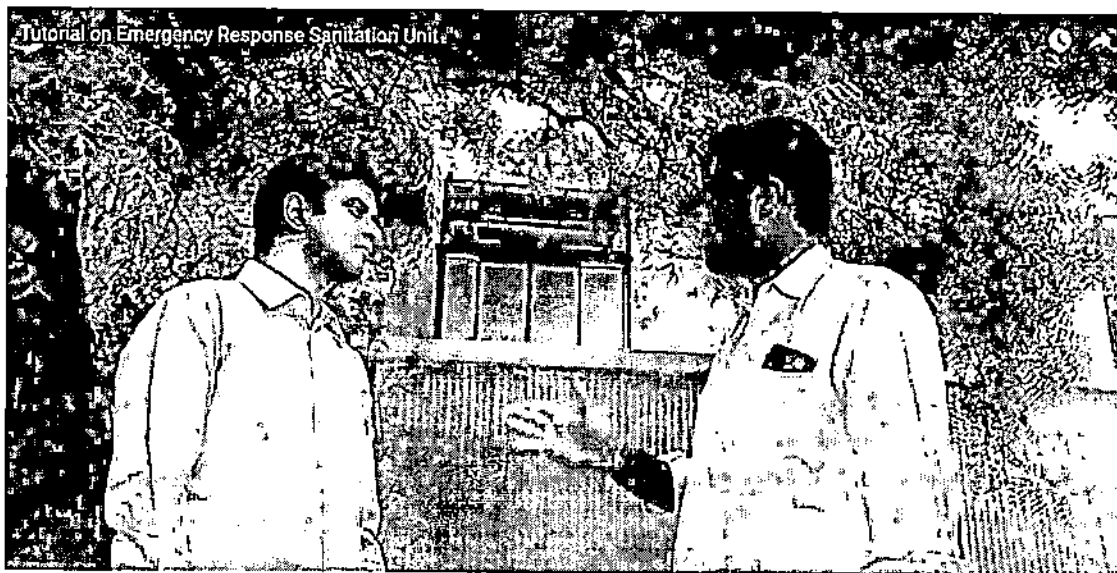

Tutorial on Emergency Response Sanitation Unit

Hindi

https://www.youtube.com/watch?v=xpdS5BulRi8&list=PLR9fFR1VfPABx98AJsOUmMyw_pQt-Z1h6&index=7

//True copy//



Tutorial 1_Profiling under NAMASTE Scheme



<https://www.youtube.com/watch?v=wjAlAi2s4qY>

//True copy//

✓

6. Roles and responsibilities of all stakeholders

6.1. Role of Enumerator

- a. The local authority shall also associate community leaders or non-governmental organizations working for the welfare of Safai Karamcharis or sanitary workers in identification of manual scavengers.
- b. The local authority shall invite manual scavengers through awareness campaigns to declare themselves at the self-declaration centres and have their details verified during a period and at places, which shall be notified by the local authority.
- c. The lists of manual scavengers, if provided by the non-governmental organisations or any other persons or agency, shall be fully verified to identify manual scavengers.

Guiding Principles for the Enumerator

- a. **No Promises to be made:** Do not make unrealistic promises to the respondents. Explain them about the survey and the benefits associated with the survey, and inform that while this survey will help in the enrolment for entitlements as per MS Act 2013, the appropriate department from the local authority will take actions for other needs.
- b. **Consent:** Informed consent must be taken before starting the survey
- c. **Empathy:** The survey includes capturing personal and sensitive information from the beneficiaries. The Surveyors should be mindful of this fact and respect their choices and decisions. Maintaining a polite and positive attitude for this survey is essential.
- d. **Privacy:** The Surveyors must respect the privacy of the data they collect, and it must be used only for profiling purposes. No leakage of photos or information will be tolerated.

6.2. Role of Local Authority⁷

As per Section 4 of MS Act, 2013 contains the role of local authorities in surveying the insanitary latrines and providing the community sanitary latrines

- a. Every local authority shall carry out a survey of insanitary latrines existing within its jurisdiction, and publish a list of such insanitary latrines, in such manner as may be prescribed, within a period of two months.
- b. Giving a notice to the occupier, within fifteen days from the date of publication of the list to either demolish the insanitary latrine or convert it into a sanitary latrine, within a period of six months. Provided that the local authority may for sufficient reasons to be recorded in writing and extend the said period not exceeding three months.

⁷ As per the MS Act, 2013 the local authority is being referred to the CEO of Municipalities/Municipal Corporations/Gram Panchayats.

- c. Municipalities, Cantonment Boards and railway authorities shall also construct adequate number of sanitary community latrines, within such period not exceeding three years from the date of survey list published.

As per Section 11 of MS Act, 2013 contains the role of local authorities in surveying the manual scavengers. Local authorities shall:

- a. ensure that the persons conducting the survey of manual scavengers shall be adequately and appropriately trained on the usage of digital Application and the enumerators should be sensitized on the issue of manual scavenging.
- b. associate community leaders or non-governmental organizations working for the welfare of Safai Karamcharis or sanitary workers in identification of manual scavengers.
- c. invite manual scavengers through awareness campaigns to declare themselves at the self-declaration centers and have their details verified during a period and at places, which shall be notified by the local authority.
- d. order a house-to-house survey of insanitary latrines in case, there is discrepancy between the data of insanitary latrines or the number of manual scavengers as emerges from any person or organization.
- e. make efforts to identify manual scavengers by visiting the habitations of concentration of safai karamcharis, sanitary workers or manual scavengers.
- f. notify the manner of publication of list during the survey of manual scavengers carried out under the Act.
- g. get the objections enquired into and hold a meeting, if necessary to finalise the list of manual scavengers in its jurisdiction.

6.3. Role of District Level Survey Committee/State Level Survey Committee(DLSC/SLSC)

As per the MS Rules 2013, the DLSC/SLSC's role is to:

- a. monitor and oversee the survey process at District/state level.
- b. distribute the materials for awareness campaign to designated place.
- c. arrange publicity through local newspapers etc. about the survey.
- d. distribute translated survey material to designated place under its jurisdiction.
- e. approve final list of manual scavengers for all towns, cities, and villages in the district.
- f. publish the final consolidated list of the manual scavengers in the district.

6.4. Role of National Legal Services Authority(NALSA)

The National Legal Services Authority (NALSA) has been constituted under the Legal Services Authorities Act, 1987 to provide free Legal Services to the weaker sections of the society and to organize Lok Adalats for amicable settlement of disputes.⁸

As per Hon'ble Supreme Court order in WP (C) No. 324/2020 filed by Dr. Bairam Singh, 'National Legal Services Authority (NALSA) plays a vital role in conducting the survey.

⁸<https://nalsa.gov.in/>

- a. NALSA shall be part of consultations for the policy formulations in regards with manual scavenging.
- b. It shall be involved in the co-ordination with state and district legal services committees, for the planning and implementation of the survey
- c. Furthermore, the NALSA shall frame appropriate models (in the light of its experience in relation to other models for disbursement of compensation to victims of crime) for easy disbursement of compensation.

//True copy//

✓

7. Digital application for survey of persons engaged in manual scavenging

Disclaimer: this section assumes that the digital enumeration will happen on the BMS application. UMC will require a formal letter from MOSJE to customize and adapt the existing NAMASTE BMS to suit the MS Survey. Based on finalization of the survey questionnaire, UMC will suggest a timeframe for the launch of the application.

The detailed guideline on the usage of the application with respect to the creation of the login ids and passwords at the local authority level for execution of survey in a digital mode would be provided based on the finalized questionnaire.

7.1. Who will do what?

	Roles
The local authority (ULB/ Gram Panchayat)	Creation of login Id and validation
ULB appointed enumerator	Enumeration and error resolving
Overseer	Error flagging
Validation	DLSC & SLSC (with view only access)

7.2. How to create user login?

The local authority (ULB/ Gram Panchayat) will create login ids for enumerators and overseers.

#	Steps	Image
1	The local authority must enter the login IDs and password provided by NSKFDC	
2	Local authority must complete their profile	

//True copy//

#	Steps	Image
3	Local authority must create IDs for enumerators	

ILLUSTRATIVE

4	To create users, click on "Users" under settings	
---	--------------------------------------------------	--

5	in Users page, all the ids created by the ULBs will be visible. To create "User", click on "+ Add New Users"	
---	--------------------------------------------------------------------------------------------------------------	--

ILLUSTRATIVE

//True copy//
542

#	Steps	Image
6	<p>If the ID is created for enumerator, select "Surveyor"</p> <p>For e.g. if the ID is "Kochis1", then their role should be selected as "Surveyor"</p>	
7	<p>After entering all the information. Click on "Create"</p>	
8	<p>You will redirect to "User" page. There you will be able to see all the IDs created</p>	

ILLUSTRATIVE
ILLUSTRATIVE

7.3. Orientation on usage of mobile and desktop application for enumerators

7.3.1. Using the handheld device and the BMS application

Enumerators should use a smartphone with the latest version of the survey application available on Google Play store. If they have already installed the app, update through notification/ pop-up for updates.

543 //TRUE COPY//
✓

Enumerators will be given User ID and password to use the application. Press the app icon on your smartphone and log in.

All devices should be fully charged before starting the surveys. Following steps must be taken to improve performance of the device on field:

1. Turn off Bluetooth and Wi-Fi when not in use;
2. Do not leave apps running in the background.
3. Turn off 'vibrate' alert.
4. The battery saver should be kept/ turned off during the survey as it may cause issues in the survey app.
5. Use power saver mode on the device if the battery is low; and
6. While using the survey app, ensure that GPS location is turned on. Follow these steps to turn on GPS location follow the below mentioned steps,
 - a. Unlock your phone.
 - b. Open the notification panel, on your phone.
 - c. Search for "location" option in the notification panel by scrolling down/ sideways, whichever may be applicable
 - d. Click on "location" option, this will activate the GPS location on your device

7.3.2. How to login and start survey through mobile application

#	Steps	image
Login can be done in two ways		
1	<p>Login using user ID and password</p> <p>Use Id and password as provided by the Local authority and tap 'Submit' to log in.</p>	

ILLUSTRATIVE

//True copy//

544

#	Steps	Image
2	<p>Or</p> <p>Login using One-time password (OTP) Use Id as provided by the Local authority.</p> <p>Click here, you will receive a 6-digit OTP on your Mobile number.</p> <p>Entre the OTP to login to the app</p>	

Change the language

1	<p>If the user wants the survey to be conducted in Hindi, click on "Profile" tab, and then click on "Language". This will show a list of languages it is available in and select preferred language.</p>	
---	----------------------------------------------------------------------------------------------------------------------------------------------------------------------------------------------------------	--

ILLUSTRATIVE

//True copy//

545

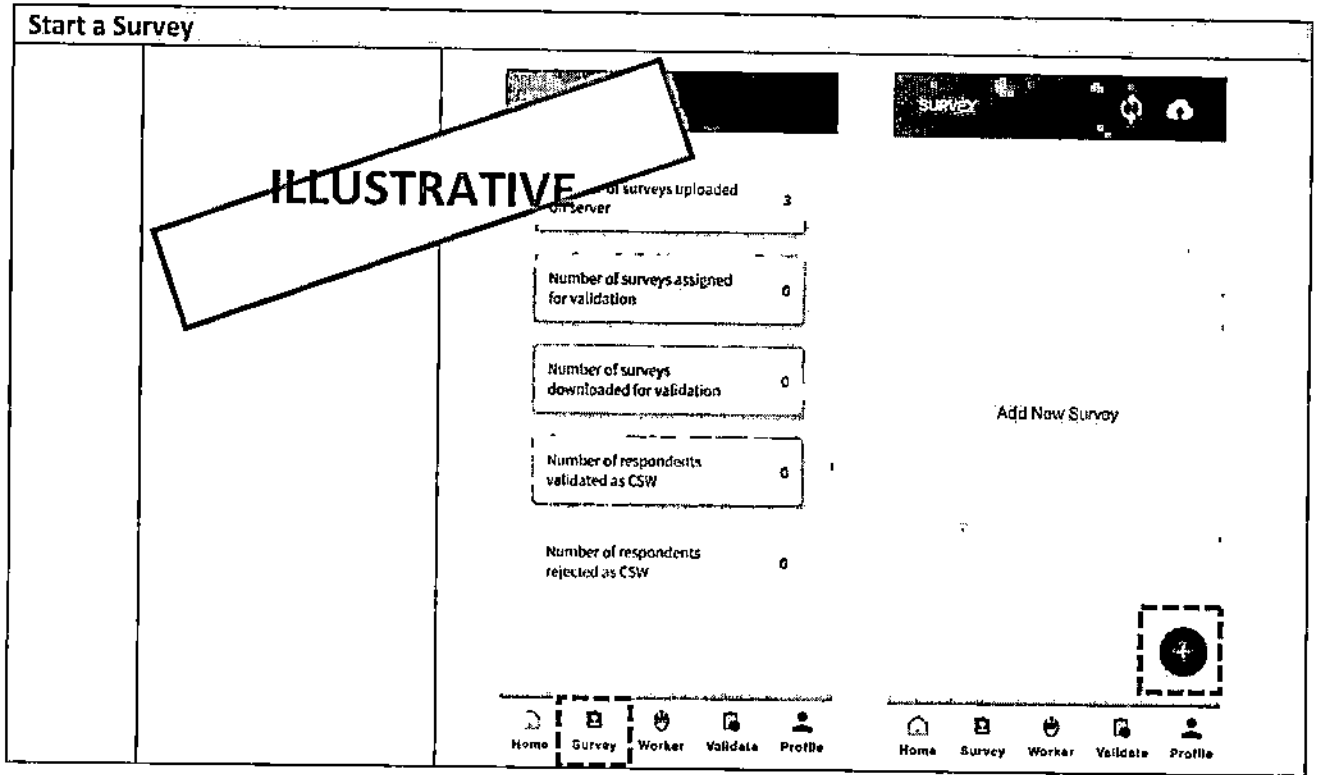

7.3.3. How to login and start survey through desktop application

#	Steps	Image
1	<p>Use Id and password a. Enter "captcha" as shown in the box</p>	

//True copy//

546

#	Steps	Image
2	If a user forgets their password, they can request a new one by providing their email ID.	

Change the language		
1	If the user wants the survey to be conducted in Hindi, click on tab as highlighted in the picture. This will show a list of languages it is available in and select preferred language.	

Start a new survey		
1	After logging in, proceed to the "New Survey" tab and begin the survey.	

//True copy//
547

7.4. Error flagging and error resolving

7.4.1. Error flagging

Error Flagging as per Section 11(8) of MS Act, is the process of checking the data collected during survey and identifying critical errors which can have an impact on validation of survey respondents or determining their eligibility to access various schemes. Check data collected by enumerators in every survey and identify all errors. It will be the responsibility of the overseer to flag the errors.

Follow the below steps mentioned to do error flagging:

1. Go to "Surveyed workers" page. This page will display all the surveys done by the Enumerators.

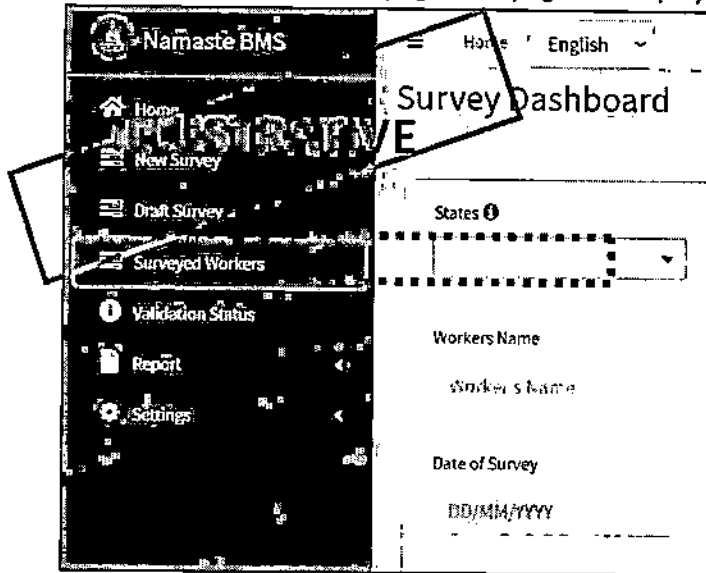

2. Click on "Info". This will show all the information filled by the enumerators for the respective workers

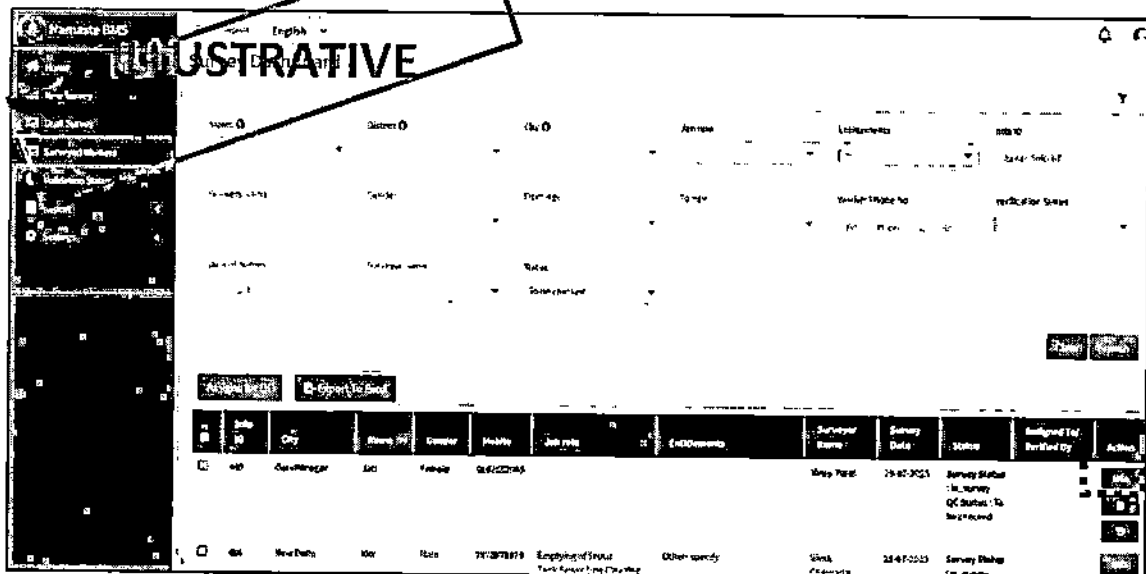

//TRUE COPY//

548

3

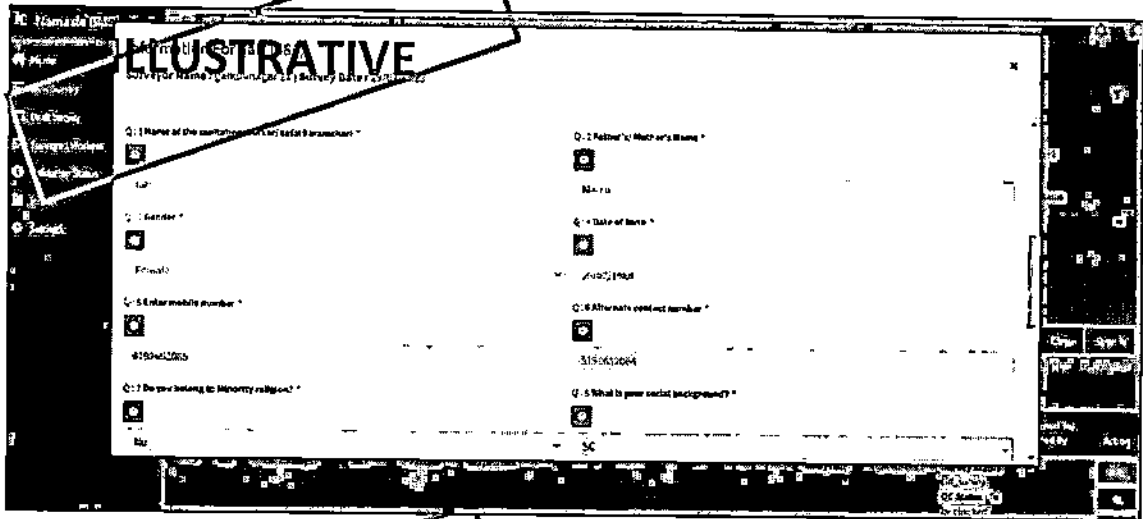

3. If there is no error in the form of enumerator, then click on "Accept"

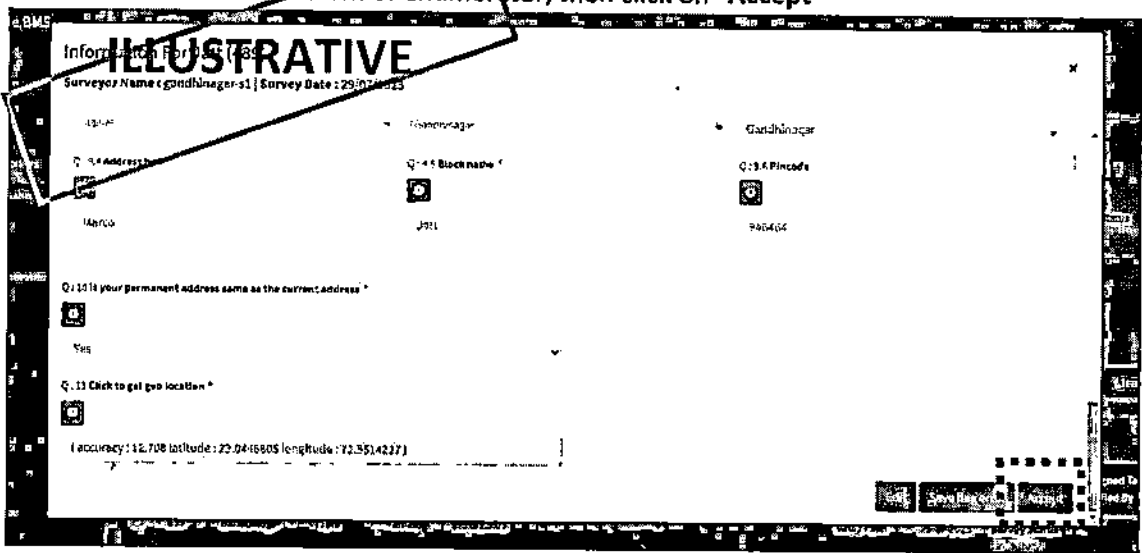

4. If there are any errors in the survey, then click on "i" and this will open up a pop up box to type in remarks

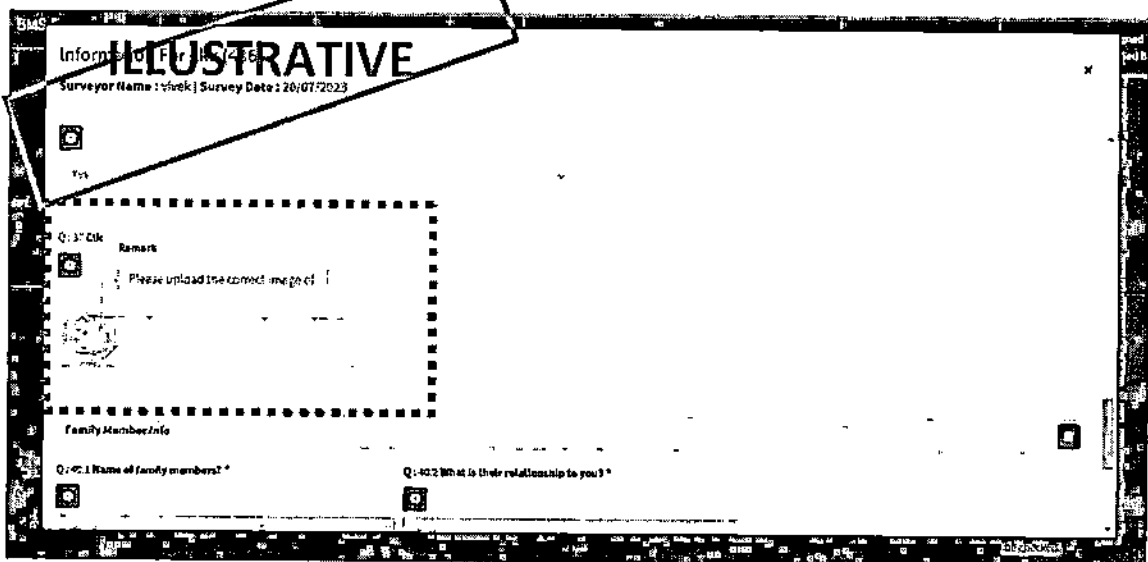

5. After entering the remarks, click on "Save" Button, by scrolling down on the pop up page

549 //True copy//

Note: please click an "Save", on each page, for eg. If you want to flag errors in "General" and "Social section", mark errors in "General" section and click "Save" and go to "Social section", mark errors and "click on "Save".

ILLUSTRATIVE

Information for All Users
Survey for Nurses (Incl) Survey Date: 26/07/2022

Family Member Info

Q: 40.1 Name of family member? *

Q: 40.2 What is their relationship to you? *

Q: 40.3 What is their gender? - Male *

Q: 40.4 How old are they? *

Q: 40.5 Special category if applicable *

Q: 40.6 Level of Education? *

For Consent Only

Save

6. Pop up message of saying "All remarks saved successfully" will appear.

ILLUSTRATIVE

Information for All Users
Survey for Nurses (Incl) Survey Date: 26/07/2022

Family Member Info

Q: 40.1 Name of family member? *

Q: 40.2 What is their relationship to you? *

Q: 40.3 What is their gender? - Male *

Q: 40.4 How old are they? *

Q: 40.5 Special category if applicable *

Q: 40.6 Level of Education? *

For Consent Only

Save

All remarks save successfully

7. The status of the survey will change to "Error Flagged"

//True copy//

550

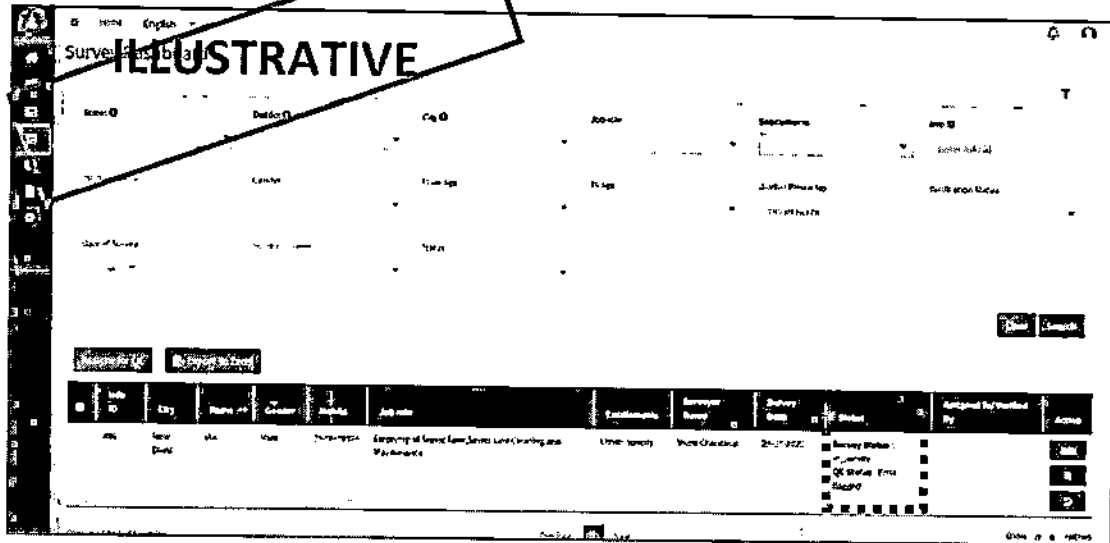

All the errors flagged will be sent to enumerator to resolve.

7.4.2. Error resolving

It is the responsibility of the enumerator to resolve all the errors flagged by the overseer. This process is called error resolving.

Follow the below steps mentioned to do error resolving:

#	Steps	Image
QC can be accessed in two ways		
1	<p>Go to the HOME page and click on the underlined number displayed next to "Number of surveys error flagged".</p> <p>OR</p> <p>Go to SURVEY page and click on QC option given at the top right corner.</p>	

ILLUSTRATIVE

//True copy//

All errors flagged in the survey need to be corrected or resolved

Step 1: The QC page will display all the surveys that are error flagged.

Step 2: To select a survey for editing, click on the tick sign.

Step 3: When the sign becomes green, a download option will be enabled.

Step 4: Click on the download option

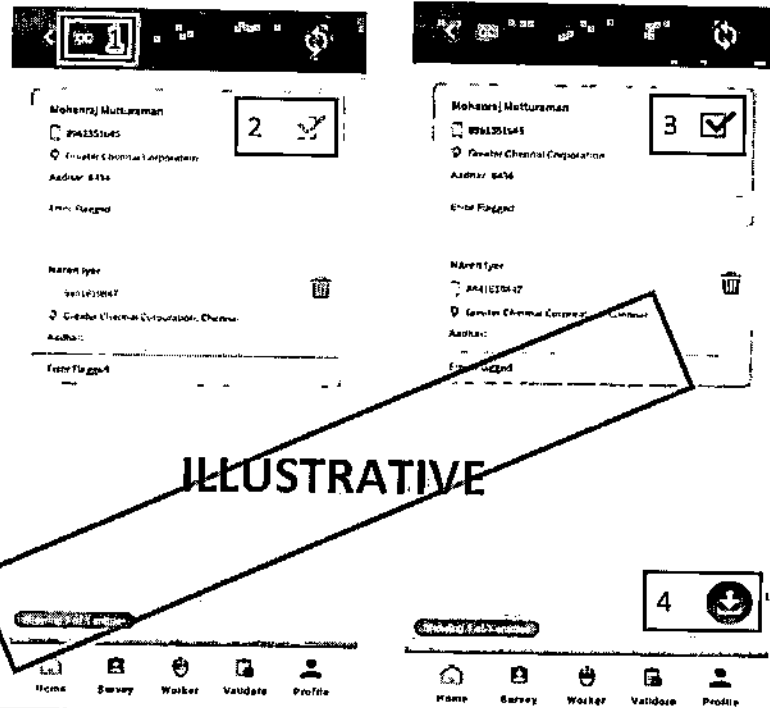

Once downloaded, the edit and delete button will be enabled. Click on the edit button to for rectifying the errors flagged

After downloading, if there is any problem in the downloaded file (example: data is missing for some questions), the form can be "deleted" and downloaded again

Step 5: The edit button opens a "QC Inputs" window within the survey. Only the questions that are flagged with error will be displayed.

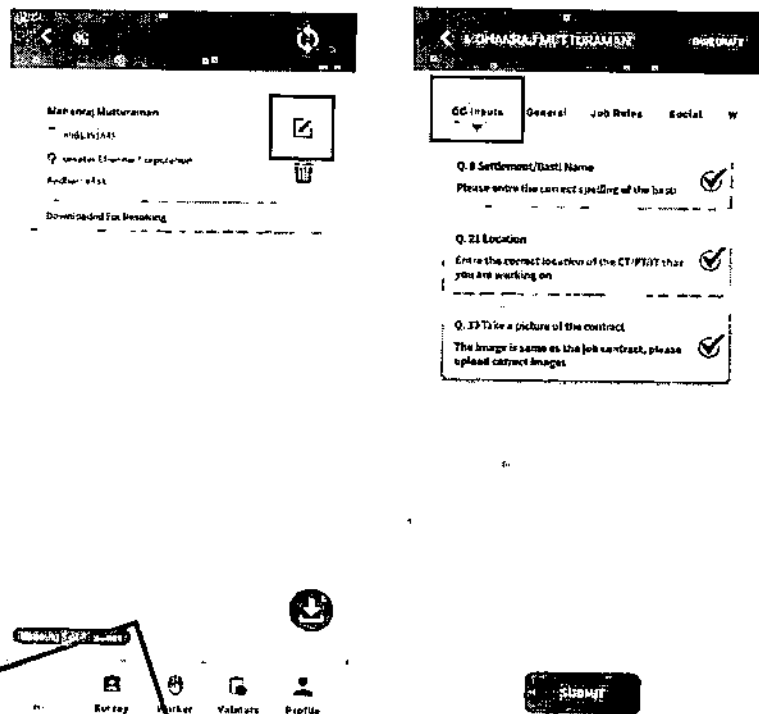

ILLUSTRATIVE

//True copy//

552

4	<p>Step 7: Click on the flagged questions to open the window to edit/ rectify the answers.</p>	
---	------------------------------------------------------------------------------------------------	--

5	<p>Step 8: Click on the red flag to get a prompt to read the comment or the reason for flagging the error.</p> <p>Step 9: After reading the comment, click on "OK" to proceed to edit</p>	
---	-------------------------------------------------------------------------------------------------------------------------------------------------------------------------------------------	--

ILLUSTRATIVE

//True copy//

553

6	<p>Step 10: Edit the answers as per the comments and click on the tick mark to turn them green</p>		
7	<p>Step 11: Once all the errors are resolved, click on the "SUBMIT" button.</p> <p>Step 12: Select "YES" to the prompt that appears after clicking on "SUBMIT"</p>		

ILLUSTRATIVE

//True copy//
S

<p>8</p> <p>Step 13: When back on QC page, click on the sync button.</p> <p>This will result in the survey being removed from QC section</p>	
----------------------------------------------------------------------------------------------------------------------------------------------	--

7.5. Validation

7.5.1. Validation through mobile application

It is the responsibility of the local authority to validate the surveyed persons engaged in manual scavenging.

Follow the below steps to validate persons engaged in manual scavenging using the mobile app:

#	Validation steps	Image
1	<p>Click on "WORKER" to land on page with the entire list of workers.</p> <p>ILLUSTRATIVE</p>	

//True copy//

555 ✓

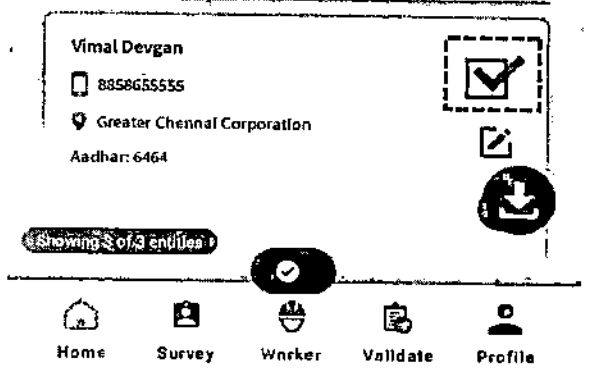
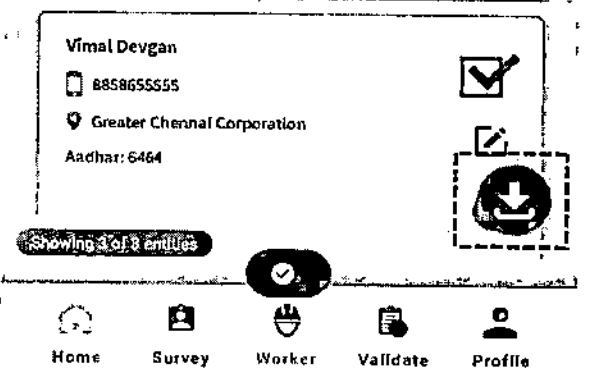
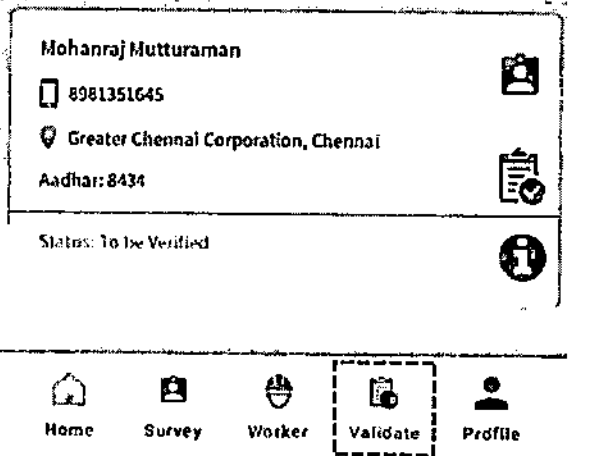
#	Validation steps	Image
2	To validate the worker, click on the tick mark to make it green	
3	Click on the download button to enable the survey for validation	
4	Click on "VALIDATE" tab to get to the page with all surveys that are downloaded for validation.	

ILLUSTRATIVE

556 //True copy//

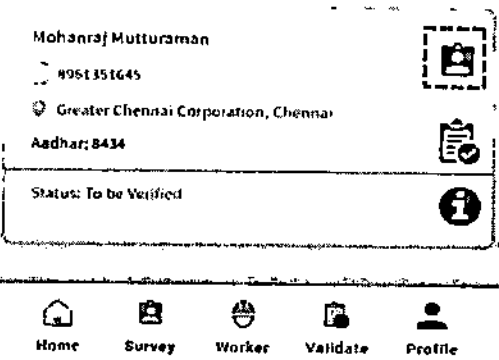
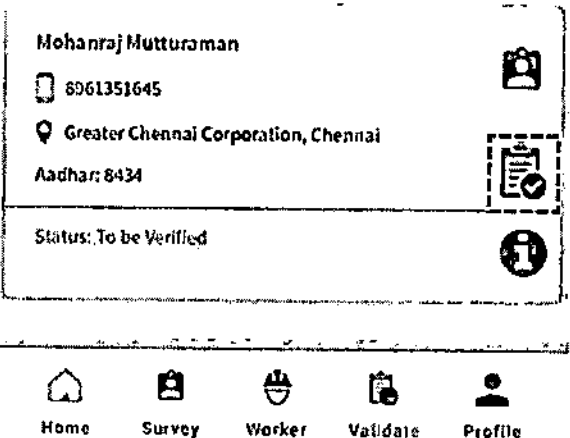
#	Validation steps	Image
5	Click on the image icon to see the picture of the worker.	
6	Click on notepad icon to validate the worker	

557 *True copy*

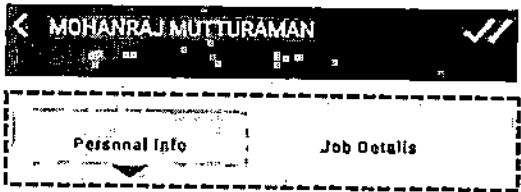
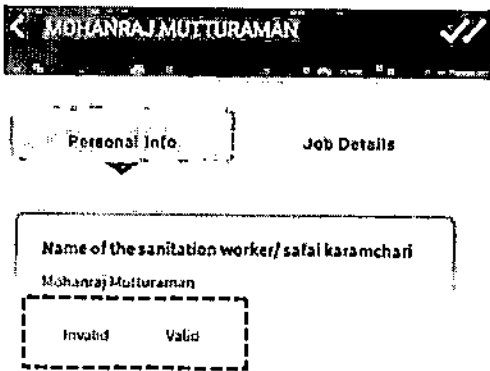
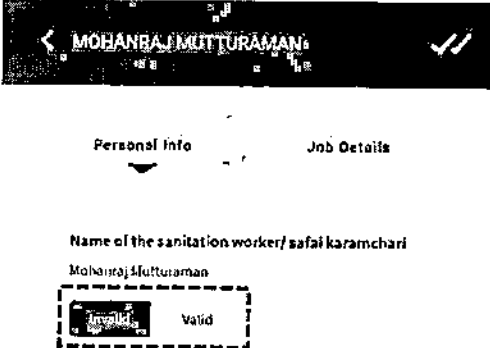
#	Validation steps	Image
7	The worker will be validated based on two categories: Personal Information and Job Role	
8	<p>Each question will have valid and invalid option with a set of reasons to select from</p> <p style="text-align: center; border: 2px solid black; transform: rotate(-10deg); padding: 10px;">ILLUSTRATIVE</p>	
9	<p>Questions: Name of the person engaged in manual scavenging</p> <p>To invalidate the workers, click on "Invalid"</p>	

558 // True copy!!

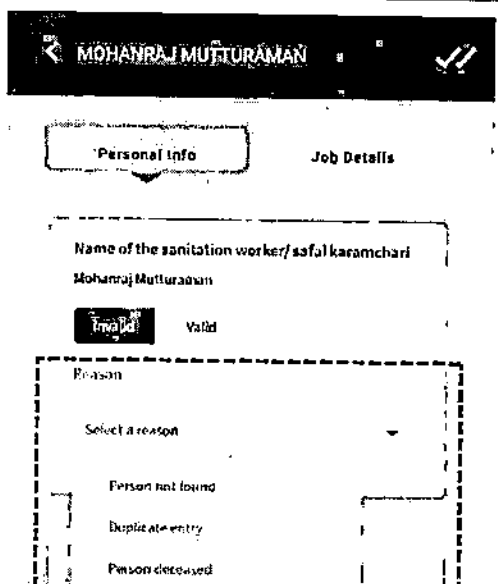
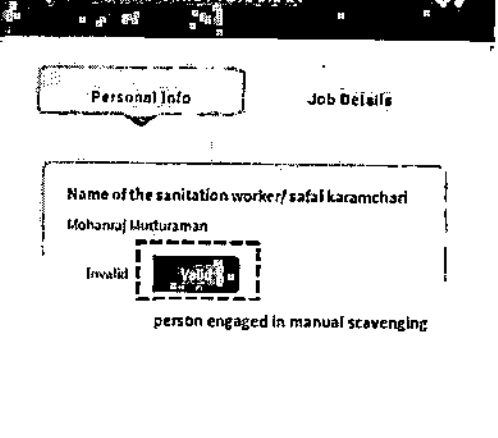
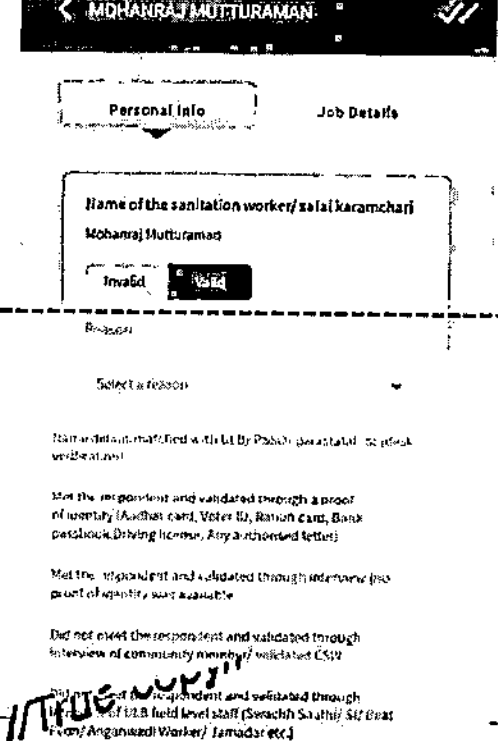
#	Validation steps	Image
10	<p>Select the appropriate reason from the drop down to invalidate (reasons mentioned below).</p> <ul style="list-style-type: none"> • Person Not Found • Duplicate Entry • Person deceased 	
11	<p>Questions: Name of the person engaged in manual scavenging</p> <p>To validate the workers, click on "Valid"</p>	
12	<p>Select the appropriate reason from the drop down to validate (reasons mentioned below).</p> <ul style="list-style-type: none"> • Name details matched with ULB/ PSSO/ parastatal list (desk verification) • Met the respondent and validated through a proof of identity (Aadhar card, Voter ID, Ration card, Bank passbook, Driving license, Any authorised letter) • Met the respondent and validated through Interview (no proof of identity was 	

ILLUSTRATIVE

#	Validation steps	Image
	<p>available)</p> <ul style="list-style-type: none"> • Did not meet the respondent and validated through interview of community member/ validated MANUAL SCAVENGERS • Did not meet the respondent and validated through Interview of ULB field level staff (Swachh Saathis/ SI/ Beat Peon/ Anganwadi Worker/ Jamadar etc.) 	
13	<p>Click on "Job Details" to enter that section.</p>	
15	<p>Questions: Are you engaged in manual scavenging?</p> <p>To validate the workers, click on "Valid" and then the drop down to find reasons to validate. Select the appropriate reason from the drop down (reasons mentioned below).</p> <ul style="list-style-type: none"> • Name and Aadhaar details matched with ULB/ PSSO/ parastatal list (desk verification) • Met the respondent and validated through a proof of employment (Job ID card, contract, salary slip etc.) • Met the respondent and validated through interview • Did not meet the respondent and validated through interview of community member/ validated MANUAL SCAVENGERS • Did not meet the respondent and validated through interview of ULB field level staff (Swachh Saathi/ SI/ Beat Peon/ Anganwadi Worker/ Jamadar etc.) <p>To invalidate the workers, click on "Invalid" and then the drop down to find reasons to invalidate. Select the appropriate reason from the drop down (reasons mentioned below).</p> <ul style="list-style-type: none"> • Family member of person engaged in manual scavenging not performing sanitation work 	

ILLUSTRATIVE

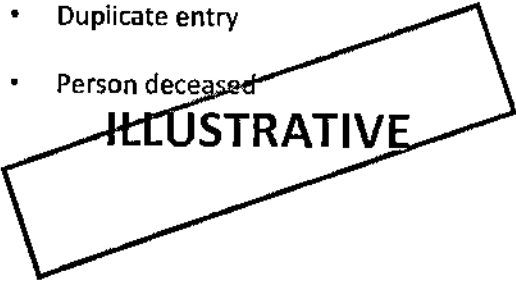
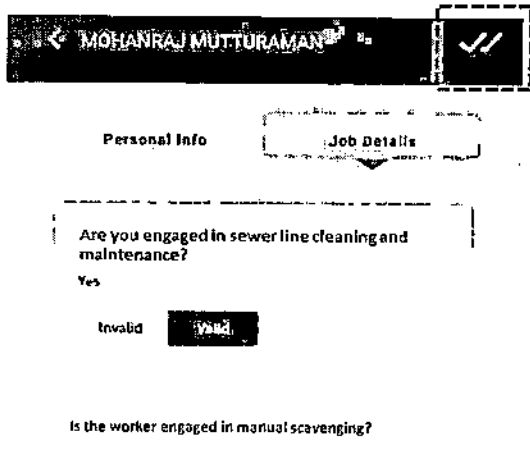
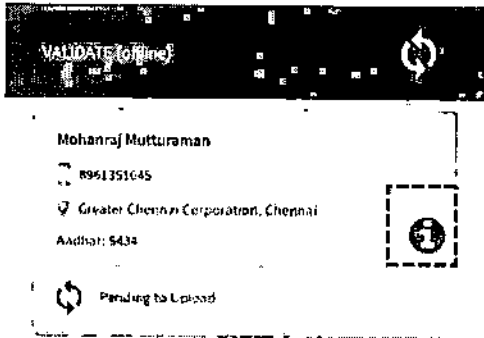
#	Validation steps	Image
	<p>themselves</p> <ul style="list-style-type: none"> • Did not meet the respondent and rejected through interview of ULB field level staff (Swachh Saathi/ SI/ Beat Peon/ Anganwadi Worker/ Jamadar etc.) • Not the person engaged in manual scavenging - working as a supervisor or contractor, or in another job role • Person not found • Duplicate entry • Person deceased 	
19	<p>Once validated or invalidated, click on the tick sign on the top right corner</p>	
20	<p>This will open the "VALIDATE (offline) page where the information of the workers can be viewed by clicking on the information icon</p>	

ILLUSTRATIVE

561 //True copy//

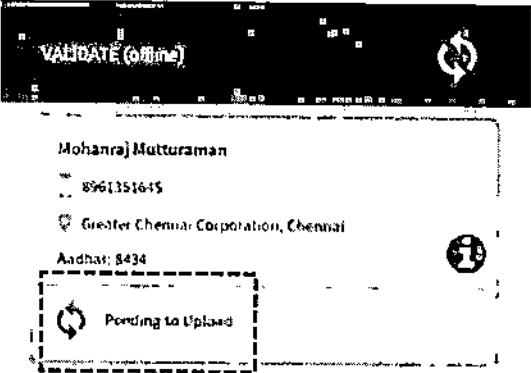
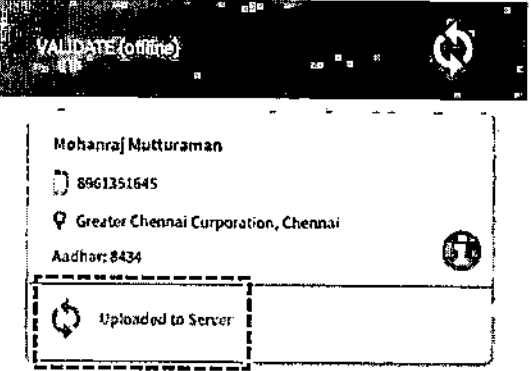
#	Validation steps	Image
21	The surveys will display "Pending to Upload". To upload them on server, click on the sync Button	
22	The surveys that are synced will display "Upioad to Server"	

ILLUSTRATIVE

//True copy//

562 *[Signature]*

7.5.2. Validation through desktop application

- 1 Click on "Validation status" page, this page will show all the surveys that have completed the error resolving stage and are ready to be validated by the ULB.

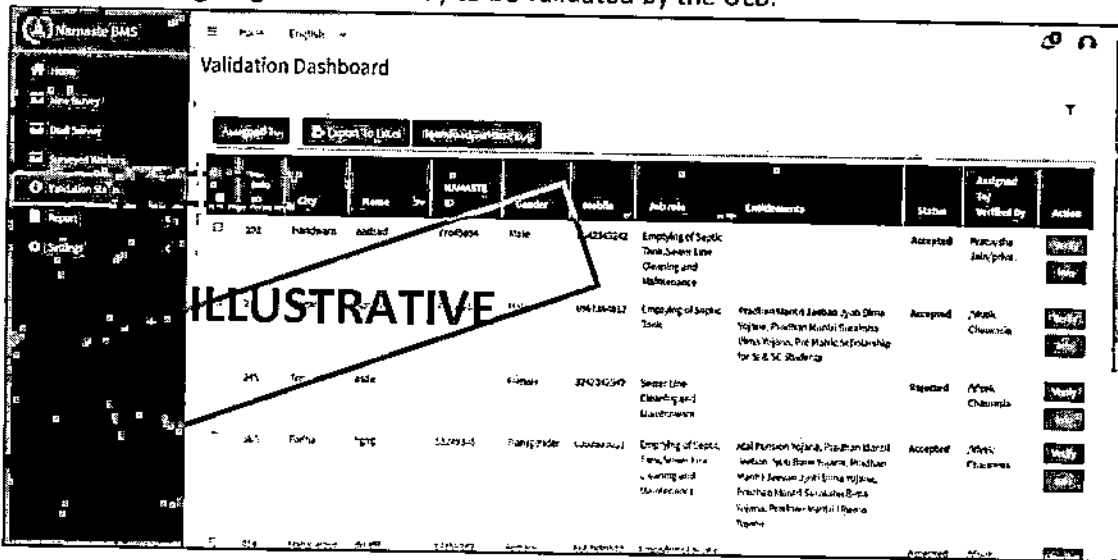

- 2 Click on "verify"

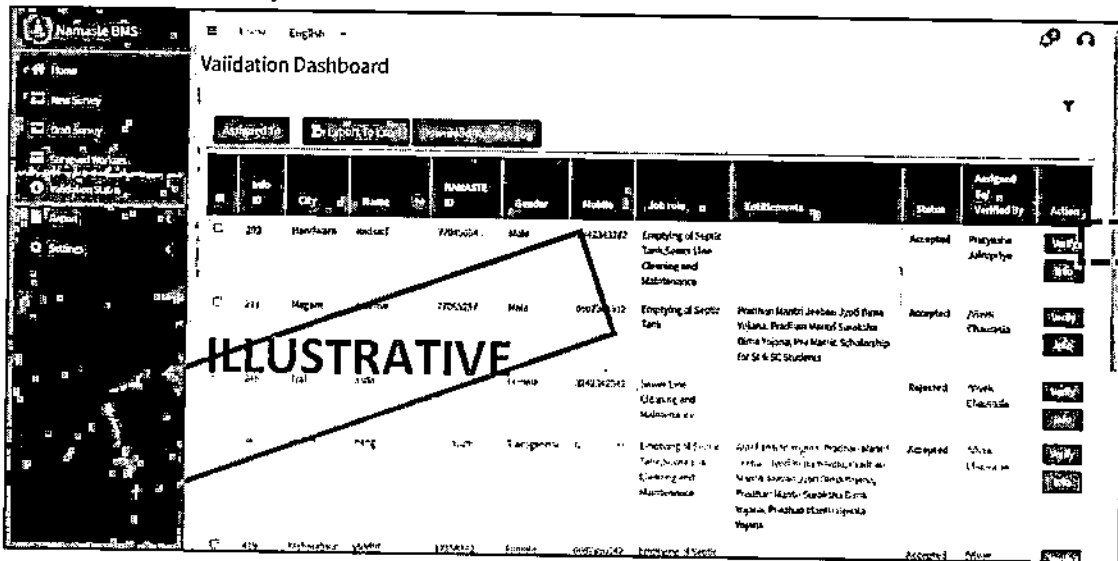

- 3 The worker will be validated based on two categories: Personal Information and Job Role

"/TRUE COPY"

[Handwritten signature]

Verify and approve the details for safailaramchari

Personal Info

Name	Value	Status	Reason
Name of the sanitation worker/safailaramchari	safailaramchari	Invalid	Valid

Job details

Close

Illustrative

4 Each question will have valid and invalid option with a set of reasons to select from

Verify and approve the details for safailaramchari

Personal Info

Name	Value	Status	Reason
Name of the sanitation worker/safailaramchari	safailaramchari	Invalid	Valid

Job details

Close

Illustrative

5 Questions: Questions: Name of the person engaged in manual scavenging
To validate the workers, click on "Valid"

Select the appropriate reason from the drop down to validate (reasons mentioned below).

- Name details matched with ULB/ PSSO/ parastatal list (desk verification)
- Met the respondent and validated through a proof of identity (Aadhar card, Voter ID, Ration card, Bank passbook, Driving license, Any authorised letter)
- Met the respondent and validated through interview (no proof of identity was available)
- Did not meet the respondent and validated through interview of community member/ validated MANUAL SCAVENGERS
- Did not meet the respondent and validated through interview of ULB field level staff (Swachh Saathis/ SI/ Beat Peon/ Anganwadi Worker/ Jamadar etc.)

6 Questions: Name of the person engaged in manual scavenging
To invalidate the workers, click on "Invalid"

TRUE COPY!!

564

Select the appropriate reason from the drop down to invalidate (reasons mentioned below).

- Person Not Found
- Duplicate Entry
- Person deceased

7 Click on "Job Details" to enter that section.

8 Questions: Are you engaged in manual scavenging?

To validate the workers, click on "Valid" and then the drop down to find reasons to validate. Select the appropriate reason from the drop down (reasons mentioned below).

- Name and Aadhaar details matched with ULB/ PSSO/ parastatal list (desk verification)
- Met the respondent and validated through a proof of employment (Job ID card, contract, salary slip etc.)
- Met the respondent and validated through interview
- Did not meet the respondent and validated through interview of community member/ validated MANUAL SCAVENGERS
- Did not meet the respondent and validated through interview of ULB field level staff (Swachh Saathi/ SI/ Beat Peon/ Anganwadi Worker/ Jamadar etc.)

To invalidate the workers, click on "invalid" and then the drop down to find reasons to invalidate. Select the appropriate reason from the drop down (reasons mentioned below).

- Family member of person engaged in manual scavenging, not performing sanitation work themselves
- Did not meet the respondent and rejected through interview of ULB field level staff (Swachh Saathi/ SI/ Beat Peon/ Anganwadi Worker/ Jamadar etc.)
- Not the person engaged in manual scavenging - working as a supervisor or contractor, or in another job role
- Person not found
- Duplicate entry
- Person deceased

9 Click on "Save changes"

10 Success message will be displayed based on the validation status of the worker.

//True copy//

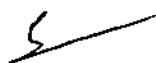

Annexure-1

{See rule 11(2)}

Self Declaration Form

Identification of the persons engaged in manual scavenging

(Office Use)

Photo of the person engaged in manual scavenging

- Name of the State: _____
- District: _____
- Municipality: _____ Town _____ Ward : _____
- Panchayat _____ Village _____

Family Photo of the person engaged in manual scavenging
(Picture post card size photograph 6"x4")

1. Name of the person engaged in manual scavenging: _____

2. Name of Father / Mother / Spouse: _____

3. Date of Birth _____ Age: _____

4. Sex : Male Female

5. Aadhaar Number of the person engaged in manual scavenging

6. Bank details
Name of Bank _____

Branch _____

IFSC Code _____

Account No. _____

56 (True copy))
↙

7. Details of Self and dependent family members:-

Household Profile

(Please give the names of the family members who live in your household starting with the manual scavenger)

Sl. No.	Name	Gender (M/F)	Age	Marital Status	Relationship with Identified Manual Scavenger	Educational /Skill Qualification	Current Occupation	Monthly income (Amt. in Rs.)	Requirement if any, for			Remarks
									Edu-cation	Skill Traini ng	Loan for Project	
1												
2												
3												
4												
5												
6												
7												

Marital Status: 1. Married 2. Unmarried 3. Divorced/Widow

Relationship: 1. Father 2. Mother 3. Brother 4. Sister 5. Grandfather 6. Grandmother 7. Father in Law 8. Mother in Law 9. Self 10. Son 11. Daughter 12. Others (Specify) _____

Education: 1. Illiterate 2. Primary 3. Middle 3. Secondary 4. 10+2 5. Graduate and above 6. Skilled

Occupation: 1. Agricultural Labour 2. Housewife 3. Student 4. Farmer 5. Wage Labourer 6. Self employed 7. Permanent Sanitary worker in Government 8. Contractual/Casual Sanitation Worker 9. Other Service/Job 10. Others (specify).....

567/True copy

8. Educational Status of the person engaged in manual scavenging : (Put a ✓ mark in the appropriate box)

(i) a) Literate b) Not literate

(ii) If literate, level of education:-

a) Studied: Class 1-5: Class 6-10: Class 11-12 : Class above 12:

9. Occupation :

ii) Carrying/disposing/cleaning of human excreta manually from insanitary latrine

ii) Cleaning untreated human excreta manually from: (a) open drain

(b) Raiiway Track (c) Pit Latrine

10. Status of Employment:-

I. Employed in:

(a) Prlvate:-

(i) Individual Household (ii) Community/ Group of Households

(iii) Contractor (iv) Institution like hospital, office etc.

(v) Others (specify) _____

(b) Centrai Government (c) State Government

(d) Municipal Corporation or Municipality or Panchayat

II. Employed on:

(a) Permanent basis (b) Temporary basis

(c) Contract basis (d) Jajmani

11. How long you have been in this Occupation: _____

12. Social Background:

(a) Whether SC/ST/OBCs/Others

(b) Caste (c) Sub Caste

(d) Religion

13. (a) Have you received any benefit from the Government rehabilitation schemes?

//True copy//

✓

568

(Put a ✓ mark in the appropriate box)

Yes	No

b) If yes, name of the scheme (Put a ✓ mark in the appropriate box):

	Name of the Schemes	Rupees
(1)	National Scheme for liberation and rehabilitation of scavengers (NSLRS)	
(2)	Self Employment Scheme for rehabilitation for manual scavengers (SRMS)	
(3)	Any other (Please specify the name of Scheme(s))	
(4)		

c) if yes, whether project funded through above scheme is running:

Yes	No	If yes, monthly income (Rs.)

d) Not known

14. (a) Are you engaged in any occupation other than scavenging? : Yes No

(b) If yes, specify: _____

15. Any other skills you possess:

- | | | | |
|-----------------|--------------------------|-------------------------|--------------------------|
| i) Construction | <input type="checkbox"/> | ii) Carpentry | <input type="checkbox"/> |
| iii) Driving | <input type="checkbox"/> | iv) Cooking | <input type="checkbox"/> |
| v) Tailoring | <input type="checkbox"/> | vi) Any other (specify) | _____ |

16. Alternative Occupation Proposed (Please specify): _____

Name and Address of the person engaged in manual scavenging: -----

----- Pin code-----

Contact Telephone/Mobile No. -----

True copy

Signature / Thumb Impression of the person engaged in manual scavenging

Name and date: -----

Signature of Enumerator, -----

Name and date: (with code No.): -----

Signature of Data Entry Operator, -----

Name and date (with code No.): -----

Signature of Supervisor, -----

Name and date (with code No.): -----

Details of Insanitary Latrine

1. Details of individual Insanitary Latrine (IIL):

Sl. No	Name of the owner of insanitary Latrine	Location of the		Monthly Salary/ wages of the Manual Scavenger (Rs.)	
		dry latrine	latrine from which excreta is being flushed into open drain	in cash	In food grains etc.

Total Number of the Individual Insanitary Latrines being cleaned by the person engaged in manual scavenging:

(Note: Please give detailed description of the individual Insanitary Latrine Cleaned by the person engaged in manual scavenging. In case you need to write extra information kindly photocopy this page and attach with the survey form)

2. Details of Community Insanitary Latrine (CIL):

Sl. No	Name of the owner (Organisation/ Agency) of Community Insanitary Latrine	Location of the		Monthly Salary/ wages of the Manual Scavenger (Rs.)	
		dry latrine	latrine from which excreta is being flushed into open drain	in cash	in food grains etc.

3. Detail of Open Drains (OD)/Railway Tracks/other spaces:

S.No	Location of Open Drains/Railway tracks/other spaces in which excreta from the insanitary latrines is being flushed	Salary/wages of the manual scavengers	
		In cash (Rs.)	in kind (Rs.)

(Note: if the number of involved manual scavengers in OD is more than one then please fill up a separate form for each of the person engaged in manual scavenging)

✓
True copy!!



571

File No.K-11036/2/2022-SCD-V
 Government of India
 Ministry of Social Justice and Empowerment
 (Department of Social Justice and Empowerment)

Shastri Bhawan, New Delhi
 Date:-18th, January, 2024

To,
 Additional Chief Secretary/Principal Secretary/
 Secretary/Additional Secretary/Incharges
 Social Welfare Department/SC/OBC Welfare Department
 All States/UTs as per list

Subject:- Implementation of Hon'ble Supreme Court order dated 20.10.2023 in WP (C) No. 324/2020 filed by Dr. Balram Singh-reg.

Respected Madam/Sir,

I am directed to refer to the subject mentioned above and to enclose herewith order dated 20.10.2023 in WP (C) No. 324/2020 filed by Dr. Balram Singh wherein Hon'ble Supreme Court has directed as under:-

"The Union, State and Union Territories are hereby required to set up scholarships to ensure that the dependents of sewer victims (who have died or might have suffered disabilities) are given meaningful education."

2. In context with the above, all States/UTs are requested to comply with the directions of the Hon'ble Supreme Court in letter and spirit. Appropriate action regarding including *the dependents of sewer victims (who have died or might have suffered disabilities) under the Component-II of the Centrally Sponsored Pre-Matric Scholarship Scheme for SC & Others may be taken in compliance of directions of Hon'ble Supreme Court.*

3. This issues with the approval of HMSJE.

Encl:- as above

Yours faithfully,

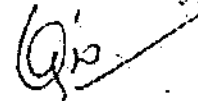

(Gottimukkala Vijay Kumar)
 Under Secretary to the Govt. of India
 Email:-g.vijaykumar@nic.in

Copy to:-

- (i) The Chief Secretary of All the States/UT's
- (ii) Additional Chief Secretary/Principal Secretary/ Secretary/ Incharges School Education Department All States/UTs as per list to comply with the orders of the Hon'ble Supreme Court in letter and spirit
- (iii) Commissioner/Director Social Welfare Department/SC/OBC Welfare Department All States/UTs as per list to comply with the orders of the Hon'ble Supreme Court in letter and spirit
- (iv) The Economic Adviser, D/o SJE, (Kind attention:- Sh. Ajay Srivastava)

//True copy//



सत्यमेव जयते

Annexure - XI
भारत सरकार

GOVERNMENT OF INDIA

राष्ट्रीय सफाई कर्मचारी आयोग

सामाजिक न्याय एवं अधिकारिता मंत्रालय

National Commission for Safai Karamcharis
MINISTRY OF SOCIAL JUSTICE & EMPOWERMENT

No. 11059/04/2023/R&D/

Dated: 16.01.2024

To

The Deputy Secretary,
Ministry of Social Justice & Empowerment,
Department of Social Justice & Empowerment,
604, A-Wing, Shastri Bhawan,
New Delhi.

Sub: Status of Vigilance Committee, State Monitoring Committee &
Constitution of State level Commission for Safai Karamcharis/agencies
designated to look after the work of State level Commission-reg.

Sir,

I am directed to refer to your letter dated 15.01.2024 and direction given
in the meeting on 15.01.2024 on the above mentioned subject. The requisite
information is hereby enclosed for your kind information and necessary action
please.

Encl: As above.

Yours faithfully

Ankush
16/1/24

(Ankush Chugh)

Assistant Director (R&D)

//True copy//

573

आर.के.खंडेलवाल भा.प्र.से.

सचिव

R.K.Khandelwal IAS

Secretary



सत्यमेव जयते

भारत सरकार

राष्ट्रीय सफाई कर्मचारी आयोग

सामाजिक न्याय एवं अधिकारिता मंत्रालय

'बी' विंग, चतुर्थ तल, लोकनायक भवन, खान मार्केट, नई दिल्ली-110 003

GOVERNMENT OF INDIA

NATIONAL COMMISSION FOR SAFAI KARAMCHARIS

MINISTRY OF SOCIAL JUSTICE & EMPOWERMENT

'B' Wing, 4th Floor, Lok Nayak Bhawan, Khan Market, New Delhi-110 003

Tel. : 24649352, Fax : 24648922

E-mail : socy-ncsk@gov.in

D.O. No. 11059/04/2023-R&D/34

Dated: 9 Jan' 2024

Dear Chief Secretary,

As you are aware, as per provisions of section 31 of the MS Act, 2013 National Commission for Safai Karamcharis is mandated to monitor the implementation of the MS Act, 2013 and to advise the Central and State Governments for the effective implementation of the provisions of this Act.

The Act provides for setting up of various Commission & Committees at various levels as given below:

- a. Section 32 of the Act: it provides for State Government by notification, to designate a State Commission for Safai Karamcharis or a State Commission for the Scheduled Castes or such other statutory or other authority, as it deems fit, to perform, within the State, mutatis mutandis, the functions specified in sub-section(1) of section 31.

Though action has been taken in this regard by many State/UT Governments. However, some of the States(named below) are yet to take action in this regard.

Name of States/UTs where no commission formed or Authority designated:

- | | |
|---------------|-----------------|
| i) Gujarat | vi) Telengana |
| ii) Jharkhand | vii) Chandigarh |
| iii) Manipur | viii) Ladakh |
| iv) Meghalaya | ix) Lakshadweep |
| v) Nagaland | |

- b. Section 24 of the MS Act, 2013: it provides for every State Government to constitute a Vigilance Committee for each district and Sub-Division which shall function as per provisions of Section 25 of the Act.

Further, similarly Section 26 of the Act provides for constitution of State Monitoring Committees which shall function as per Section 27 of the MS Act, 2013.

Although many State/UT Govts have formed these Committees but still some State/UT Governments are yet to form these committees(named below):

- | | |
|--------------------------------------|-------------|
| i) Arunachal Pradesh | iv) Ladakh |
| ii) Dadra Nagar Haveli & Daman & Diu | v) Manipur |
| iii) Jammu & Kashmir | vi) Mizoram |

- c. Further it has been observed that regular meetings of these Committees are not held and, some of these Committees have vacancies since long.

2. National Commission for Safai Karamcharis is also associated with the monitoring of the implementation of Supreme Court's Judgment dated 27.03.2014 in W.P. no. 583 of 2003 which directed to "identify the families of all persons who have died in sewerage work(manhole, septic tanks) since 1993 and award compensation of Rs. 10 lakhs for each such death to the family

Cont....2/-

de
Sent through
emails also

//True copy

574

members depending on them". In this context Hon'ble Supreme Court has recently issued revised directions dated 20.10.2023 in W.P no. 324 of 2020 filed by Dr. Bairam Singh vs Union of India. The copy of the aforesaid Judgment/directions is available in public domain at www.ncsk.gov.in. The next date of listing of the case is 01.02.2024.

3. The Court has, inter-alia amongst others, given the following directions in the Judgement dated 20th October, 2023:

- "The Union, State and Union Territories are hereby directed to ensure coordination with all the commissions (NCSK, NCSC, NCST) for setting up of state level, district level committees and commissions, in a time bound manner. Furthermore, constant monitoring of the existence of vacancies and their filling up shall take place. [Para 96(12)]".
- The NCSK, NCSC, NCST and the Secretary, Union Ministry of Social Justice and Empowerment, shall, within 3 months from today, draw modalities for the conduct of a National Survey. The survey shall be ideally conducted and completed in next one year.

4. Therefore as per Judgement of Hon'ble Supreme Court dated 20.10.2023, following actions are required to be taken by the States/UTs Govts:

- To take immediate action in forming State Commission/designate an agency, form various committees and also ensure their regular meetings and review of vacancies etc. so that they can work effectively.
- To ensure fresh survey of Manual scavengers in all the states, State Level Survey Committee and the District level Survey Committees are required to be formed immediately for conduct of survey under the prescribed timelines according to Rule 2 (c) and 2 (j) of MS Rules 2013.
- Advance preparations which includes adequate awareness campaigns at various levels, training & sensitization of persons to be employed for conduct of survey, educational modules, Manual/Agenda preparations etc. may also be taken on an urgent basis.

5. It is to be noted that the Ministry of Social Justice & Empowerment is in the process of circulating the draft guidelines for Survey to the States/UTs.

6. I shall be grateful if you could personally intervene in this matter and issue necessary directions to the concerned authorities for ensuring immediate action on the issues involved and to submit an action taken report to the Commission.

Yours Sincerely,

sd/-
(R.K Khandelwal)

The Chief Secretaries of all States as per list

Copy to:

i) Secretary, Social Justice & Empowerment

✓ ii) All Principal Secretaries/Secretaries, Dept. of Social Welfare for information & necessary action.

sd/-
9/1/24
(R.K Khandelwal)

575 ITMIE CORV//

Status of Vigilance Committees in the States (As on 31.12.2023)

	States/UTs that have constituted Vigilance Committee		States/UTs that have not informed about Constitution of Vigilance Committee
1	Andaman & Nicobar Islands	1	Dadra & Nagar Haveli and Daman & Diu
2	Andhra Pradesh	2	Jammu & Kashmir
3	Arunachal Pradesh	3	Ladakh
4	Assam	4	Manipur
5	Bihar	5	Mizoram
6	Chandigarh		
7	Chhattisgarh		
8	Delhi		
9	Goa		
10	Gujarat		
11	Haryana		
12	Himachal Pradesh		
13	Jharkhand		
14	Karnataka		
15	Kerala		
16	Lakshadweep		
17	Madhya Pradesh		
18	Maharashtra		
19	Meghalaya		
20	Nagaland		
21	Odisha		
22	Puducherry		
23	Punjab		
24	Rajasthan		
25	Sikkim		
26	Tamil Nadu		
27	Telangana		
28	Tripura		
29	Uttar Pradesh		
30	Uttarakhand		
31	West Bengal		

576
//True copy//

Status of State Monitoring committees in the State (As on 31.12.2023)

States/UTs that have constituted State Monitoring Committee		States/UTs that have not informed about Constitution of State Monitoring Committee	
1.	Andaman & Nicobar Islands	1	Arunachal Pradesh
2.	Andhra Pradesh	2	Jammu & Kashmir
3.	Assam	3	Ladakh
4.	Bihar	4	Manipur
5.	Chandigarh	5	Mizoram
6.	Chhattisgarh		
7.	Dadra & Nagar Haveli, Daman & Diu		
8.	Delhi		
9.	Goa		
10.	Gujarat		
11.	Haryana		
12.	Himachal Pradesh		
13.	Jharkhand		
14.	Karnataka		
15.	Kerala		
16.	Lakshadweep		
17.	Madhya Pradesh		
18.	Maharashtra		
19.	Meghalaya		
20.	Nagaland		
21.	Odisha		
22.	Puducherry		
23.	Punjab		
24.	Rajasthan		
25.	Sikkim		
26.	Tamil Nadu		
27.	Telangana		
28.	Tripura		
29.	Uttar Pradesh		
30.	Uttarakhand		
31.	West Bengal		

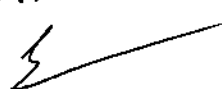
577 //True copy//

List of State Commission for Safai Karamcharis /Designated Agencies as on 31.12.2023

State Commission for Safai Karamcharis		Agenoles Designated to look after the work of State Commission for safai Karamcharis	
1	Delhi Commission for Safai karamcharis New Delhi.	1	Andaman & Nicobar Statutory Authority for Safai Karamcharis.
2	Haryana State Safai Karamcharis Commission, Punchkula.	2	Andhra Pradesh State Commission for Scheduled Castes.
3	Karnataka State Safai Karamcharis Commission, Bangluru.	3	Assam Backward Classes Commission, Dispur.
4	Madhya Pradesh State Safai Karamcharis Commission, Bhopal.	4	Bihar Mahadalit Vikas Mission, Patna.
5	Maharashtra State Safai Karamcharis Commission, Mumbai.	5	Chattisgarh State Scheduled Caste Commission, Raipur.
6	Punjab State Safai Karamcharis Commission, Mohali, Punjab.	6	Dadra & Nagar Haveli, Daman & Diu SC/ST, OBC & Minorities Financial and Development Corporation Ltd. Siivassa.
7	Rajasthan State Safai Karamcharis Commission, Jaipur.	7	Goa State Commission for Scheduled Caste And Scheduled Tribes, Panji, Goa.
8.	Uttarakhand State Commission for Safai Karamcharis Dehradun, Uttarakhand.	8	Himachal Pradesh State Commission for Scheduled Castes.
9	U.P State Safai Karamcharis Commisssion, Lucknow.	9	Kerala State SC/ST Commission, Kerala.
10	Tripura State Commission for Safai Karamcharis, Trlpura.	10	Orissa SC& ST Development Finance co-operative corporation Ltd. Bhuvneshwar.
11.	State level Commission for Safai Karamcharis, Mizoram.	11	State level Commission for Backward Classes Puducherry.
		12	Tamil Nadu State SC/ST Commission.
		13	West Bengal SC, ST & OBC Developmsnt & Finance Corporation.
		14	Arunachal Pradesh - Chief Commissioner (RTi) as State Commissioner for Safai Karamcharis.
		15	Jammu & Kashmir - Commissioner, Municipal Corporation, Srinagar and Commissioner, Municipal Corporation, Jammu.
16	Sikkim State Commission for the Backward Classes (SCBC)	16	Sikkim State Commission for the Backward Classes (SCBC)

578 // True copy //

↳

List of States/UTs those have not informed about constitution of State level Commission for Safai Karamoharis/Designated Agency upto 31.12.2023.

Sl.No.	Name of State/UT
1	Gujarat
2	Jharkhand
3	Manipur
4	Meghalaya
5	Nagaland
6	Telangana
7	Chandigarh
8	Ladakh
9	Lakshadweep

True copy,

S

579